

## Detector and Laser Control Module for bh TCSPC Systems

- Power supply and gain control for bh TCSPC detectors
- Power control for bh BDL-SMN, BDS-SM, and BDS-MM lasers
- Gain control for Hamamatsu R3809U MCP via bh HVM module
- Overload shutdown of detectors
- Control of shutters and ND filter wheels
- Power supply for detector cooling
- Short-circuit protected +12V, +5V and -5V power supply for preamps
- PCI and PCI Express cards
- Control software integrated in bh SPCM TCSPC data acquisition software

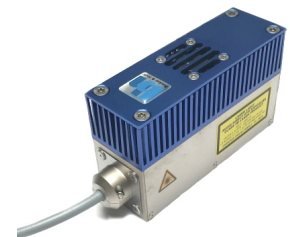

The bh DCC-100 and DCC-100 pcie modules control detectors and lasers in conjunction with the bh TCSPC systems. One DCC-100 provides power supply, gain control, and overload shutdown for two detectors. For cooled PMT modules the DCC also provides the power supply to the thermoelectric coolers. It can be used to operate a wide variety of detectors, including the bh HPM-series hybrid detectors, the PMC-100 and PMC-150, the bh PMCS-150, and the bh PML-16C and PML-16 GaAsP multi-wavelength detectors. The DCC-100 also controls the power of the BDS and BDL series picosecond diode lasers. Moreover, the DCC modules have high-current outputs for controlling shutters, electromagnetic actuators, and ND filter wheel. Due to their versatility the DCC modules are part of almost any bh TCSPC system. The DCC-100 is a PCI module, the DCC-100 PCIe a PCI Express module. Both modules work under Windows 7 and Windows 10.

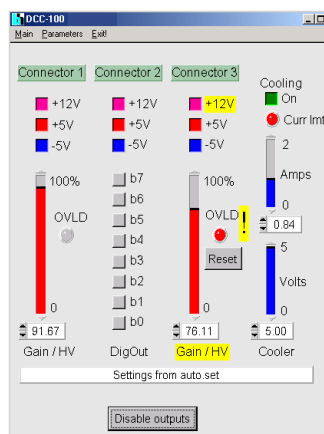
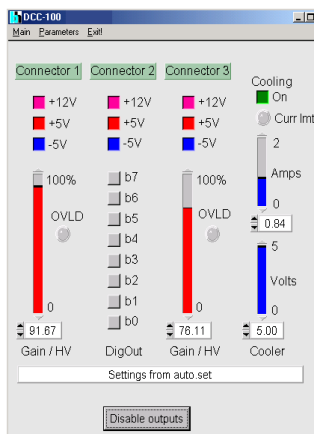

# DCC-100

## Application Information

### Connecting Lasers and Detectors to the DCC-100

#### Simple Fluorescence-Lifetime System

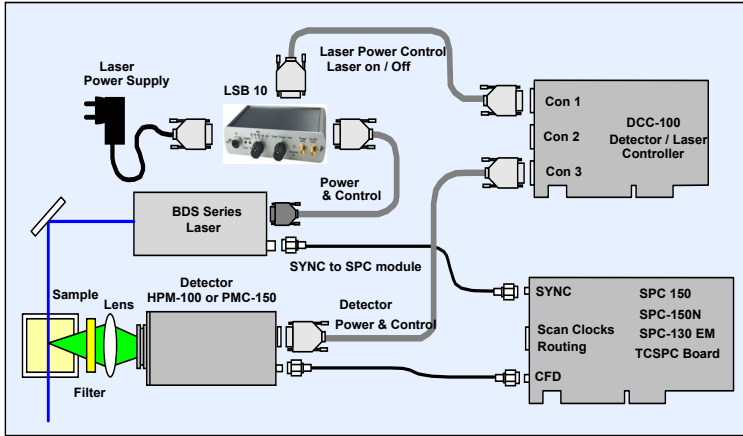

#### FLIM System for Zeiss LSM 880/980NLO

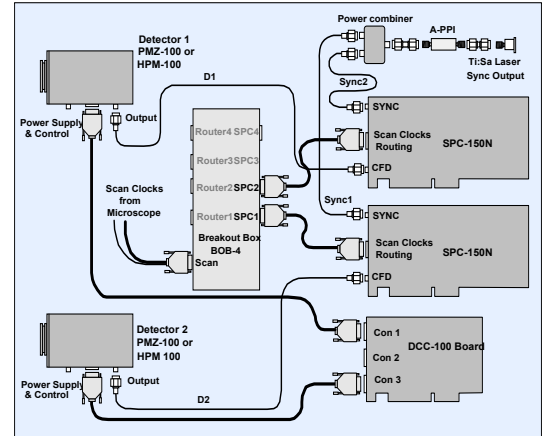

### Setting the Correct Detector Gain

Adjusting the detector gain for PMT modules

Select the CFD Threshold in SPCM to the value recommended for the detector. Send a low-intensity light signal to the detector. Increase the Gain in the DCC panel (left) until you reach a plateau in the count rate. The optimum gain region is marked (middle). If an overload shutdown occurs reduce the light intensity and reset the overload in the DCC panel (right).

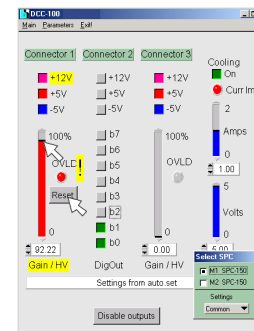
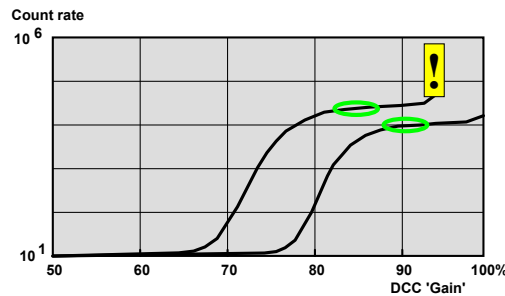
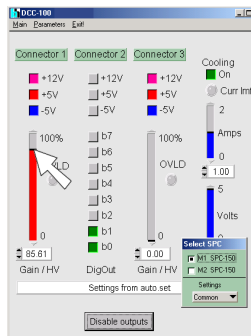

Adjusting the detector gain for HPM series hybrid detectors

Select the CFD Threshold in SPCM to the value recommended for the detector (about -50 mV for HPMs). Send a low-intensity light signal to the detector. Increase the Gain in the DCC panel (left) until you reach a plateau in the count rate. The optimum gain region is marked (middle). Increase the Gain further until an overload shutdown occurs (right). Pull the gain back by about 3%. Reset the overload.

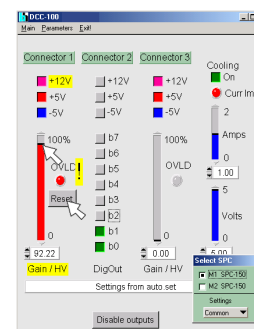
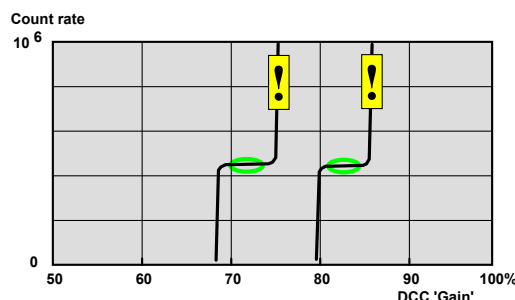
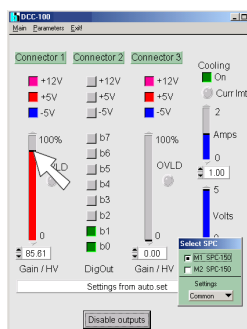



## Configuring the DCC Software Panel

The labels on the 'Gain / HV' sliders and 'DigOut' buttons can be adapted to the functions these elements are performing. You can edit the names after a right mouse click on the labels, see figures below. For the 'DigOut' buttons you can also change the function. It can be a switch, i.e. a mouse click on the button toggles the output state between on and off, or a key, i.e. the output is 'on' only as long as you keep the mouse pointer on the key and hold the mouse key down.

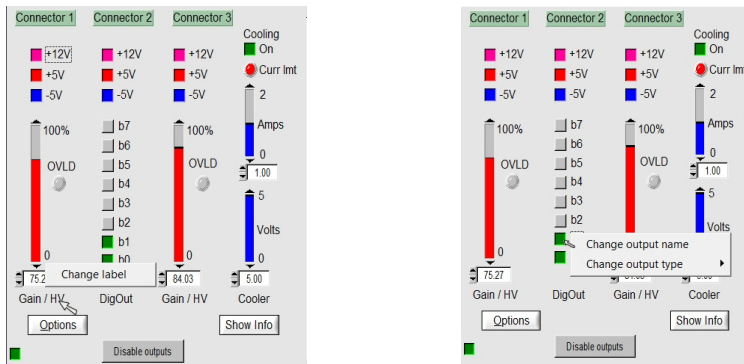

Examples for three different DCC applications are shown in the figures below. The configuration shown left controls two detectors, the configuration in the middle two detectors with shutters. The configuration for controlling two lasers with ND attenuator wheels is shown on the right.

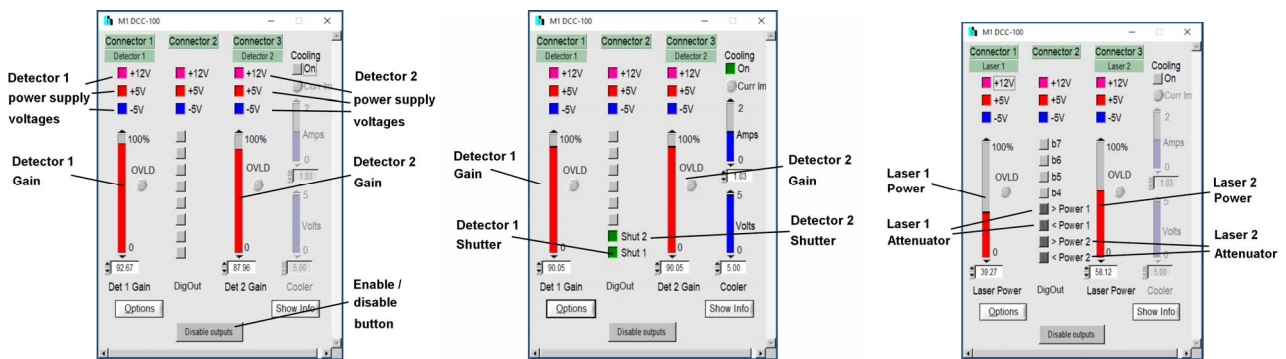

## Connector Pin Assignment

### Connector 1

- 1 +5V out switchable
- 2 Peltier +
- 3 Peltier +
- 4 Peltier +
- 5 GND
- 6 -5V out switchable
- 7 Peltier -
- 8 Peltier -
- 9 Peltier -
- 10 +12V out switchable, ovlD sdwn
- 11 -12V out
- 12 0...+10V HV/gain signal, ovlD sdwn
- 13 0...+0.9V HV/gain signal, ovlD sdwn
- 14 /OVLD1 input
- 15 GND

### Connector 2

- 1 +5V out switchable
- 2 Bit0 open drain out
- 3 Bit1 open drain out
- 4 Bit2 open drain out
- 5 GND
- 6 -5V out switchable
- 7 Bit3 open drain out
- 8 Bit4 open drain out
- 9 Bit5 open drain out
- 10 +12V out switchable
- 11 -12V out
- 12 Bit6 open drain out
- 13 Bit7 open drain out
- 14 NC
- 15 GND

### Connector 3

- 1 +5V out switchable
- 2 Peltier +
- 3 Peltier +
- 4 Peltier +
- 5 GND
- 6 -5V out switchable
- 7 Peltier -
- 8 Peltier -
- 9 Peltier -
- 10 +12V out, switchable, ovlD sdwn
- 11 -12V out
- 12 0...+10V HV/gain control signal, ovlD sdwn
- 13 0...+0.9V HV/gain control signal, ovlD sdwn
- 14 /OVLD3 input
- 15 GND



Technology Leader in Time-Correlated Single Photon Counting  
More than 2500 TCSPC Systems Worldwide

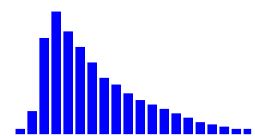



# DCC-100

## Power Supply Outputs (Connectors 1 to 3)

Max. Current at +12 V	100 mA
Short Circuit Current +12 V	50 mA <sup>1)</sup>
Time from /OVLD to disable +12V	10 ms <sup>2)</sup>
Output current in disabled state, +12 V	< 0.5 mA
Max. Current at +5 V	200 mA
Short Circuit Current +5 V	60 mA <sup>1)</sup>
Output current in disabled state, +5 V	< 0.5 mA
Max. Current at -5 V	200 mA
Short Circuit Current -5 V	60 mA <sup>1)</sup>
Output current in disabled state, -5 V	< 0.5 mA
Max. Current at -12 V	Sum 120 mA, single output 60 mA
Short Circuit Current -12 V	No short protection. Don't short longer than 1s

<sup>1)</sup> Foldback Characteristics, don't short several outputs simultaneously for more than 20s

<sup>2)</sup> Connectors 1 and 3 only. 250 Ω load, time from +12V to +6V output voltage.

## Detector Gain Control (Connectors 1 and 3)

Resolution	12 bit
Voltage Range Pin 12	0 to +10 V
Load at Pin 12	min. 1 kΩ
Output Resistance at Pin 12	100 Ω
Voltage Range Pin 13	0 to +0.9 V
Load at Pin 13	min. 1 kΩ
Output Resistance at Pin 13	100 Ω
Output Time Constant	100 ms

## Overload Shutdown

Overload inputs at connector 1 and 3	TTL, active Low, Pull-up resistor 10 kΩ
Overload Reset	By Software and at Power-ON

## High Current Switches (Connector 2)

Typical 'On' Resistance, 25°C	70 mΩ
Max. Switch Current, Single Switch	2 A
Max. Switch Current, Sum of all Switches	5 A <sup>3)</sup>
Max. turn-off Voltage at Switch	20 V
Turn-on and turn-off transition time, Load 10 Ω	100 ns
Disable on /OVLD	configurable by jumper
Disable Transition Time	< 1 us
Time from /OVLD to Disable	< 2 us

<sup>3)</sup> Both GND pins used

## Supply for Thermoelectric Coolers (Connector 3)

Output Voltage	0 to 5 V
Output Current	0 to 2 A
Resolution of Output Voltage and Current	12 bit
Output Resistance	0.4 Ω <sup>4)</sup>
Output Capacitance	300 uF
Output Ripple	< 5 mV

<sup>4)</sup> All pins parallel

## PC Interface

Dimensions	160 mm x 106 mm x 15 mm
Interface / Connector	PCI or PCI Express
Supply Current, +5V, No Load, typ. value	0.6 A
Supply Current, +5V, Maximum Load, typ. value	1.2 A
Supply Current, +12V, No Load, typ. value	0.2 A
Supply Current, +12V, Maximum Load, typ. value	1.6 A

## Related Products

DCU 400 Detector/Laser Controller with USB interface

## International Sales Representatives



US:  
**Boston Electronics Corp**  
 tcspec@boselec.com  
 www.boselec.com



UK:  
**Photonics Solutions PLC**  
 sales@psplc.com  
 www.psplc.com



Japan:  
**Tokyo Instruments Inc.**  
 sales@tokyoinst.co.jp  
 www.tokyoinst.co.jp



China and Hongkong:  
**DynaSense Photonics Co. Ltd.**  
 info@dyna-sense.com  
 www.dyna-sense.com