

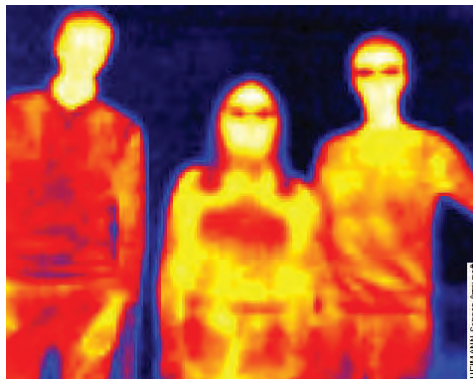

Infrared Detector Arrays

Low Cost Thermal Imaging



HEIMANN
Sensor

www.boselec.com | boselec@boselec.com | shop.boselec.com | 617-566-3821

Infrared (IR) Imaging Arrays

Silicon-based thermopile IR arrays are the most affordable, robust thermal imaging sensors available. Thermopile imaging arrays, from our partner, Heimann Sensor, are more compact, affordable and scalable in production than other infrared imaging technologies. Heimann offers the worldwide first fully monolithic thermopile arrays in TO-8, TO-39 and TO-46 housing.

The sensors are available in a **variety of array formats**, packages **digital or analog output** and with **integrated lenses**. Thus, the sensors are tailored to your FOV requirements, without the need for expensive, bulky external optics. Further, they are **factory calibrated**, and do not need shutter or non-uniformity correction, thus greatly simplifying the design of your sensor system.

These devices are ideal for high volume applications including:

- surveillance,
- home and building control and automation,
- robotics,
- machine vision
- home security
- instrumentation
- fire monitoring
- anywhere compact, affordable thermal imaging is needed

A wide range of array configurations are available:

- 8x8d elements (digital)
- 16x4d elements (digital)
- 16x16d elements (digital)
- 32x32d elements (digital)
- 60x40d elements (digital)
- 80x64d elements (digital)
- 120x84d elements (digital)

Applications Sets and Laser Profilers

Applications Sets are available for quick-start imaging capability, and allow fast implementation of your system design. These are turnkey kits ready to go out of the box. Application Sets include an IR-Camera with integrated optics (or flat window for laser profilers) and an Ethernet or USB interface. A windows-based visualization software is also include to control the cameras.

The sets include:

- IR-Camera (32x32d, 80x64d or 120x84d, digital interface or other formats – see catalog)
- Power Supply
- Tripod
- Cables
- Software

Heimann Sensor - Thermopile imaging arrays - Digital output (I2C, SPI, UDP)

Array	Package	Lens FL (mm)/f#	Lens material	Application Set (Ready to go, just add your PC)	Array only*			Array output
					2	20	200	
8x8	TO-46	2.1/0.8	Si	\$277.00	\$51.40	\$31.60	\$19.00	I2C
16x16	TO-39	1.0/0.85	Si	\$277.00	\$46.80	\$33.70	\$24.10	I2C
		2.1/0.8	Si	\$277.00	\$46.80	\$33.70	\$24.10	I2C
32x32	TO-39	1.6/0.8	Si	\$277.00	\$60.70	\$46.40	\$30.60	I2C
		2.1/0.8	Si	\$277.00	\$57.50	\$44.60	\$29.40	I2C
		4.0/0.7	Ge	\$277.00	\$88.70	\$69.50	\$49.30	I2C
		5.0/0.8	Ge	\$277.00	\$72.10	\$55.20	\$36.90	I2C
80x64	TO-8	3.9/0.8	Ge	\$388.00	\$268.00	\$218.00	\$159.00	SPI
		4.8/0.8	Ge	\$388.00	\$268.00	\$218.00	\$159.00	SPI
		10.0/0.7	Ge	\$388.00	\$268.00	\$218.00	\$159.00	SPI
		10.5/0.95	Ge	\$388.00	\$191.00	\$149.00	\$111.00	SPI
		21.5/0.9	Ge/Si	\$388.00	\$184.00	\$141.00	\$104.00	SPI
		33/1.1	Ge	\$388.00	\$223.00	\$171.00	\$123.00	SPI
80x64			CaF2	\$495.00				UDP
Beam	TO-8	Flat window	BaF2	\$495.00				UDP
Profiler			Ge	\$495.00				UDP

Overview Infrared Thermopile Array Sensors



HTPA Assortment (1/2)

..... variants

Sensor	Xenon	Vacuum	Vacuum+ Umbrella	FOV [°]	default FPS [Hz]	typical Hi, NETD [mK] @ 1Hz@25°C	typical UHi, NETD [mK] @ 1Hz@25°C	NO dual use	interface	TO-header
HTPA8x8d										
HTPA8x8dR1L0.8/0.8F5.0	HIC[Sj]	---	---	47 x 47	37	124	---	X	I2C	TO-46
HTPA8x8dR1L2.1/0.8F5.0	HIC[Sj]	---	---	23 x 23	37	127	---	X	I2C	TO-46
HTPA16x4d										
HTPA16x4R1L2.1	EA	---	---	110 x 25	16	75	---	X	I2C	TO-39
HTPA16x4R1L3.6	EA	---	---	60 x 15	16	125	---	X	I2C	TO-39
HTPA16x4R1L5.5	EA	---	---	35 x 9	16	170	---	X	I2C	TO-39
HTPA16x16d										
HTPA16x16dR2L1.0/0.8F5.0	HIC[Sj]****	---	---	90 x 90	17.5	160*	---	X	I2C	TO-39
HTPA16x16dR2L2.1/0.8F5.0	HIC[Sj]	---	---	45 x 45	17.5	160	---	X	I2C	TO-39
HTPA16x16dR2L5.0/0.8F7.7	HIC	---	---	16 x 16	17.5	155	---	X	I2C	TO-39
HTPA32x32d										
Single Optics										
HTPA32x32dR2L1.6/0.8F5.0	HIC[Sj]	---	---	95 x 95	8.3	370	---	X	I2C	TO-39
HTPA32x32dR2L1.9/0.8	HIC[Ch]	---	---	96 x 96	8.3	173	---	X	I2C	TO-39
HTPA32x32dR2L2.1/0.8F5.0	HIC[Sj]	---	---	90 x 90	8.3	329	---	X	I2C	TO-39
HTPA32x32dR2L5.0/0.8F7.7e	HIC	---	---	33 x 33	8.3	254	---	X	I2C	TO-39
Dual Optics										
HTPA32x32dR2L1.8/0.7	HIC	---	---	93 x 93	8.3	160	---	X	I2C	TO-39
HTPA32x32dR2L4.0/0.7F7.7	HIC	---	---	40 x 40	8.3	140	---	X	I2C	TO-39
HTPA60x40d										
HTPA60x40dR1L1.9/0.8	---	---	TUHC[Ch]	92 x 60***	21.2	---	tbid	X	SPI	TO-39
HTPA60x40dR1L4.0/0.8	---	---	TUHC[Ch]	38 x 25***	21.2	---	tbid	X	SPI	TO-39

Order Example: HTPA32x32dR2L5.0/0.8F7.7eHIC[Sj] (sensor + variant)

Standard parts with shorter delivery time
 Available parts in sample quantities
 — Parts not in assortment / not available
 * estimated NETD
 ** on request
 *** estimated FOV
 **** available from Q1/22

Overview Infrared Thermopile Array Sensors



HTPA Assortment (2/2)

variants

Sensor	Xenon	Vacuum	Vacuum+ Umbrella	FOV [°]	default FPS [Hz]	typical Hi, NETD [mK] @ 1Hz @ 25°C	typical UHi, NETD [mK] @ 1Hz @ 25°C	NO dual use	interface	TO-header
HTPA8x60d										
HTPA8x60dL3.1	---	---	TUHC[Ch]	100x68 ***	tbd	---	tbd	X	SPI	TO-8
HTPA8x60dL7.0/0.8F7.7	---	---	TUHC[Ch]	40x28 ***	tbd	---	tbd	X	SPI	TO-8
HTPA80x64d										
HTPA80x64dR2L3.9/0.8	HIC	UHIC	TUHC	120x90	9	260	87	X	SPI	TO-8
HTPA80x64dR2L4.8/0.8	HIC	UHIC	TUHC	90x70	9	390	80	X	SPI	TO-8
HTPA80x64dR2L10/0.7F7.7	HIC	UHIC	TUHC	41x33	9	233	70	X	SPI	TO-8
HTPA80x64dR2L10.5/0.95F7.7	HIC	UHIC	TUHC	39x31	9	333	115*	X	SPI	TO-8
HTPA80x64dR2L1.5/0.9	HIC[Ge/Si]	UHIC[Ge/Si]	TUHC[Ge/Si]	19x15	9	263	90*	X	SPI	TO-8
HTPA80x64dR2L3.3/1.05	HIC**	UHIC**	TUHC**	12x9	9	279	155*	X	SPI	TO-8
HTPA120x84d										
HTPA120x84dL3.9/0.8	---	---	TUHC	120x77	9	---	170*		SPI	TO-8
HTPA120x84dL4.8/0.8	---	---	TUHC	90x60	9	---	250*		SPI	TO-8
HTPA120x84dL10/0.7F7.7	---	---	TUHC	41x29	9	---	150		SPI	TO-8
HTPA120x84dL3.3/1.05	---	---	TUHC**	12x9	9	---	300*		SPI	TO-8

Standard parts with shorter delivery time

Available parts in sample quantities

--- Parts not in assortment / not available

* estimated NETD

** on request

*** estimated FOV

Order Example: HTPA32x32dR2L5.0/0.85F7.7eHIC[Si](sensor+variant)

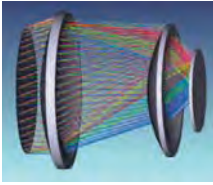

Field of View Calculation



$$FOV = 2 \cdot \arctan\left(\frac{N_{Col/Row} \cdot P}{2 \cdot f}\right)$$

f= focal length of the lens

P=Pitch of the sensitive elements

NCol/Row=Number of elements in Column or Row, depending if the FOV in horizontal or vertical direction should be calculated

Due to spherical aberrations we will provide detailed information concerning field curvature and distortion, if required.

If the application requires different types of coatings, we can also provide these, including LWP and band pass filters.

Heimann Sensor

HTPA series thermopile-based infrared imaging arrays

Minimum recommended working distance			
Array size	Lens		Working distance (mm)
	(Focal length/aperture)	(Field of view)	
8x8	L0.8/0.8	47°x47°	6
	L2.1/0.8	19°x19°	41
16x4	L2.1/0.8	110°x25°	17
	L3.6/0.9	60°x15°	44
	L5.5/1.1	35°x9°	92
16x16	L1.0/0.8	90°x90°	10
	L1.6/0.8	54°x54°	24
	L2.1/0.8	45°x45°	41
	L5.0/0.85	16°x16°	218
32x32	L1.6/0.8	105°x105°	24
	L1.8/0.7	93°x93°	34
	L1.9/0.8	96°x96°	34
	L2.1/0.8	90°x90°	41
	L4.0/0.7	40°x40°	170
	L5.0/0.85	33°x33°	218
80x64	L3.9/0.8	120°x90°	141
	L4.8/0.8	90°x70°	213
	L10/0.7	41°x33°	1,058
	L10.5/0.95	39°x31°	860
	L33/1.05	12°x9°	7,683
120x84	L3.9/0.8	120°x77°	215
	L4.8/0.8	90°x60°	320
	L10.0.7	41°x29°	1,587
	L33/1.05	12°x9°	11,524



HTPA120x84d

Infrared Thermopile Array Sensors for Remote Temperature Measurement and Imaging Applications

The HTPA120x84d is the result of consequent further development and the bigger brother of the 80x64d infrared array sensor. It features a resolution of 120x84 pixel inside the same TO-8 housing with the same mechanical and electrical dimensions as the 80x64d.

Due to the digital SPI interface, only 6 pins are needed. It has a built-in EEPROM to store all calibration data and a 16-bit ADC. The speed can be set internally via the sensor clock and ADC-resolution between 16 Hz (highest resolution) and 28 Hz (lower resolution).

Dimensions

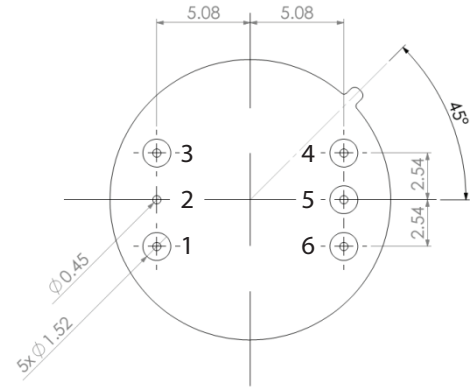

Available Optics

Optic	L3.9	L4.8	L10	L33*
FoV [°]	120x77	90x60	41x29	12x9
Length of cap [mm]	15.4	16.7	28.3	46
Diameter of cap [mm]	20	20	23	37
F-number	0.8	0.8	0.7	1.05

* Only on request



Characteristics

Parameter	Value	Tolerance	Unit
Supply voltage (DC)	3.3	+0.3/-0.0	V
Current consumption	30	+/-5.0	mA
Clock frequency (Sensor)	10	± 5	MHz
Ambient temperature range	-20 to 85		°C
Object temperature range	-20 to >1000		°C
Framerate (full frame)	2 to 50		Hz
Framerate (sixth part of array)	12 to 300		Hz
NETD (best optics)	150		mK@1Hz

Pin Configuration (SPI)

Pin	Function
1	3.3 V Supply
2	Ground
3	EE_Enable
4	MISO
5	MOSI
6	SCLK

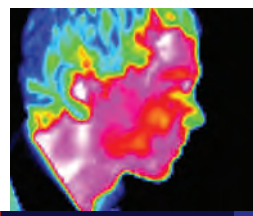

Picture of a face profile

HTPA80x64d

Infrared Thermopile Array Sensors for Remote Temperature Measurement and Imaging Applications

The HTPA80x64d is the bigger brother of the 32x32d infrared array sensor with a resolution of 80x64 pixel inside a TO8 housing.

Due to the digital SPI interface only 6 pins are needed. It has a built-in EEPROM to store all calibration data and a 16-bit ADC. The speed can be set internally via the sensor clock and ADC-resolution between 20 Hz (highest resolution) and 41 Hz (lower resolution).

Dimensions

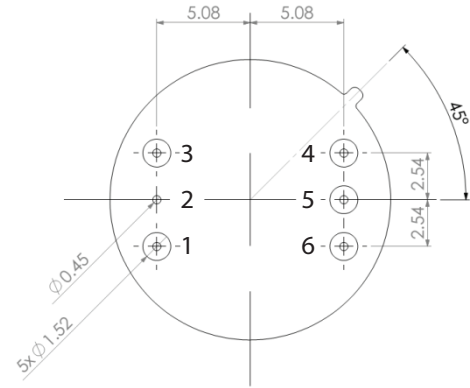

Available Optics

Optic	L3.9	L4.8	L10	L10.5	L21.5	L33*
FoV [°]	120x90	90x70	41x33	39x31	19x15	12x9
Length of cap [mm]	12.6	14.6	25.7	24.1	35.8	46
Diameter of cap [mm]	20	20	23	23	28	37
F-number	0.8	0.8	0.7	0.95	0.9	1.05

* Only on request



Characteristics

Parameter	Value	Tolerance	Unit
Supply voltage (DC)	3.3	+0.3/-0.0	V
Current consumption	26	+/-5.0	mA
Clock frequency (Sensor)	5	± 3	MHz
Ambient temperature range	-20 to 85		°C
Object temperature range	-20 to >1000		°C
Framerate (full frame)	1 to 41		Hz
Framerate (quarter frame)	4 to 164		Hz
NETD (best optics)	230/70*		mK@1Hz

*: NETD valid for UHi version

Pin Configuration (SPI)

Pin	Function
1	3.3 V Supply
2	Ground
3	EE_Enable
4	MISO
5	MOSI
6	SCLK

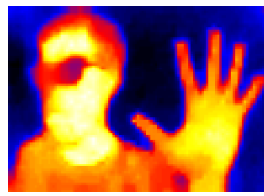

HTPA60x40d

Infrared Thermopile Array Sensors for Remote Temperature Measurement and Imaging Applications

The HTPA60x40d is a complete new generation of thermopile array and filling the gap between 32x32 and 80x64.

It comes with a wafer-level vacuum package and 45 μm pixel pitch. The HTPA60x40d sets new standards for thermopile array sensitivity, size and speed.

The digital SPI interface with only 6 pins gives framerates of 21 Hz at full 16 bit ADC resolution, while the sensor is not subject to dual use regulations.

Dimensions

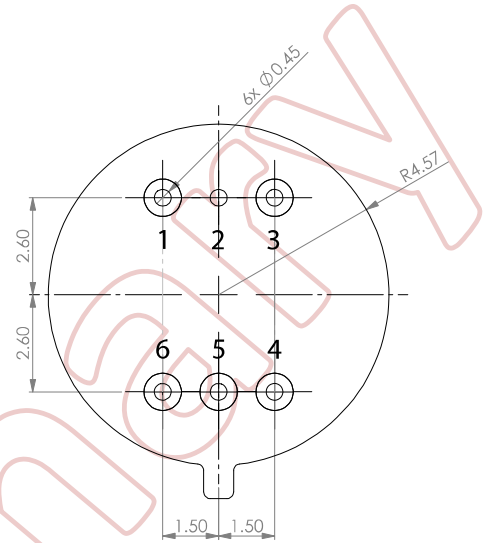

Available Optics

Optic	L1.9	L4.0
FoV [°]	92x60	38x25
Length of caps [mm]	tbd	tbd
Diameter of cap [mm]	tbd	tbd
F-number	0.8	0.8



Characteristics

Parameter	Value	Tolerance	Unit
Supply voltage (DC)	3.3	+0.3/-0.0	V
Current consumption	4.5	+/-tbd	mA
Clock frequency (Sensor)	2	+3.5/-1.5	MHz
Ambient temperature range	-20 to 85		°C
Object temperature range	-20 to >1000		°C
Framerate (full frame)	5 to 47		Hz
Framerate (fifth part of array)	25 to 235		Hz
NETD (estimated)	<90		mK@1Hz

Pin Configuration (SPI)

Pin	Function
1	3.3 V Supply
2	Ground
3	EE_Enable
4	MISO
5	MOSI
6	SCLK

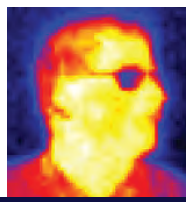

Picture of a face profile,
taken with the HTPA32x32d L5.0

HTPA32x32d

Infrared Thermopile Array Sensors for Remote Temperature Measurement and Imaging Applications

The HTPA32x32d is an infrared array sensor with a resolution of 32x32 pixel in a TO39 housing.

Due to the digital I²C interface only 4 pins are needed. It has a built-in EEPROM to store all calibration data and a 16-bit ADC. The speed can be set internally via the sensor clock and ADC-resolution between 15 Hz (highest resolution) and 27 Hz (lower resolution).

Available Optics

Optic	L1.6 [Si]	L1.8 [Ge]	L2.1 [Si]	L4.0 [Ge]*	L5.0 [Ge]*	L5.0 [Ge]**
FoV [°]	105	93	90	40	33	33
Length of cap [mm]	4.3	7.3	4.45	16.3	7.63	10.41
F-number	0.8	0.7	0.8	0.7	0.85	0.85

*: Ge optics ensure the best performance thus command a higher price.
**: Same optics but an external aperture for better performance is added.
Other optics are available upon request.

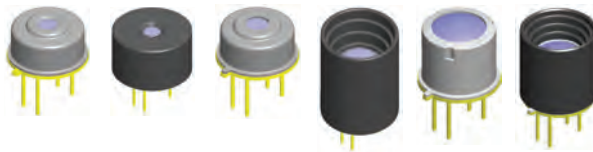

Pin Configuration*

Pin	Function
1	Clock (I ² C)
2	3.3 V Supply
3	Ground
4	SDA (I ² C)

* HTPA32x32L2.1, TO39 housing (other optics are available)



Dimensions

HTPA32x32L2.1, TO39 housing

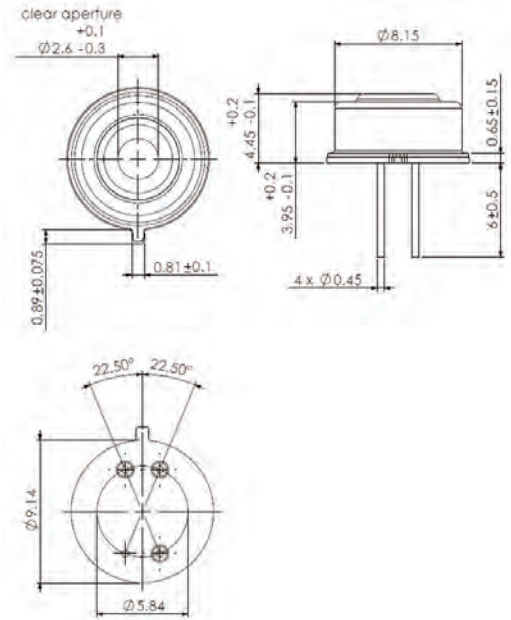

Characteristics

Parameter	Value	Tolerance	Unit
Supply voltage (DC)	3.3	+0.3/-0.0	V
Current consumption	5.5	± 1.0	mA
Clock frequency (Sensor)	5	± 3	MHz
Ambient temperature range	-20 to 85		°C
Object temperature range	-20 to >1000		°C
Framerate (full frame)	2 to 27		Hz
Framerate (quarter frame)	8 to 110		Hz
NETD (best optics)	140		mK@1Hz

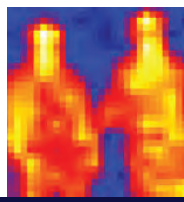

Picture of 2 persons

HTPA16x16d

Infrared Thermopile Array Sensors for Remote Temperature Measurement and Imaging Applications

The HTPA16x16d is an infrared array sensor with a resolution of 16x16 pixel in a TO39 housing.

Due to the digital I²C interface only 4 pins are needed. It has a built in EEPROM to store all calibration data and a 16-bit ADC. The speed can be set internally via the sensor clock and ADC-resolution between 40 Hz (highest resolution) and 70 Hz (lower resolution).

Available Optics

Optic	L1.6 [Si]	L2.1 [Si]
FoV [°]	54	45
Length of cap [mm]	4.3	4.45
F-number	0.8	0.8

Other optics are available upon request.



Pin Configuration

Pin	Function
1	Clock (I ² C)
2	3.3 V Supply
3	Ground
4	SDA (I ² C)



Dimensions

HTPA16x16L2.1, TO39 housing

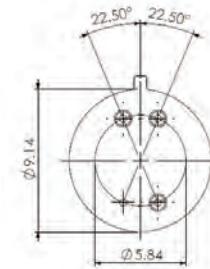
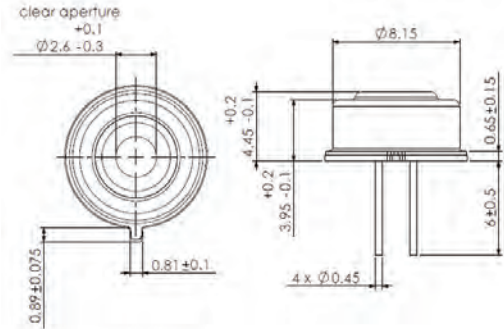

Characteristics

Parameter	Value	Tolerance	Unit
Supply voltage (DC)	3.3	+ 0.3/-0.0	V
Current consumption	3.5	± 1.0	mA
Clock frequency (Sensor)	5	± 3	MHz
Ambient temperature range	-20 to 85		°C
Object temperature range	-20 to >1000		°C
Framerate (full frame)	2 to 70		Hz
Framerate (half frame)	8 to 140		Hz
NETD	160		mK@1Hz

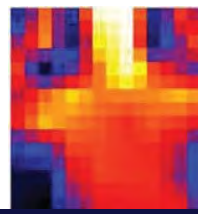

Picture of a person with raised arms

HTPA8x8d

Infrared Thermopile Array Sensors for Remote Temperature Measurement and Imaging Applications

The HTPA8x8d is the world smallest infrared array sensor with a resolution of 8x8 Pixel inside a TO-46 housing.

Due to the digital I²C interface only 4 pins are needed. It has a built-in EEPROM to store all calibration data and a 16-bit ADC. The speed can be set internally via the sensor clock and ADC-resolution between 89 Hz (highest resolution) and 160 Hz (lower resolution).

Available Optics

Optics	L0.8 (TO-46)	L2.1 (TO-46)
FoV [°]	47	19

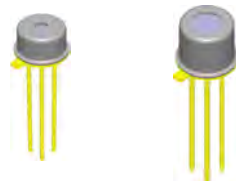

Pin Configuration

Pin	Function
1	SDA (I ² C)
2	Clock (I ² C)
3	3.3 V Supply
4	Ground

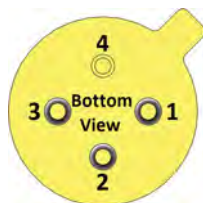

Dimensions

HTPA8x8L2.1, TO-46 housing

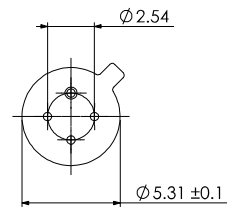
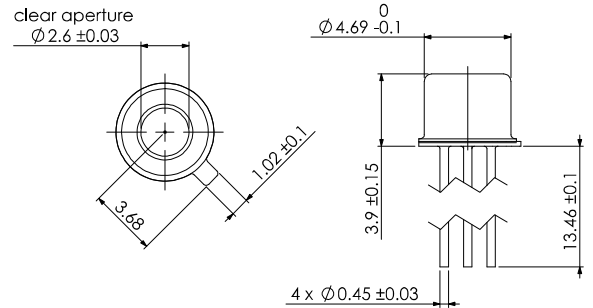

Characteristics

Parameter	Value	Tolerance	Unit
Supply voltage (DC)	3.3	+ 0.3/-0.0	V
Current consumption	1.8	± 0.5	mA
Clock frequency (Sensor)	5	± 3	MHz
Ambient temperature range	-20 to 85		°C
Object temperature range	-20 to >1000		°C
Framerate	7 to 160		Hz
NETD	ca. 115		mK@1Hz

Quick Start Application Set

Read-out Circuit for Instantaneous Sensor Evaluation

For thermal imaging and easy evaluation of our arrays, we designed an application set in a modular metal housing for better handling.

The modules field of view depends on the built-in lens and can be varied on demand. The object temperature range depends on the array type and lens.

For every array type we also provide a matching application set in our portfolio, which allows full sensor control. The application set processes the data and communicates via Ethernet/UDP to a PC. On PC side, the data stream can be visualized and logged with a Graphical User Interface. The given software allows the user to instantly start with sensor evaluation, measurements and testing.

Applications

- Person detection
- Fire detection
- Hotspot detection
- Energy management
- Security cameras
- Industrial process control
- Air condition control
- Position detection

Benefits

- Low-cost TO8/TO39/TO46 housing
- Resolutions 8x8d/ 16x16d/ 32x32d/ 80x64d/ 84x60d/ 120x84d available
- Low power consumption
- Short time constant
- High sensitivity of the system
- No need for shutter and thermal stabilization

Features

- Communications via UDP (Ethernet)
- False color images with auto scaling
- Selectable frame rate
- Data log mode
- Contrast adjustment
- Interpolation
- Temperature display
- Several lenses for different fields of view

Included in Delivery

- Array module
- Interface cable
- USB cable for power supply
- Tripod
- Graphical User Interface (GUI) for visualization

Module Dimensions

- Diameter 28 mm; length approx. 55 mm (length depends on chosen lens)

Setup



Thermal Imaging Pictures

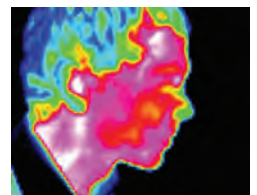

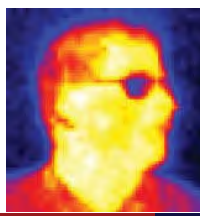

Picture of a face profile,
taken with the HTPA32x32d L5.0

HTPAd USB application set

Plug and play evaluation of Heimann Sensor thermopile arrays

Our HTPAd USB application set is a complete open source plug and play board, which can be used to evaluate all the Heimann Sensor thermopile arrays of the HTPAd family.

It can be instantaneously connected to our graphical user interface for visualization ArraySoft v.2, which allows you to determine the sensor performance on the spot. Compared to our UDP application sets, no basic network knowledge is needed.

Source code and circuitry

The source code was generated by utilizing Microchips MPLAB Harmony for the USB connectivity. The main part of the source is written in a way that allows to use the same functions for every array type. The microcontroller used for the application set is a controller from the PIC32MZ family. For reprogramming of the board (not needed for evaluation purposes) a programmer like PICKit4 is needed. Also, the circuitry of the board is provided.

Visualization and evaluation

The application set can be immediately connected via USB to our visualization tool ArraySoft v2 (windows platform), which allows to visualize the data, create own color schemes, stream the data into txt- and avi files, connect up to 10 recipients, add filtering such as IIR, FIR and median, and has even an alarm feature, which determines which pixel exceed a given temperature. The saved data in txt files can be used i.e. for later evaluations in MATLAB, Excel, etc.

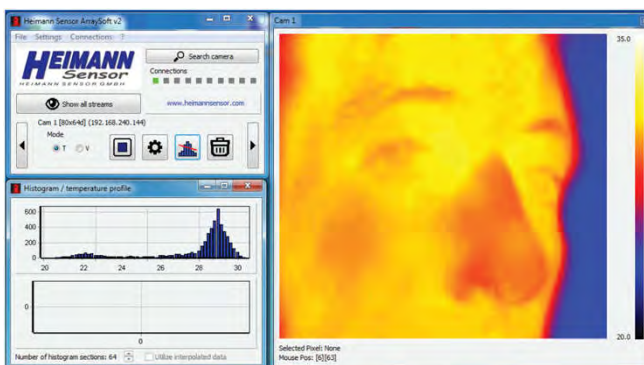

Appearance

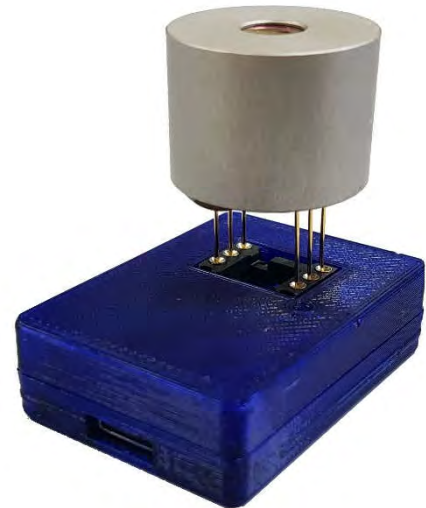

Scope of delivery

- Application set, prepared for the chosen sensor:
 - Soldered socket for given sensor type
 - Flashed with associated code for given sensor type
- USB cable (Type A to micro B)
- Schematic
- Source code
- Heimann Sensor ArraySoft v2



Picture of a face profile,
taken with the HTPA32x32d L5.0

HTPAd Application Shield

Arduino based software development kit (SDK)

This Application Shield can be used with an Arduino or STM32 Nucleo board. It is designed to facilitate the access to our thermopile arrays and provides a quick way to receive the sensor's thermal image.

We provide the complete C++ code as open source software. It includes all required steps from reading the EEPROM to the calculation of the thermal image. The code can be viewed and modified via the Arduino IDE.

The PCB is designed as an Arduino extension and supports the boards Arduino Due and STM32F446RE Nucleo.

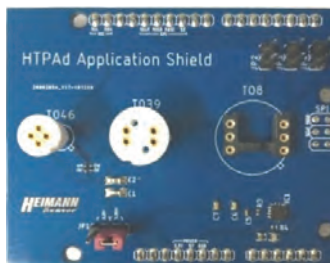

Supported Sensor Types

	TO46	TO39	TO8
I2C	8x8	8x8d 16x16d 32x32d	/
SPI	/	/	80x64d 120x84d*

You can choose between two modes: Ethernet mode and Serial mode. The following table shows which modes are available for each sensor:

Array Size	8x8	16x16	32x32	80x64	120x84*
Ethernet Mode	x	x	x		
Serial Mode	x	x	x	x	x

* Only for STM32F446 Nucleo-64

Required Hard- & Software

Package Content:

- Application Shield
- Sensor of choice
- GUI „Heimann Sensor ArraySoft v2“
- User manual

Additional Requirements:

- Microcontroller platform; the PCB was created and tested for: Arduino Due + STM32F446RE Nucleo-64
- W5500 Ethernet Shield when utilizing Ethernet mode
- USB and Ethernet cable

Serial Mode

This mode prints all results on the serial monitor of the Arduino IDE. Here, the content of the EEPROM and the sensor voltages can be visualized. All that is required is an Arduino Due or STM32F446RE Nucleo board. The serial mode only reads new data upon request to show which calculation steps are required and in which order.

Benefits:

- Shows EEPROM content in hexadecimal or associated data type (float, short, long, ...)
- Prints results after each calculation step



Ethernet Mode

In Ethernet mode, an I2C sensor can be connected to the Heimann Sensor GUI for continuous streaming. The sample code establishes a connection via DHCP or it is possible to use a local network card. An Arduino Ethernet Shield and an Arduino Due or STM32F446RE Nucleo board are required. In the GUI, it is possible to stream the sensor images in temperature or voltage mode. Also, user settings like clock, ADC resolution and the emissivity factor can be altered.

Benefits:

- False color visualization of images
- Continuous streaming
- Switch between temperature and voltage mode
- Record/replay
- Change of user settings

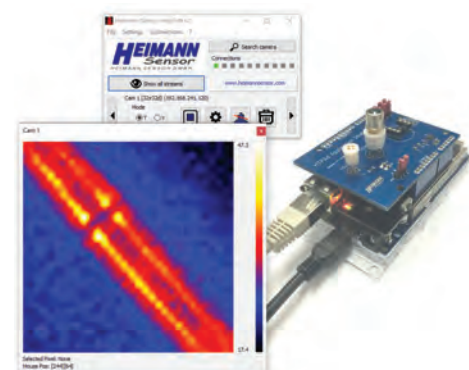

HTPAd Application Shield (WiFi) Arduino based WiFi software development kit (SDK)

This Application Shield is designed to facilitate the access to our thermopile arrays for the fast way to get a thermal image stream from the sensors.

It can be used with an ESP32 development board and thus offers WiFi connectivity to our ArraySoft v2 GUI. This allows the highest degree of flexibility to evaluate the sensors for various applications.



The full code is provided and completely open source. It includes all required steps from reading the EEPROM to the calculation of the thermal image.

The C++ code can be viewed and modified via the Arduino IDE. The PCB is designed as an ESP32-DevKitC-32D extension.

Supported Sensor Types

	TO-46	TO-39	TO-8
I2C	8x8d	16x16d 32x32d	
SPI	/	60x40d	80x64d 84x60d 120x84d

The source code includes two ways to interact with the sensor:

- via **WiFi** you can stream thermal images in our GUI
- via the **serial monitor** you can observe the sensor data as text output

Both modes are contained in the same code and you can activate one or both by activate the matching define.

Required Hard- & Software

What you get:

- HTPAd Application Shield
- GUI „Heimann Sensor ArraySoft v2“
- User manual
- Access to ALL supplementary data for development

What you need additionally:

- ESP32 development board: ESP32-DeckitC-32D
- Arduino IDE
- USB micro-B cable (power supply & serial monitor)

Serial Monitor

This mode prints all results in the serial monitor of the Arduino IDE. Here the EEPROM/Flash content and sensor voltages can be visualized. It's easy to interact with the sensor by sending the characters depending on the menu function you want.

Benefits:

- Show EEPROM/Flash content in hexadecimal or associated data type (float, short, long, ...)
- Print results after each calculation step
- Understand the calculation from raw pixel voltages to the final calibrated thermal image

```

Application Shield v2.0           //_eimann
for ESP32-DevKitC-32D           //_sensor

You can choose one of these options by sending the
character

read SENSOR values:
a... final array temperatures (in deci Kelvin)
b... show all raw values (in digits)
c... show all calculation steps
read EEPROM values:
d... whole eeprom content (in hexadecimal)
e... Header values
f... VddCompGrad
g... VddCompOff
h... ThGrad
i... ThOff
j... PixC (scaled)
write/change EEPROM values:
k... increase emissivity by 1
l... decrease emissivity by 1

ver2.0 (dp)
    
```

WiFi

Operating in WiFi-mode you can connect your thermopile with the Heimann Sensor GUI to stream continuously. With the GUI streaming the sensor images in temperature or voltage mode is possible. At the same time you can manipulate sensor settings, like clock, ADC resolution and emissivity factor and use all advanced features of our GUI.

Benefits:

- False color visualization and post-processing of thermal images
- Continuous streaming
- Switching between temperature and voltage mode
- Record/replay of thermal images and videos
- Change sensor settings

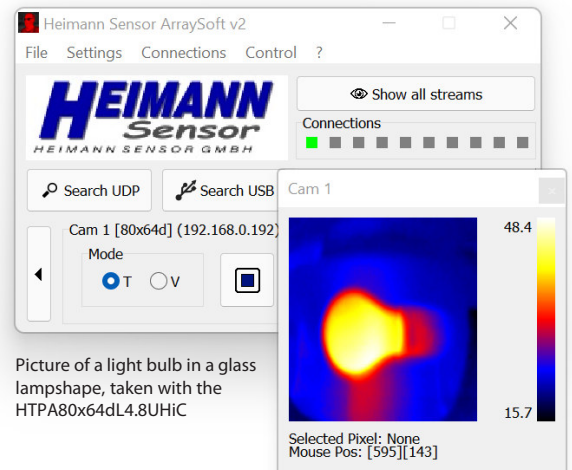



Picture of a face profile

Heimann Sensor ArraySoft v2

Graphical User Interface for HTPA Application Sets

The HTPA Application Set comes with our new comprehensive Graphical User Interface (GUI) "ArraySoft v2", which provides a lot of features and is constantly updated.

It can be used with our digital HTPA Application Sets and enables instant visualization of your measurement data and a quick start for feasibility studies. Other applications are possible, too.

Features

- Many diverse and self designable color scales
- Auto and manual scaling (9 scaling modes)
- Temperature and voltage mode
- Data streaming into files
- AVI export
- Interpolation mode (up to 8x, bicubic/bilinear)
- Complete control of the device
- Multiple, sensor-type independent devices can be controlled
- The data stream of 10 devices can be displayed at the same time
- Histogram
- Selectable temperature or voltage profile
- Filter features: IIR, FIR, Median, adaptive averaging, averaging
- Minimum and Maximum Temperature / Voltage info
- Suitable for all digital HTPA types (8x8d to 120x84d)
- Frames per second indicator
- Alignment for offset corrected frames
- Temperatures in Kelvin, degree Fahrenheit or degree Celsius
- IR-Frame can be mirrored in both axis
- Single Pixel information accessible
- Temperature calculation based on object emissivity
- Screenshot ability (JPG or ASCII data)
- Make your own "thermal movie"
- Time lapse option for videos
- Alarm feature

Instant Visualization

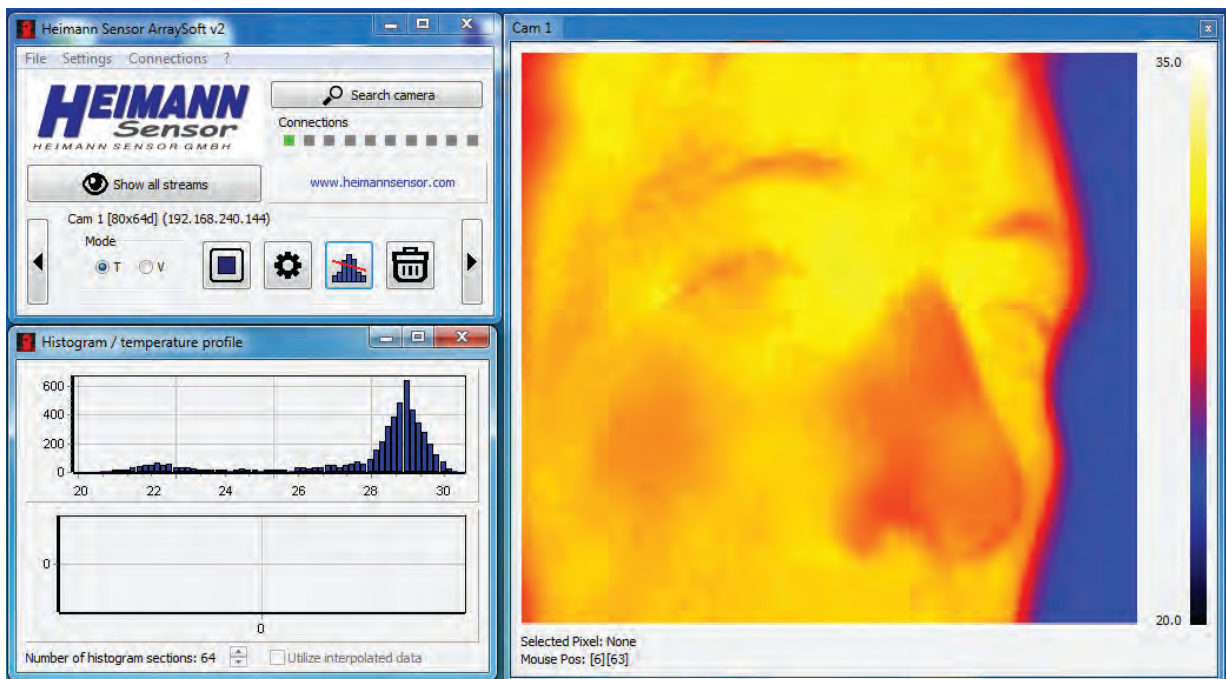

Thermal Imaging Basics

To generate a thermal image, many individual thermopile pixels are arranged in a two-dimensional array. Starting with low resolution of 8x8 and 16x16 pixels, we also provide thermopile arrays with 32x32, 80x64 and 120x84 pixels. This allows our customers to generate thermal images with different spatial resolution for different applications. One of the main fields of interest of our customers include person detection in automation and security applications. Another area is hot spot detection, which includes a wide field of applications from engineering to fire suppression to industrial safety up to consumer goods.

Although the basic principles of non-contact infrared temperature sensing and infrared thermal imaging are the same, we want to offer a few additional basics of thermal imaging as well. This includes a brief overview of the most important basics, which are essentially the same for infrared thermal imaging as for normal visible light cameras. In addition, we provide helpful hints about the most important characteristics that should be considered for spatial temperature measurements.

Infrared Optical Basics

An infrared (IR) optical system can be described by the same parameters that apply for the visible spectrum. The main difference apart from the wavelength, is the material of the lenses. For IR optics usually Germanium (Ge), Silicon (Si), Zinc Sulfide or Chalcogenide glass is used, since these materials show good transparency in the relevant IR spectrum, while ordinary glass is NOT transparent in the thermal infrared spectrum. The most common ones are Ge and Si, where Ge shows a better transparency but at a higher price. Special optical coatings can further improve the transparency, but of course this is also related to a higher price.

Relationship between f-number and Optical Performance

The two main parameters to describe the optical system are the focal length and the f-number. The focal length f in combination with the dimensions of the focal plane area (FPA) determines the field of view (FOV) of the camera. The f-number (N) is the ratio of the focal length to the lens aperture, essentially the diameter of the entrance pupil D . Since it is defined as $N=f/D$ the f-number gets smaller the larger the entrance aperture gets.

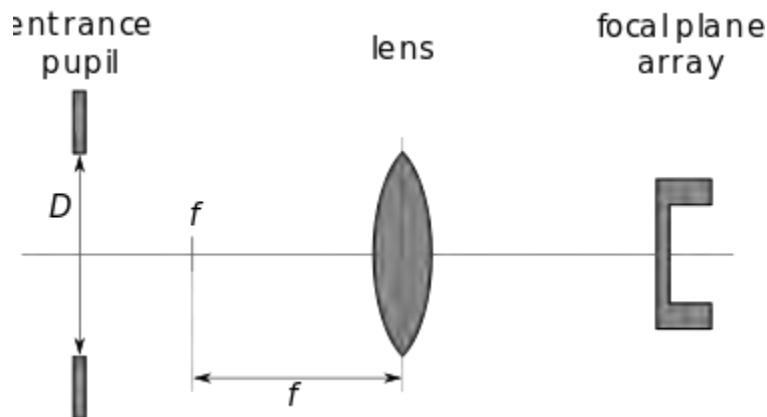

In general, a smaller f-number corresponds to more radiation that can reach the sensitive matrix of the FPA. More radiation will result in a better signal to noise ratio (SNR). Because a low f-number requires a lens system with larger diameter, it also requires more material, and tighter manufacturing tolerances. Better performance is therefore only achievable at a higher price.

Furthermore, the f-number also has an influence on the dynamic range (temperature measurement range) of the optical system. The larger the aperture and the smaller the f-number, the more radiation will be detected by the IR sensitive pixel at a given object temperature. This will reduce the maximum temperature that can be detected, since the signal processing in our FPAs has a fixed gain which cannot be adjusted for different optics. For the analog-digital conversion this means that at a certain level of target radiation a maximum digital output value is produced. If the sensor receives a higher radiation due to smaller f-number, the output will still be the maximum digital value, so the measurement range is truncated, and the sensor is said to be saturated at those pixel locations.

To expand the dynamic range without saturation, optical filters can be used to attenuate parts of the IR spectrum in order to reduce the amount of radiation at the sensor. The usage of small f-number and carefully selected optical filter allows good SNRs for lower object temperatures as well as increased measurement range.

Spatial Temperature Measurements

Before we look at temperature measurements we have to learn about the concept of spatial resolution of optical systems.

Spatial Resolution

If you want to take a thermal image of a scene or object, the three main parameters that determine the spatial resolution are the pixel pitch of the sensor array and the combination of FOV and distance between sensor and object. To get a better understanding of this relation, please refer to the following image:

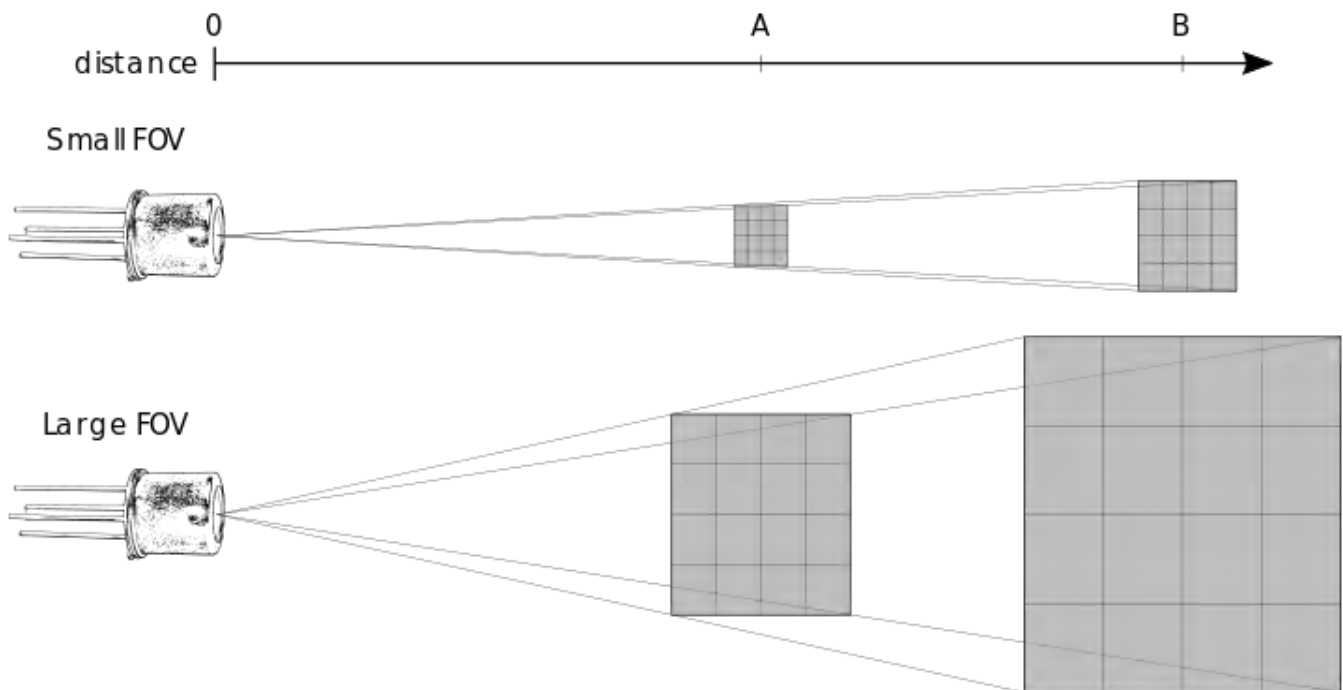

Imagine the FPA is projected through the lens optics onto a distant screen. The FOV determines the projected size of the FPA depending on the distance to the sensor. For the same distance (A resp. B) and same pixel pitch of the FPA a large FOV will result in a larger image with also larger individual pixels than a small FOV. So for greater distances the small FOV optics will have a higher spatial resolution, but of course they also show a smaller part of the scene. If you want to get the same spatial resolution with a large FOV you have two options. One is to reduce the measurement distance (from B to A). Another option is to increase the number of pixels. For the same FPA size this means reducing the pixel pitch. Please note that increasing the number of pixels and keeping the pixel pitch the same results in a larger FPA size which in turn gives a larger FOV.

Determine the Spatial Temperature

Regarding spatial temperature measurements the aforementioned relationships are important to keep in mind.

To determine the temperature of a specific feature or detail in your thermal image, this feature or detail has to illuminate at least one complete pixel. If this is not the case, the pixel will detect a mixed temperature of the object and the adjacent background. The following image will help to make things clear:

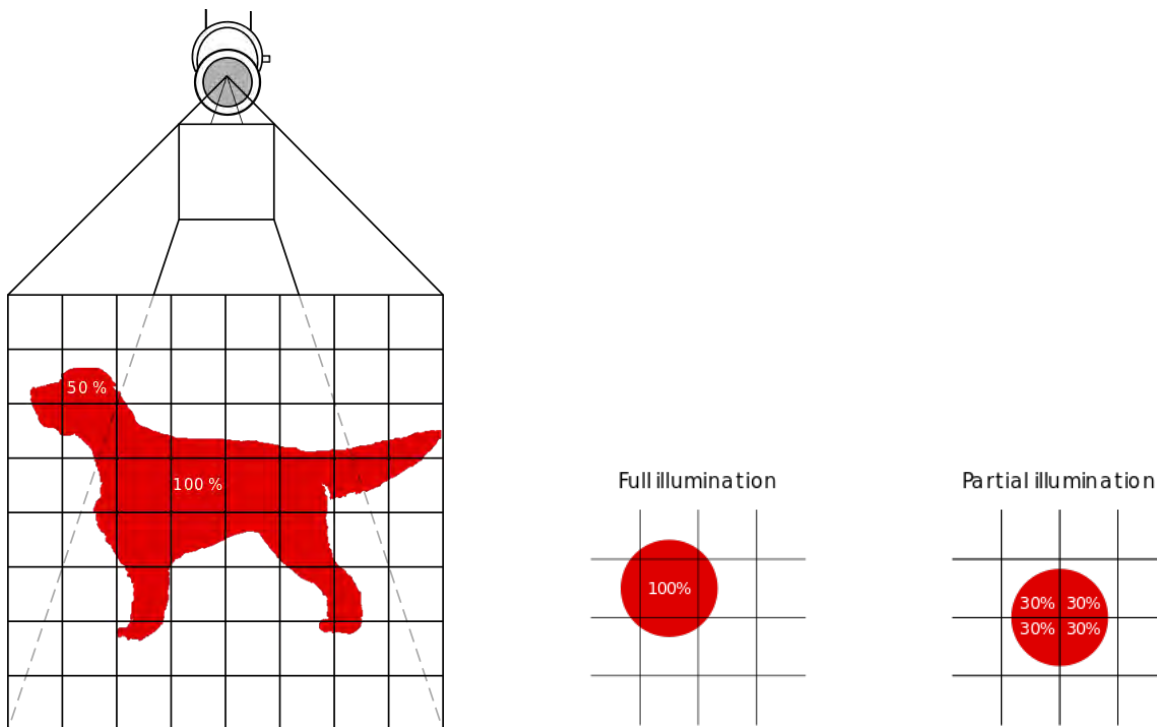

There are two pixels, where the filling factor of the dog versus the background is shown. For the 100% pixel in the middle the camera will detect the temperature of the specific part of the dog. But for the 50% filled pixel at the dog's head the camera will measure the superposition of the dog's head temperature and the background.

In example: If the dog's head temperature is 30°C and the background is 20°C, the camera will detect 25°C as the dog's head temperature.

This problem occurs especially for small objects and features. Even if the object is larger than one pixel the position of the object can have a strong influence on the temperature reading of the sensor. You can see this from the image on the right above.

A shift or movement of small objects can result in significant changes of the temperature readings and cannot be reliably detected. Thus, to determine the correct temperature of an object or feature more than one pixel should be illuminated by the smallest feature that should reliably be detected. It follows that for large target distances or small object sizes you should consider a smaller FOV or a sensor with more pixels.

How to Determine the FOV of your Camera

The ray law can be used to coarsely determine the FOV of the camera:

$$\text{FOV} = 2 \cdot \arctan\left(\frac{P \cdot n}{2 \cdot f}\right)$$

P equals the pixel pitch, n the number of elements in the corresponding direction. This means the FOV can vary in x- and y-direction if the number of elements is not equal in both directions.

To give an example: An 80x64 thermopile array has a pixel pitch of 90µm. Combined with a 17mm focal length optics the FOV will result in 24° x 20°:

$$\text{FOV} = 2 \cdot \arctan\left(\frac{90 \cdot 10^{-6} \text{ m} \cdot 80}{2 \cdot 0.017 \text{ m}}\right) = 23.9^\circ$$

Note, that this formula does not work well for wide FOV optics, since the aberrations of the system are not considered. To determine if an image is large enough for a filling factor of 100% the ray law can also be used. The image size I can be easily calculated by:

$$I = \left(\frac{O \cdot f}{d}\right)$$

where O is the object size, f the focal length and d the distance of the object. The image size divided by the pixel pitch results in the number of pixels illuminated. In example: A human with a shoulder width of 50 cm is 2 meters distant from an HTPA32x32 L5.0. Therefore, f = 0.005 m, O = 0.5m and d = 2m. This results in an image size of I = 1,25e-3 m. With a pixel pitch of 90 µm we get a total of 13.9 pixels illuminated.

Person Detection – Application Note

Intrusion Detection, the automated sensing of a new person or animal into a surveilled area, is one of the main applications of low-resolution thermopile arrays like Heimann Sensor's 32x32 or 80x64 array. It is used for safety and security as well as for making life easier and more comfortable. Examples are smart buildings with functions like smart HVAC control and smart lighting for energy savings. The same system can be used as a security alarm. Other functions include wellness checks of invalids and older people living alone, fire prevention and elevated body temperature detection.

The advantages of low-resolution thermopile arrays for these applications are:

- No privacy issues
- Independent illumination (day/night)
- Not affected by smoke in case of fire or while cooking
- Detection of stationary people (e.g., while sitting/sleeping)
- Low-cost

So let us have a closer look into some specific applications of person and presence detection. We will give a brief overview of some possible applications and discuss the potential benefits of using infrared thermopile arrays.

Intelligent HVAC Control

Intelligent or smart HVAC control is one important application for low-cost infrared arrays like our 32x32 thermopile array. The sensor can detect the occupancy of a room. The number of people can be obtained from the thermal sensor. This data is then used to calculate the required heating and cooling with respect to the number of people, desired room temperature and outside temperature. If there are many people in a room, extra heating in the winter might not be necessary. On the other hand, on a hot summer day, the cooling level should probably be increased. In contrast to normal room thermostats, an intelligent system can anticipate the required heating and cooling. This will result in less overshoot in contrast to a conventional room thermometer which reacts more slowly to room temperature variations resulting in longer time constants. The usage of thermopile arrays for smart HVAC control can drastically reduce the energy consumption of a building.

In addition to energy savings, the level of comfort can also be increased. As the location of all people in a room can be obtained from the infrared array, the direction of the air conditioner ventilation can be controlled in such a way that no one is in the draught. The further increase the comfort, the intelligent HVAC can be combined with an air quality monitoring system for CO₂, which can be realized with single or dual thermopile sensors and sensor modules.

To have an overview of the room, choose a sensor with large field of view of 90 degree or more. The required spatial resolution of the sensor depends on the room's size and height. For most rooms, the 32x32 thermopile array is sufficient, while in large rooms with high ceilings as they can be found in many public buildings, the higher resolution 80x64 array is the better choice.

People Counting

People counting is an important task as knowing the exact number of people in a location can be of great benefit. This applies to shopping malls or shopping centers. Counting people at the entrance and exit to determine the times with high and low demand allows staff level allocation. Mounting of several sensors to

overview a complete store allows tracking individual people. In combination with data analysis, this can give valuable insights in customer behavior and how to run a store effectively. The same is true for public transportation like trains. Counting the entering and exiting people will help to optimize the capacity needed. This can have significant impact and can save cost on personnel and fuel.

Another application is people counting at the entrance of office buildings to know how many people are inside. In case of a fire, this could help to check whether everyone got out, which helps the firefighters to save lives. If mounted on the ceilings of offices, the sensors may also help to prevent fires and detect them at a very early stage. This is discussed in more detail on our page about hot spot detection.

Elderly People Monitoring

People all around the world are living longer. Especially in western societies, many people prefer to live in their own home as long as possible instead of a nursing home or assisted living. This creates a dilemma for the caregivers and relatives. On one hand the caregivers and relatives want to be sure that everything is fine and on the other hand they cannot be present at all times.

One emerging solution are elderly monitoring systems. There is a large choice now available in the market. Most require the elderly person to push a button in case of need.

The use of a low spatial resolution infrared thermopile array can solve many challenges induced by elders living on their own. It can be used to keep track of their location inside their home. At the same time their privacy is respected due to the low spatial resolution of the thermal sensor. Additionally, the sensor can be used to detect a fallen person and notify caregivers and relatives or release an alarm. Unusual situations can be monitored, for example if the person stays for unusual time at the same location. Further capabilities are fire detection and intrusion alarm, which can also be implemented with the same sensor. In case of dementia or Alzheimer's, a notification can be released if the person leaves an area. This enables the person to stay maximally independent, while easing their caregiver's and relative's stress.

Burglar Alarms

Burglar or intrusion alarming is an important application of thermal imaging. This can protect people, locations and assets and can reduce psychological damage by lowering stress.

Independent of external illumination, as it only depends on temperature sensing. It is also not affected by smoke, dust and light fog. Humans have a common temperature signature. This can be detected and classified even with a low number of pixels. This allows systematic distinguishing between humans and animals. Risk of false alarms is minimized through accurate intrusion classification.

The intrusion/burglar alarm function can be integrated via software in the same system which is used for the previously mentioned applications such as intelligent HVAC control, people counting and elderly people monitoring just by adding software functionality. If a building, office, or home is empty and the alarm function is activated, the sensor can be used to detect unauthorized persons and notify the owner and triggers an alarm sound.

For indoor alarms, the 32x32 thermopile array is normally sufficient, for outdoor perimeter intrusion detection systems a higher resolution like 80x64 or 120x84 is usually the better option depending on the area to be covered.

Smart Lighting

The ability to detect humans with Heimann thermopile array sensors can also be used to switch lights depending on presence. This is not only possible in smart homes and buildings, but also street lighting can be made smart by detect the presence of people and cars and adapt the lighting situation accordingly. This can save up to 70% of energy costs while still maintain safe streets.

With advanced analytical methods the intention of a person to enter the next room can be anticipated in software and the light will be switched on in advance.

Together with further smart home functionality like voice control and routines for changing light color and intensity based on the biorhythm (also referred to as "human-centric lighting"), the smart lighting is not only cost and energy efficient but provides also a comforting home environment. Combined with the burglar alarm the detection of an unwanted intruder can be used to turn on the lights, which could scare him out without leaving much damage.

Driver Assistance

Thermal imaging is an option to improve the driving experience in advanced driver assistance systems. While driver presence in many cases is not detected directly, but over secondary signals like fastened seat belt, closed door and seat occupancy sensor, thermal imaging allows direct detection of the presence of the driver and other passengers. This gives more reliable information about the presence of a driver, which may be important for (semi-)autonomous driving. For this kind of application thermopile arrays with a very large field of view of 90° and more can be used. It is also possible to detect if a person is sitting properly or out of position, or to detect a baby in a baby seat. This can be used to deactivate airbags automatically to reduce the risk of unwanted airbag induced injuries.

One single sensor can be utilized for a number of different tasks in a vehicle. If a person is detected on a specific seat, it can provide an information to fasten the corresponding seat belt. And with the ability to sense facial temperature, a drowsiness warning system can be implemented. Intelligent control of the car's air conditioning is possible. This improves the level of comfort and saves a lot of energy, which is especially important in electric vehicles as their available energy is limited. Other options are control of the electric parking brake or gesture control of the infotainment and navigation system.

Hot Spot Detection and Flagging

Because thermopile arrays gather thermal images, it follows that they can be easily employed for hot spot detection applications. There are many fields in which the information about existing or developing hot spots is useful regarding fire prevention, predictive maintenance, and energy savings. Typical applications for fire prevention and detection are stove top monitoring and fire risk detection in waste sorting plants, transportation, or public spaces. Examples for predictive maintenance are bearing temperature monitoring, observation of electrical components and connections as well as hot spot detection in photovoltaic plants.

Stove Top Monitoring

Kitchen fires starting from the stove are the number one cause in fires at home. In most countries there are no requirements for fire detectors in the kitchen because normal cooking procedures cause most fire detectors to give false alarms. But infrared thermopile detectors are not affected by haze or fog. So they can potentially make kitchen life safer. They can be used to monitor the stove top and shut it off before a critical temperature (e.g. ignition temperature of cooking oil) is reached.

In Scandinavian countries stove top monitoring systems of this type are mandatory. Preventing kitchen fires will also improve independence for people in assisted living situations with one big source of danger is eliminated.

Advantages of low-resolution thermopile arrays for stove top monitoring:

- Large temperature range up to 500°C and more
- Independent of haze and smoke
- No privacy issues due to low resolution

Recommended sensors:

- HTPA 8x8d
- HTPA 16x16d

Fire Risk Detection

50% of fires in factories, warehouses and processing plants are caused by faulty electrical connections and components. These fires often develop over hours and days from smoldering and braising fires. They can be detected with infrared thermal sensor arrays at a very early stage, often before the overheating component becomes defective or the electrical connection fails. This is possible because the components and connections get warmer than normal, leading to progressive degradation and early, sometimes catastrophic, failure.

Early fire risk detection systems should be installed in every production facility, warehouse, and every building with critical infrastructure. The consequences of a fire are much greater than the small investment needed. This is especially true for the installation of infrared thermopile array sensors as they are very effective for fire prevention and offer a good price performance ratio. This technology is far beyond conventional smoke detectors or fire detecting systems as it not only recognizes fire, but it foresees the future emergence of a fire event. This allows to prevent fires from arising at the first place and save time, money, and trust.

Fire risk detection systems based on thermopile array technology can also be implemented for fire prevention in waste sorting plants, in transportation like trains, aircraft or large ships or in computer server farms, where the thermal infrared sensor can also be used for predictive maintenance.

From a technical perspective the selection of the suitable sensor has to reflect the application scenario. To observe large areas or see even small fire risk spots higher spatial resolution is needed. This is also true if there is a large distance between sensor and observed area, e.g. in the case of a high ceiling. If small deviations in the temperature must be monitored, this will require also high thermal sensitivity. In many applications only the relative temperature information is important - is it hot compared to the rest of the scene? - and the calibration requirement is much less than for example in the case of human fever and elevated body temperature measurements.

Recommended sensors:

- HTPA 32x32d
- HTPA 80x64d

Predictive Maintenance

Besides detecting fires and preventing them from arising in the first place, thermopile arrays can "see" even more. Even small temperature anomalies in important locations, like e.g., electrical installations, can be detected. This allows prediction of potential failure of important components at an early stage. For example, if you can see machine bearings getting hotter than they should be, which is often a sign of an upcoming failure. The breakdown of a bearing could result in expensive damage and may bring production to a standstill for a long time. If you can predict the failure at a very early stage, the change of the bearing can be done in a routine maintenance, which saves both money and time.

The same principle can be applied to many other fields like heating, ventilation, and air conditioning systems, where clogged filters can be detected. Change in the temperature of electronic parts can indicate an likely future failure. This can be used to monitor photovoltaic plants to see in advance which cell will fail soon. Similarly for battery life management and safety, monitoring with thermal sensor arrays can be used to extend battery life and predict failure to prevent damage.

In principle all types of thermopile arrays can be used for predictive maintenance. In all cases the best sensor for a certain application has to be chosen carefully. Our specialized engineering team at Heimann Sensor will help you to select the right sensor taking into account both price and performance.

Tips and tricks for GUI design

How to obtain the best visual performance for your IR image



False color scaling limits:

These are the most important parameter and the first thing to look at. First thing is to understand the typical noise performance of the IR sensor. Since there is usually less signal on the outer pixels than on the central ones (due to vignetting and \cos^4 -law) but the electrical noise of each pixel is basically the same, pixels with larger distance from the center show generally a worse SNR. This effect leads to a higher NETD (**Noise Equivalent Temperature Difference**) for the pixels in the corner of the FPA (**Focal Plane Array**). For the extreme wide angled lenses corner pixels maybe even do not get any signal, rendering these pixels blind. This means these pixel will show extremely high noise, which can be multitudes higher than the actual content of the frame. Please find here an actual NETD plot for each pixel of an HTPA32x32d with a wide FOV (**Field of View**) optics:

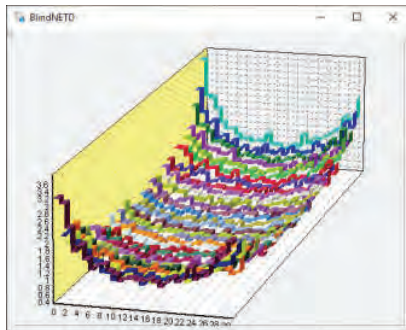

It can be seen, that the noise caused by the corner pixels is approximate 4 times higher than in the central area of the FPA. Therefore if your algorithm picks the minimum and maximum temperature in the frame and sets them to black respectively white (for a simple grey scale) the image will have a high flicker noise, since the corner values will shift the boundaries of the scale with each single frame. This leads to huge offset shifts of the color of the central pixels even if the scenery is timewise invariant.

Solutions for noise depression:

- Create the average of the i.e. three pixels with the lowest and highest reading and use that as the grey scale limits. This means that a small amount of pixels will be out of the scaling range, but the boundaries will be much more stable over time.
- Also, it is possible to use the average of the max/min reading in a moving average over time. This will decrease the noise on the boundaries as well.
- A combination of the two methods can be used as well. These two methods can be enabled with the "Smoothing" function in the Heimann Sensor GUI v2.
- Furthermore, a small hysteresis on the scaling algorithm also makes sense to avoid many dynamical changes of the content of the frame. If `scale.max` and `scale.min` is the actual max/min value of the scale and `frame.max` and `frame.min` are the values to be displayed this can be implemented like this:

```
bool ReScale=false;
if ((scale.max>(frame.max+AUTOSCALEHYST)) || (scale.max<(frame.max-AUTOSCALEHYST)))
    ReScale=true;
if ((scale.min>(frame.min+AUTOSCALEHYST)) || (scale.min<(frame.min-AUTOSCALEHYST)))
    ReScale=true;
```

AUTOSCALEHYST is a value, which needs to be determined in dependency of the system. The Heimann GUI v2 usually uses 0.8 in most cases.

Tips and tricks for GUI design



How to obtain the best visual performance for your IR image

Furthermore, the way the boundaries of the false color scale are determined has a high influence on the image quality. Especially in very high contrast scenarios it might make sense to set the grey scale not to the min or max value of the frame content. In example if there are humans and very hot objects in the image but the focus of the application lies on the humans, the max boundary should be set to a value which is slightly higher than the body temperature of the humans.

Solutions for min/max determination

These depend strongly on your application. In most scenarios a simple detection as described above (combined with the "Smoothing") is the best approach. Please check the manual scaling methods in the GUI v2 to get an overview on possible solutions. In example for the above described method a dynamic minimum scale, but a fixed maximum at 37°C will help tremendously to shift the dynamic range of the image towards the humans.

Graphic improvements

Noise depression

The noise in the image can be decreased by the following methods:

- Moving average of the readings of each pixels over time.
 - Pro/Con: Decreases the noise, but has a tremendous effect on the bandwidth → slow. Recommended for static or slow changing scenarios
- Adaptive averaging: This is basically also a moving averaging of each pixel over time, but with the precondition that the actual difference of the reading to the pre-calculated average must be smaller than a given threshold to apply the new average. If the difference is larger, than the actual reading is displayed. Otherwise, the moving average is displayed. Check the "AdapAv" option in the filter settings of the Heimann GUI v2. The threshold can be set in this case with the slider, but for a single system it can be set i.e. to five times the NETD of the system. The average is calculated in the GUI for four frames, but of course different values can be used.
 - Pro/Con: Good noise depression, but can generate "ghosts" in the image. Dynamic influence on the bandwidth of each pixel, which cannot be predicted.
- Low pass filters: In the GUI there are two low pass filters implemented. One IIR (**I**nfinite **I**mpulse **R**esponse) and a FIR (**F**inite **I**mpulse **R**esponse) low pass filters. These can cut of high frequent noise. Both are designed to a cut-off frequency of 3Hz when input is driven with 10Hz. They utilize a second order Bessel window. Code for these can be found in the subfolder "CodeExamples" of the GUIv2 folder.
 - Pro/Con: Very good high frequency noise depression without the huge influence on the bandwidth (approx. -20dB at 4Hz, but around -80dB for 5Hz). Both filters create a significant group delay, approx. 130ms for the IIR and 1.5s (!) for the FIR. Needs huge amounts of memory → $(TAP_NUM+1) * pixelcount$ of the device.

Tips and tricks for GUI design



How to obtain the best visual performance for your IR image

- Median filter: Can be used to get rid of “salt and pepper noise” while it doesn’t matter if this is static (offset differences of the pixel) or dynamic noise. This is a simple sorting of the eight adjacent neighbours of each pixel and taking the median of these readings for the central pixel reading. If there are large contrasts in the respective pixels the contrast may be reduced by taking simply the median. Therefore the Heimann GUIv2 utilizes a threshold, which determines below which contrast ratios of the respective pixels the median should be applied. A careful design of this threshold will show good results
 - Pro/Con: No influence on the bandwidth, needs small processing power and almost no memory. May decrease contrast (blurry image) if applied uncaredful and without threshold.

Interpolation

By using interpolation methods the resolution of the image can be enhanced. The easiest way to do this is the bilinear algorithm. Since this relatively trivial please refer to Wikipedia for this. Another way is the bicubic interpolation, which shows less artifacts but needs much more processing time. A bicubic interpolation algorithm can be found as plain c-code in the “CodeExamples” folder of the GUIv2 subfolder.

Bilinear algorithm (left) compared to the bicubic (right)

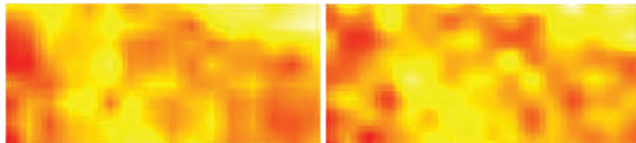

Cleaning and Handling of Sensors with Optical Elements

Cleaning of Filter with Isopropyl Alcohol or Acetone

This is the method most universally used for cleaning optical elements with or without coatings. Filters or lenses mounted in our sensors may be cleaned rubbing the surfaces lightly with a clean, soft, all-cotton cloth or cotton swab during immersion in solvent or simply moistened with the solvent. The parts are then immediately wiped dry with another clean, soft, all-cotton cloth or cotton swab.

Cleaning with Detergent and Water

A very mild, non-abrasive detergent (one which does not contain additives) and water may also be used for cleaning optical elements. In general, a detergent and water mixture is an excellent method for removing fingerprints and other smudges. The liquid detergent is first mixed with deionized water (proportions recommended by the manufacturer should be followed). The element is then washed, rinsed, and immediately wiped dry. Use a clean, soft cloth when cleaning and drying. If the part is allowed to dry in air, a permanent stain may result.

Please note:

- Do not use isopropyl alcohol or acetone or detergent if the elements will be mounted in an assembly with a finish which may be soluble by these solvents.
- Please avoid glass isolation being moistened by solvent.
- If the part is allowed to dry in air, a permanent stain may result.

Handling Advises

Sensors with optical elements deserve special consideration in their handling and care. Ordinarily, filters or lenses are cleaned and inspected prior to shipment. If proper care is exercised during handling cleaning should not be necessary prior to use.

- Wear gloves when handling a sensor or optical element. Lightweight nylon or cotton gloves which are relatively lint-free are recommended.
- Avoid touching the surface of filters and lenses.
- Protect devices from static discharge and static fields.
- Thermopile sensors are electrostatic sensitive devices. Sensors should be handled over an electrostatic protected work area.
- Precautions should be taken to avoid reverse polarity of power supply for sensors with integrated signal processing. Reversed polarity of power supply results in a destroyed unit.
- Sensors should rest preferably in a partitioned container where the mounted filters or lenses will be not coming into contact with other material.
- During storage optical surfaces should be covered to avoid contamination from the surrounding environment.
- A covered container can eliminate damage during transportation and storage.
- Sensors or optical elements should be stored in a restricted access area to eliminate handling by untrained personnel.
- Do not expose the sensors to aggressive detergents such as freon, trichlorethylen, etc.
- Avoid rotating the sensors when they are soldered into a PCB or something similar
- Shortening of the pins is not suggested. This may cause cracks in the glass of the pins and result in a leakage.
 - If this is necessary, a tool for this is recommended. Please contact Heimann Sensor for further information.

Soldering Recommendations

Attention: For all of our array sensors we give no guarantee on the calibration and its performance if the pins are shortened by the customer. Additionally we strongly recommend to not soldering the sensor with its back plate directly to a PCB. This will cause different thermal conductivity compared to air and the measurement results could get worse. Use a minimum gap between PCB and backplate of 2mm or more. The glass of the pins to the back plate can get damage by applying high temperatures (during soldering), which will lead into a lower temperature reading what cannot be repaired afterwards.

Manual Iron Soldering and Automatic Point-to-Point Iron Soldering

Manual Iron Soldering and Automatic Point-to-Point Iron Soldering methods are allowed for TO packages. It is recommended for through hole applications to shield the package body from soldering heat by PCB or similar.

The soldering iron temperature should be set as low as possible (maximum 350°C) and should not exceed recommended soldering time (maximum 5 seconds).

Wave Soldering

Wave soldering is not recommended for Surface Mounted Device packages.

Wave soldering is allowed for through hole application. A pre-heating step is required and should be performed in accordance with international standard recommendations. For TO packaged products, during the pre-heat and soldering phase, the temperature of the body shall not exceed 170°C.

Reflow Soldering

Reflow techniques can be used to solder Surface Mounted Device packages. Temperature profile should conform to those described in Jedec-020 standard (recommended reflow furnace profile below). Reflow soldering creates a risk for exposing the sensor body to excessive temperatures around and above the TG of used epoxies. Process validation has been carried out by samples exposed to maximum temperature of below furnace profile.

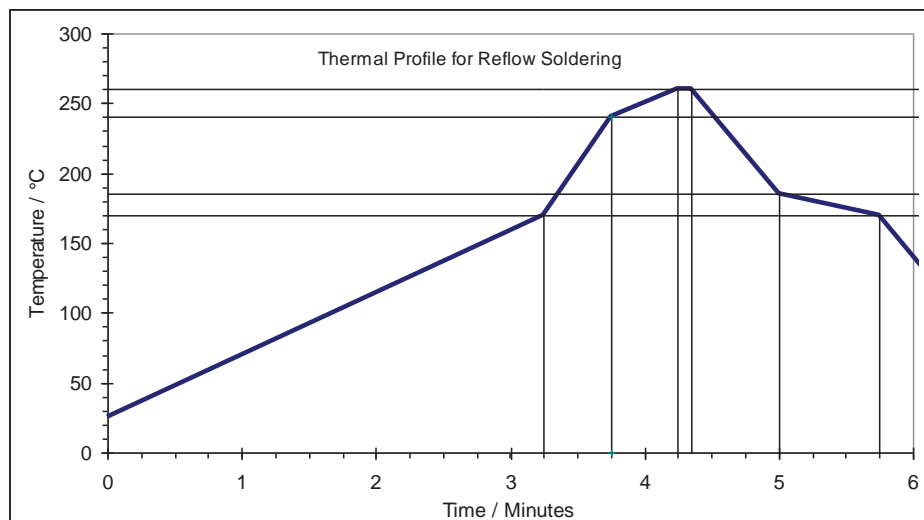

Disclaimer

Although these Recommendations are presented in good faith and believed to be correct, Heimann Sensor makes no representations or warranties as to the completeness or accuracy of these recommendations. The recommendations therefore are supplied upon the express condition that the persons and/or

companies receiving them will make their own determination as to the suitability of these recommendations for the intended purposes prior to use.

In no event will Heimann Sensor be responsible for damages of any nature whatsoever resulting from the use of or reliance upon the recommendations.

No representations or warranties, either express or implied, of fitness for a particular purpose or of any other nature are made hereunder with respect to these recommendations.

Notwithstanding any other provision in these recommendations, the customer will remain solely responsible for its soldering process.



Visible camera

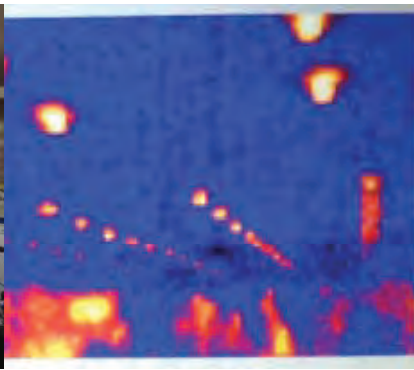

IR camera

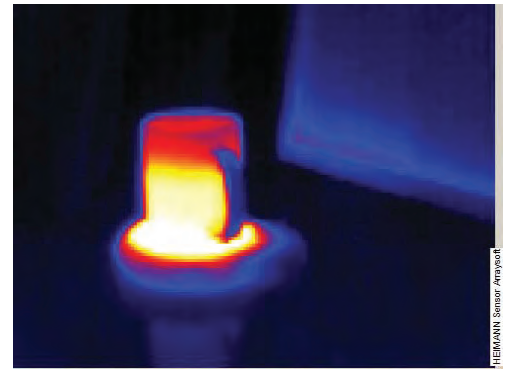

Coffee mug on warmer



Hand gesture recognition



Hand with watch and ring

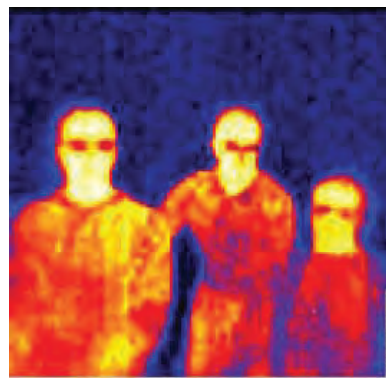

Group photo

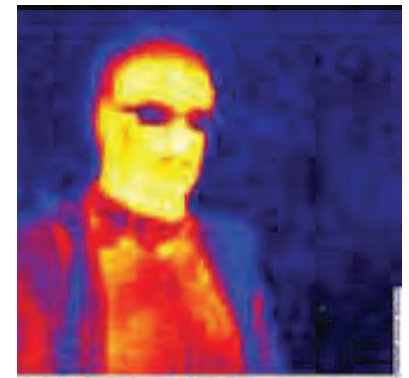

Portrait of the boss



Elevated temperature detection