

Thermal Product Catalog

Thermal Products

This catalog includes standard heatsink products for testing purposes which are suitable for each of the standard UV LED product lines, as well as information on thermal services for custom cooling solutions.

Thermal Product Catalog

Standard Heatsink Products

Violumas standard heatsink products are not optimized for unique systems and are primarily meant to be utilized for testing purposes.

- Each product has been tested under the condition of $T_a=25^{\circ}\text{C}$ and maintains the junction temperature of the LED below 75°C .
- Each standard heatsink is provided with mounting screws for the associated COB product.
- Thermal pads can be provided as suitable TIM (thermal interface material). For higher power COB products, samples of thermal grease may be available upon request.
- For instructions on properly mounting the LED on a heatsink, please refer to the Application Note: Mounting LEDs on Heatsinks.

Precaution: Please do not operate Violumas LEDs without a proper cooling solution. Operating the LED without a heatsink may result in immediate failure and Violumas will not be responsible for replacement.

Heatsink Part Number	Description	Catalog Page No.
30.1.006770	Heatsink for VC1X1 COB Series	2
30.1.006846	Heatsink for VC2X2 COB Series	3
30.3.006733	Heatsink for VC12X1 COB Series	4
30.4988.10	Fan-Cooled Heatsink for VC4X2 & VC2X2 COB Series	5
30.4988.30	Fan-Cooled Heatsink for VC3X3 & VC4X4 COB Series	6
30.2.012424	Heatsink for VioBeam-1X1 COB Series	7

Thermal Services: Simulation & Design

For the integration of LEDs or LED arrays into specified systems, many off-the-shelf heatsink solutions may not suffice as proper cooling solutions. Designing a proper cooling solution may take the following parameters into consideration:

- Lifetime requirements of the system
- Mechanical requirements of the system
- Thermal budget

Violumas offers thermal modeling and design services to provide customized passive, active, and liquid cooling solutions to optimize reliability while keeping your specific system requirements in mind.

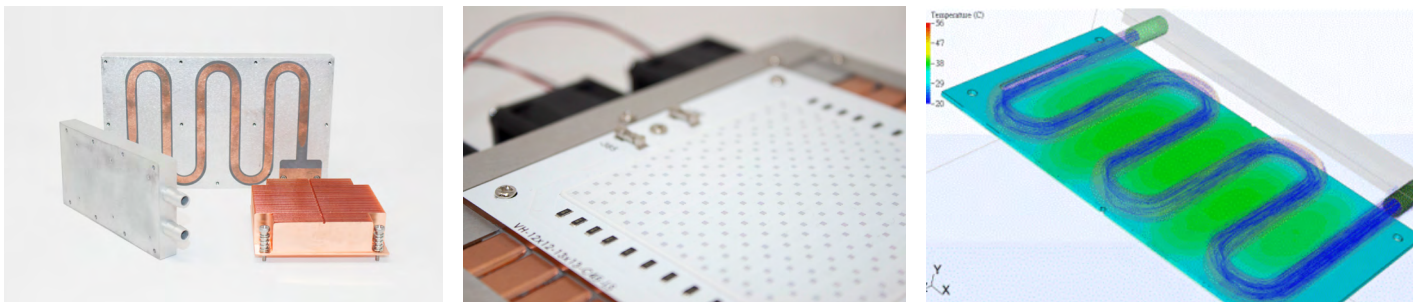

Contact the Violumas team to learn more about thermal services.

30.1.006770 (Heatsink for VC1X1 COB Series)

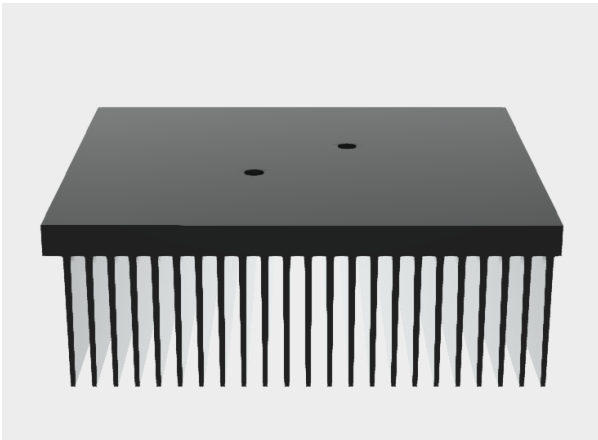

- Suitable LED Models: VC1X1 COB Series (pre-drilled mounting holes)
- Thermal Capacity: 6 W
- Dimensions: 50 x 55.75 x 18.87 mm
- Weight: 57 g
- Material: Aluminum
- Product Includes: Heatsink (1), M3 Screws (2)
- Available Upon Request: Thermal Pad

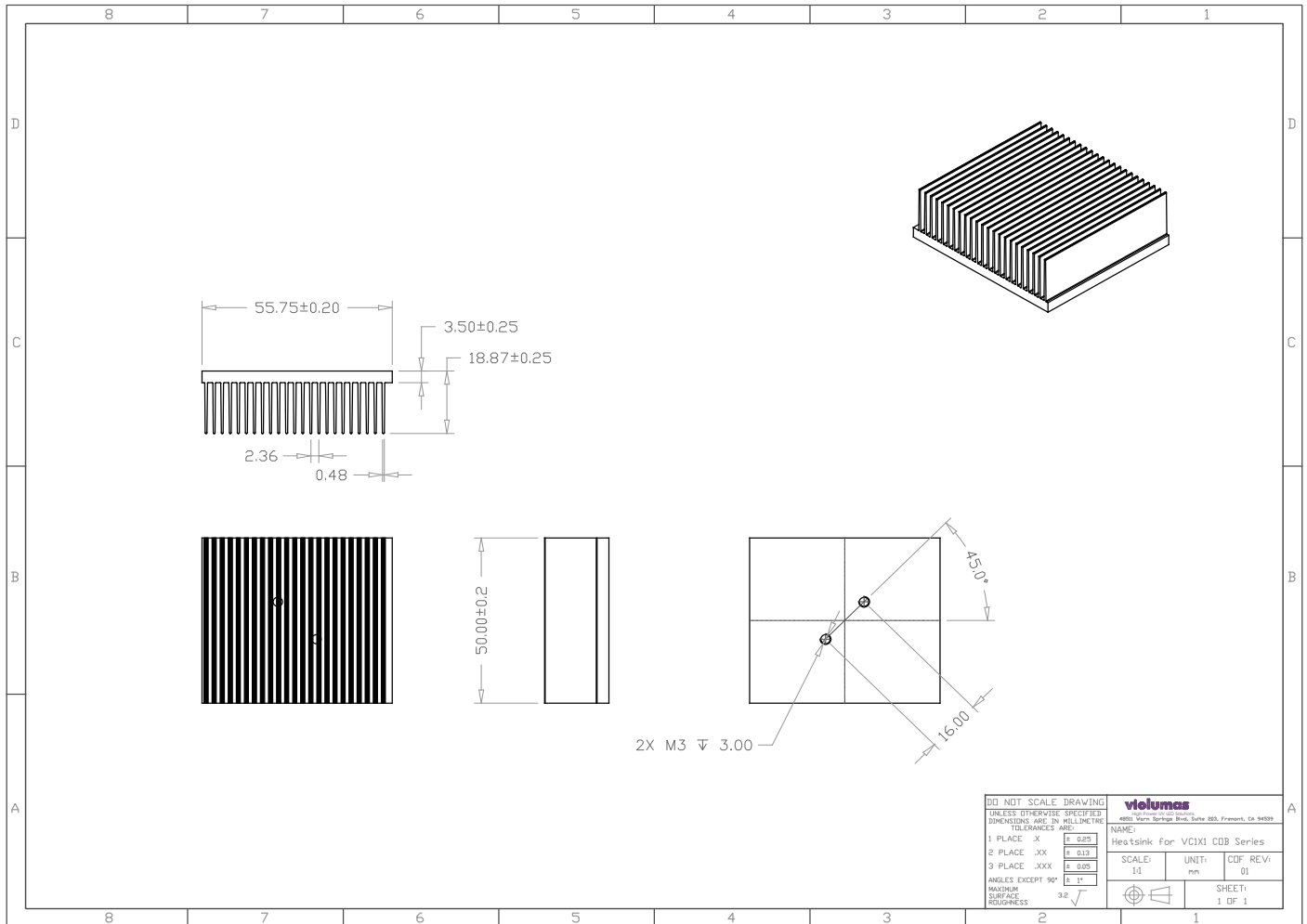

30.1.006846 (Heatsink for VC2X2 COB Series)

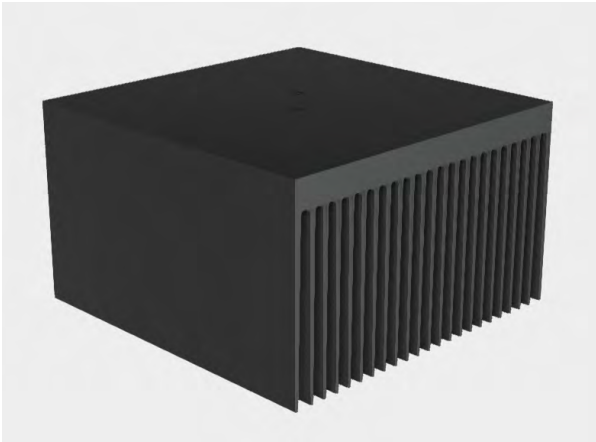

- Suitable LED Models: VC2X2 COB Series (pre-drilled mounting holes)
- Thermal Capacity: 20 W
- Dimensions: 99.57 x 99.57 x 58.92 mm
- Weight: 644 g
- Material: Aluminum (Black Anodized)
- Product Includes: Heatsink (1), M3 Screws (2)
- Available Upon Request: Thermal Pad

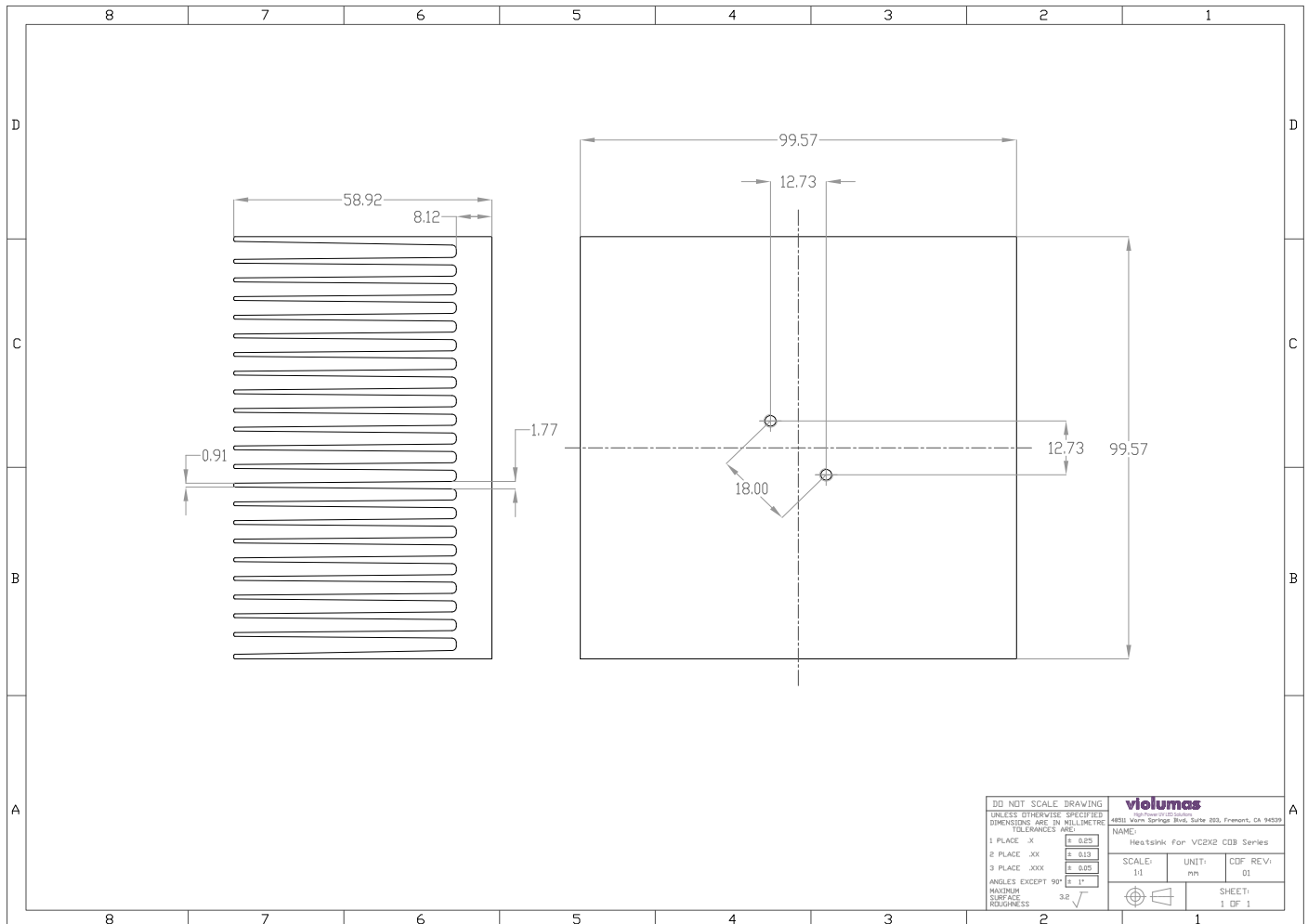

30.3.006733 (Heatsink for VC12X1 COB Series)

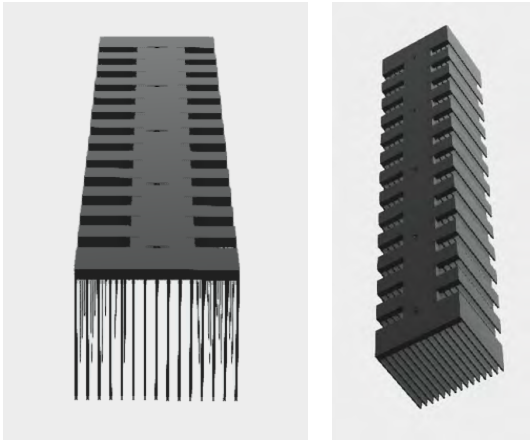

- Suitable LED Models: VC12X1 COB Series (pre-drilled mounting holes)
- Thermal Capacity: 60 W
- Dimensions: 304.8 x 52 x 45 mm
- Weight: 385 g
- Material: Aluminum (Black Anodized)
- Product Includes: Heatsink (1), M3 Screws (5)

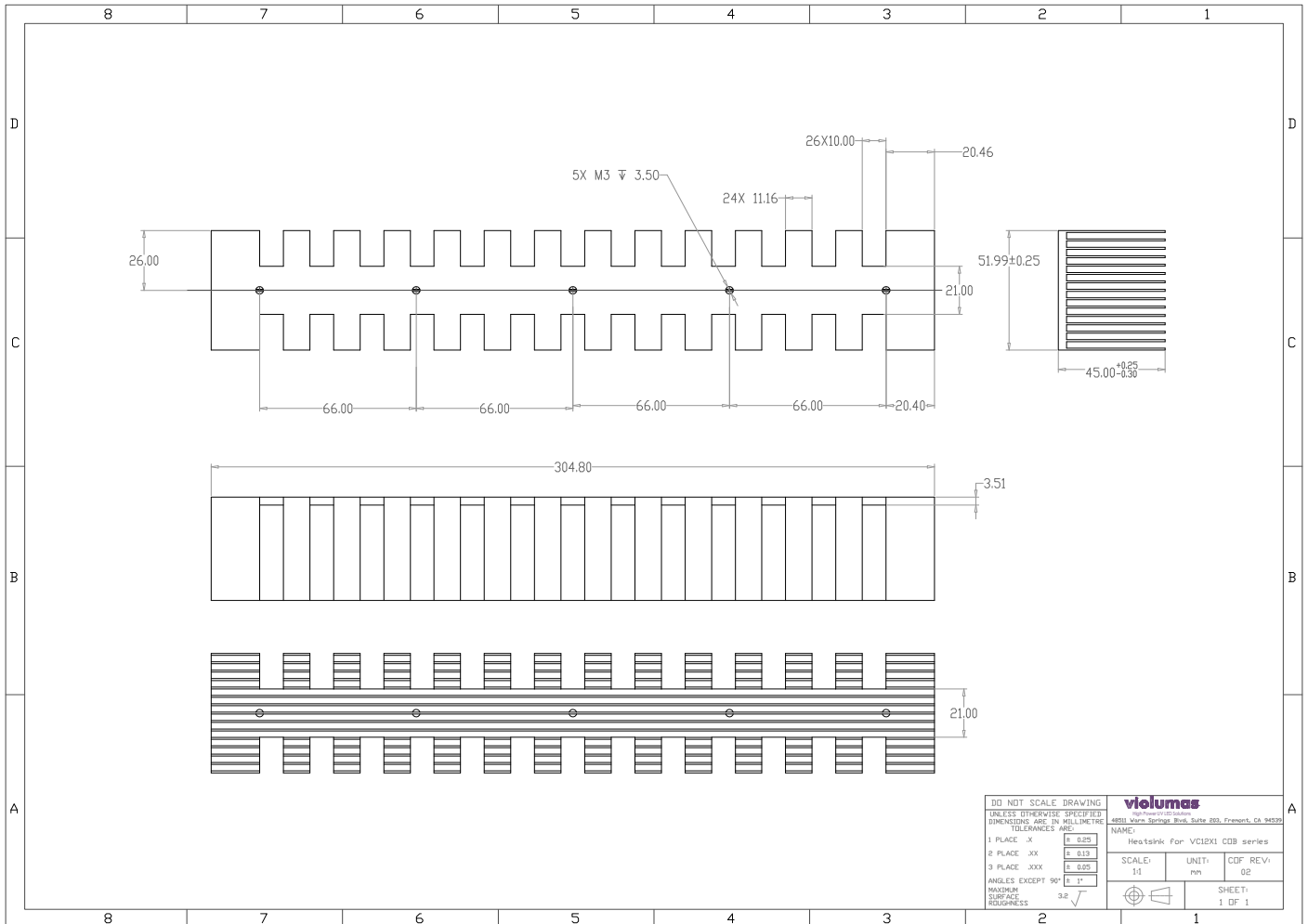

30.4988.10 (Fan-Cooled Heatsink for VC2X2 & VC4X2 COB Series)

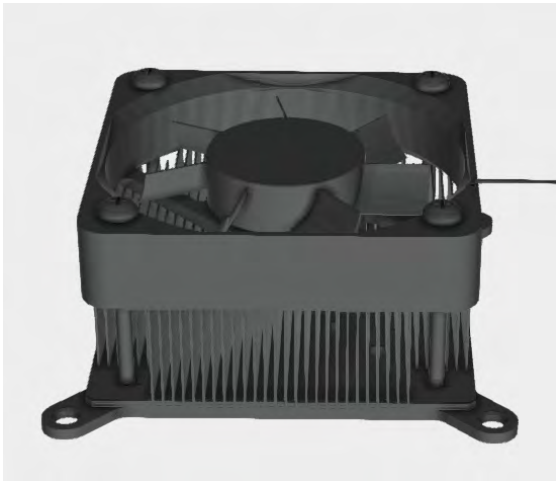

- Suitable LED Models: VC2X2 COB Series, VC4X2 COB Series (pre-drilled mounting holes)
- Thermal Capacity: 50 W
- Dimensions: 60.35 x 60.35 x 26.5 mm
- Weight: 64 g
- Material: Aluminum (Black Anodized)
- Product Includes: Heatsink with Fan (1), M3 Screws (2)
- Available Upon Request: Fan Driver Kit

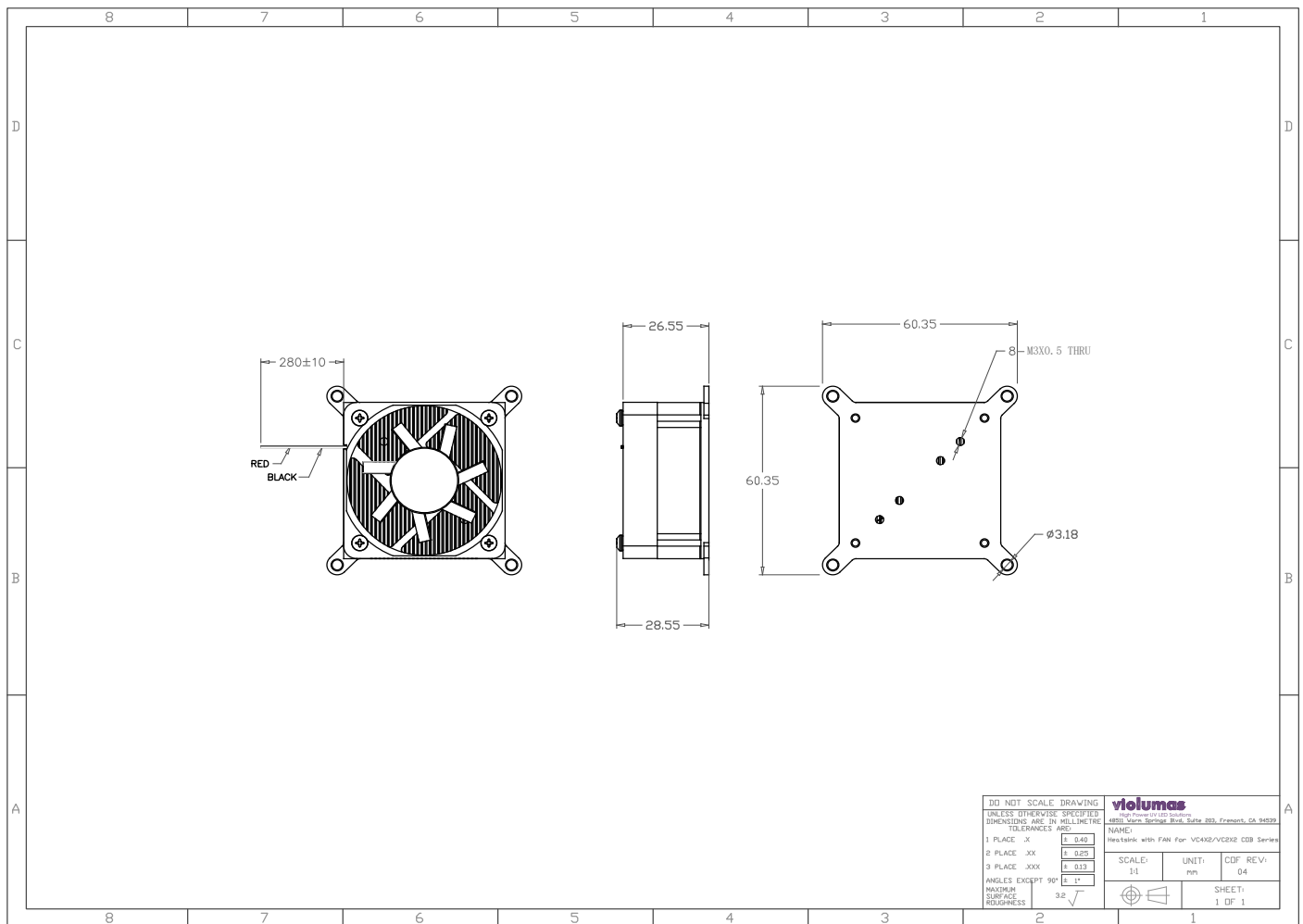

30.4988.30 (Fan-Cooled Heatsink for VC3X3 & VC4X4 COB Series)



- Suitable LED Models: VC3X3 COB Series, VC4X4 COB Series (pre-drilled mounting holes)
- Thermal Capacity: 60 W
- Dimensions: 83 x 80 x 69 mm
- Weight: 440 g
- Material: Aluminum (Black Anodized)
- Product Includes: Heatsink with Fan (1), M3 Screws (2)
- Available Upon Request: Fan Driver Kit, Module Assembly

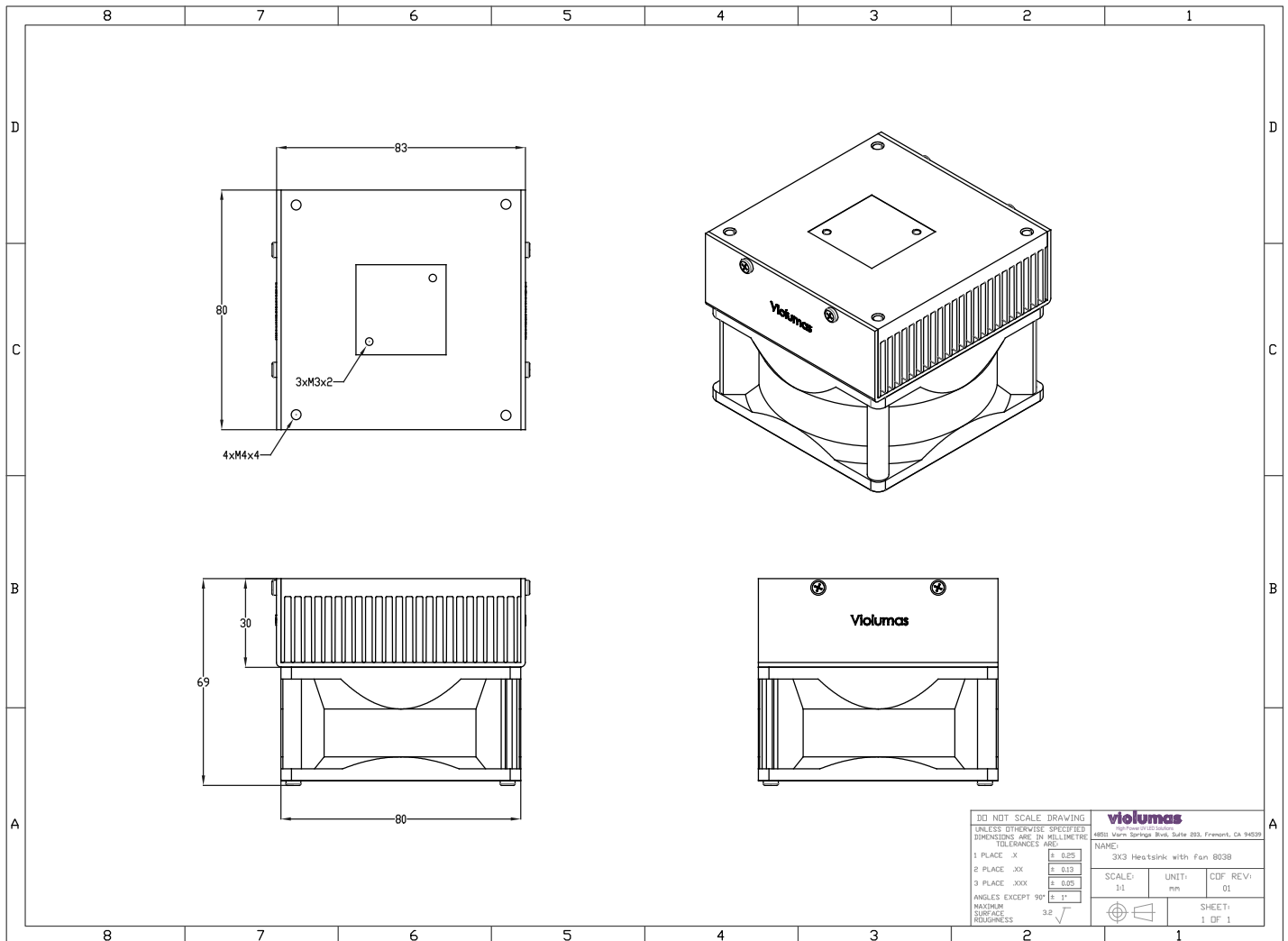

30.2.012424 (Heatsink for VioBeam-1X1 COB Series)

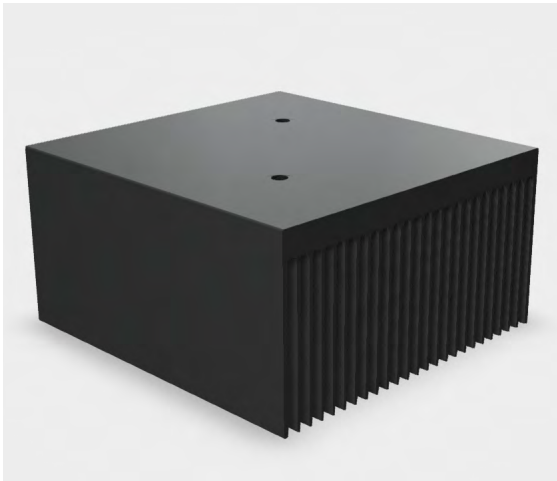

- Suitable LED Models: VioBeam-1X1 COB Series (pre-drilled mounting holes)
- Thermal Capacity: 8 W
- Dimensions: 58 x 60 x 30.8 mm
- Weight: 97 g
- Material: Aluminum (Black Anodized)
- Product Includes: Heatsink (1), M3 Screws (2)
- Available Upon Request: Thermal Pad

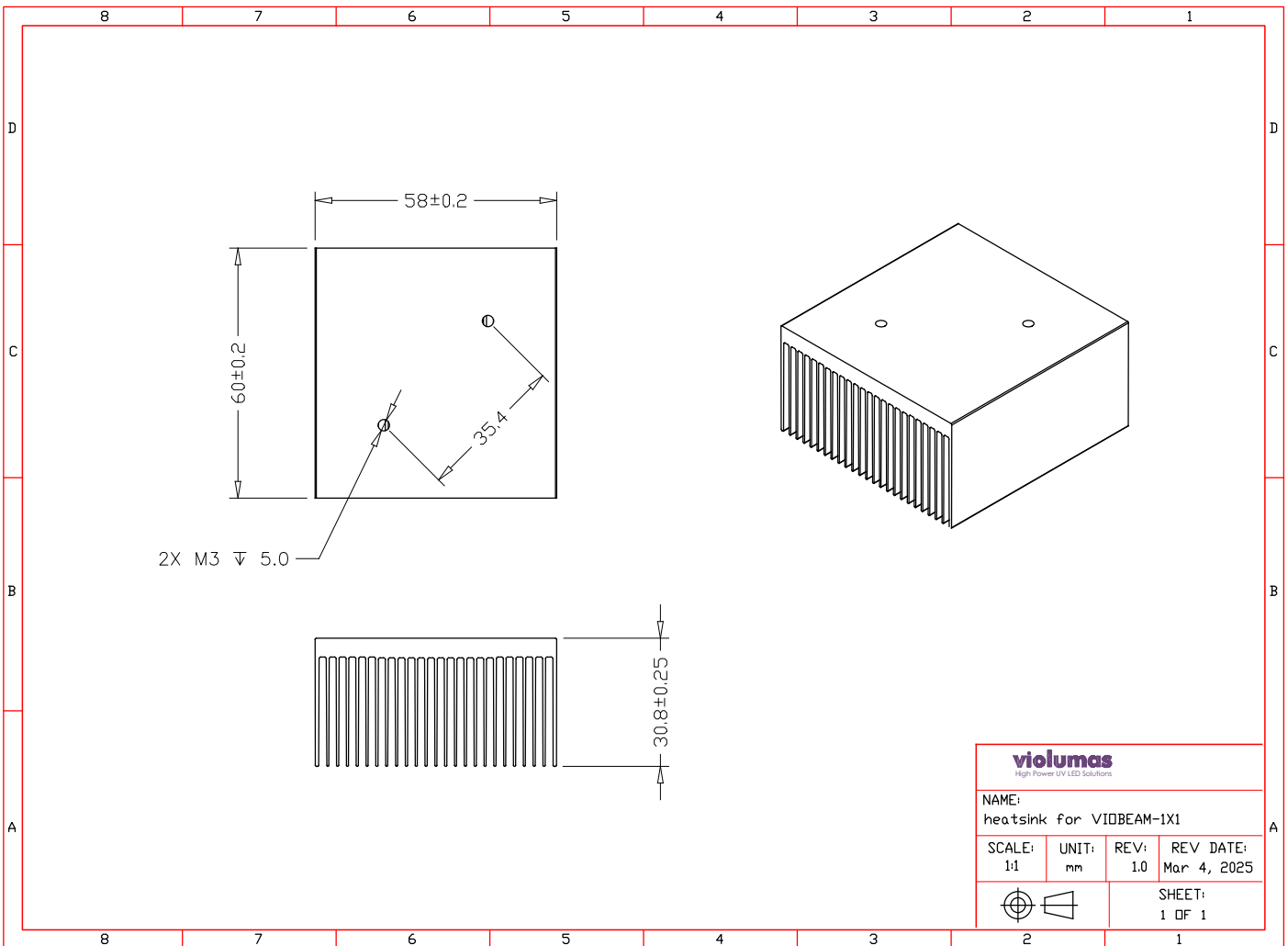



Application Note

Mounting LEDs on Heatsinks

This application note will provide guidance on the selection of appropriate cooling solutions and the recommended method of mounting an LED on a heatsink.

Mounting LEDs on Heatsinks

Overview

LEDs are subject to heat generation and may suffer from early failure and thermal damage if operated without an appropriate thermal management solution. A suitable cooling solution (usually in the form of a heatsink, fanned heatsink, or cold plate) must be utilized to ensure the junction temperature of an LED is maintained within an acceptable range. Operating LEDs at high junction temperatures can reduce the performance and reliability of the device and the system. This guideline is provided as a resource for the selection of appropriate cooling solutions and the proper method of mounting an LED onto a heatsink.

Disclaimer: Please do not operate Violumas LEDs without a proper cooling solution. Operating the LED without a heatsink may result in immediate failure and Violumas will not be responsible for replacement. Violumas cannot be held responsible for any damages caused by following these guidelines as this document provides generic guidelines for heatsink mounting and does not intend to replace standard engineering practices.

Part 1: Selection of Cooling Solutions

A proper cooling solution must be selected by carefully considering the overall wattage, thermal density, and size of the LED or LED array. The LED datasheet should be referred to for information regarding the thermal resistance of the LED and absolute maximum ratings for junction temperature. The absolute maximum ratings for junction temperature should never be exceeded, and keeping the LED junction temperature as low as possible will result in increased reliability and performance.

Violumas provides heatsink products for testing purposes which are suitable for each of the standard LED product lines. For the integration of LEDs and LED arrays into specified systems and enclosures, Violumas provides thermal modeling and design services in order to maintain proper junction temperatures within a specific system.

Applicable Violumas Products

- 30.1.006770 (Heatsink for VC1X1 COB Series)
- 30.1.006846 (Heatsink for VC2X2 COB Series)
- 30.4988.10 (Heatsink with Fan for VC4X2 or VC2X2 COB Series)
- 30.3.006733 (Heatsink for VC12X1 COB Series)

Please refer to the Violumas Thermal Products Catalog for more information regarding heatsinks and thermal services.

Part 2: Assembly with Thermal Pads

For testing purposes, Violumas provides thermal kits for its standard product lines VC1X1 COB Series and VC2X2 COB Series. The thermal kit includes: heatsink (1), thermal pad (1), and screws (2) which are suitable for the specified LED product. The following instructions can be utilized for assembly of LEDs to heatsinks with appropriate thermal pad material.

Necessary Materials

- Violumas LED (COB or SMD mounted on PCB)
- Heatsink with Mounting Screws
- Thermal Pad
- Isopropyl Alcohol

Step by Step Guidelines

1) Inspect the contact surfaces.

- If there is a protective film on the backside of the LED, please remove the film.
- Before assembly, ensure the contact surface of the LED backside and heatsink are smooth.
- If surfaces are not smooth, high resolution sandpaper polish is recommended.
- Gently clean the surfaces with alcohol.

2) Apply thermal pad as TIM (thermal interface material).

- Place the thermal pad on the coupling area where the LED is to be mounted onto the heatsink.

3) Tighten down the LED onto the heatsink surface via screws.

- M3 or M4 screws are provided to ensure the mechanical pressure is evenly applied.
- Do not overtorque the screws.

Part 3: Assembly with Thermal Grease

While thermal pads can be easier to install, for high power LED products, such as larger LED arrays with electrical wattages surpassing 10 W, Violumas recommends the use of thermal grease or paste as an enhanced thermal conduction material.

Necessary Materials

- Violumas LED (COB or SMD mounted on PCB)
- Heatsink with Mounting Screws
- Thermal Grease*
- Putty Knife
- Isopropyl Alcohol

*There are many thermal grease product options available. The use of a ceramic-based thermal grease is recommended (as opposed to metal-based thermal grease) due to the lower electrical conductivity. Violumas recommends a minimum thermal conductivity value of 2W/mK. Please contact the Violumas team for specific recommendations on appropriate thermal grease materials.

Step by Step Guidelines

1) Inspect the contact surfaces.

- If there is a protective film on the backside of the LED, please remove the film.
- Before assembly, ensure the contact surface of the LED backside and heatsink are smooth.
- If surfaces are not smooth, high resolution sandpaper polish is recommended.
- Gently clean the surfaces with alcohol.

2) Apply thermal grease as TIM (thermal interface material).

- Apply thermal grease on the backside of the LED and the coupling area on the heatsink.
- Use a putty knife to ensure the thermal grease is as thin and evenly spread as possible.

3) Tighten down the LED onto the heatsink surface via screws.

- M3 or M4 screws are provided to ensure the mechanical pressure is evenly applied.
- While tightening the screws, avoid uneven tilting and air bubbles/gaps between the LED and heatsink. Do not overtorque the screws.
- Proper precautions must be taken to ensure proper contact by tightening the screws when the LED is powered on.