

## M3X3L9 Series 3X3 UV LED Module

**M3X3L9 Series** is a UV LED module comprised of a VC3X3 UV LED COB and a fan-cooled heatsink for a complete, validated product ready for testing and integration. Utilizing the patented 3-PAD LED Flip Chip and Super Pillar MCPCB, the COB array is structured with a high density 9-chip LED array under a single 90° fused silica lens, allowing for focused, high-power illumination. A specially designed fan-cooled heatsink ensures temperature and performance stability, and a dimmable LED driver kit and fan power supply can be provided for a fully-equipped system kit.

### FEATURES & BENEFITS

- Equipped with VC3X3 LED COB & 90° fused silica lens
- Available in 265nm, 275nm, 295nm, and 310nm
- Dimensions: 83mm x 80mm x 75mm
- Ready for testing and integration with validated thermal solution



### MODULE CONFIGURATIONS

Module Part Number	Included Parts	Description
M3X3L9-265	VC3X3C48L9-265	3X3 UVC LED COB, Wavelength: 265nm +/-5nm, Lens: 90°
	30.4988.30	Fan-Cooled Heatsink for VC3X3 COB Series
M3X3L9-275	VC3X3C48L9-275	3X3 UVC LED COB, Wavelength: 275nm +/-5nm, Lens: 90°
	30.4988.30	Fan-Cooled Heatsink for VC3X3 COB Series
M3X3L9-295	VC3X3C48L9-295	3X3 UVB LED COB, Wavelength: 295nm +/-5nm, Lens: 90°
	30.4988.30	Fan-Cooled Heatsink for VC3X3 COB Series
M3X3L9-310-V1	VC3X3C48L9-310-V1	3X3 UVB LED COB, Wavelength: 308nm +/-5nm, Lens: 90°
	30.4988.30	Fan-Cooled Heatsink for VC3X3 COB Series

## Mechanical Dimensions

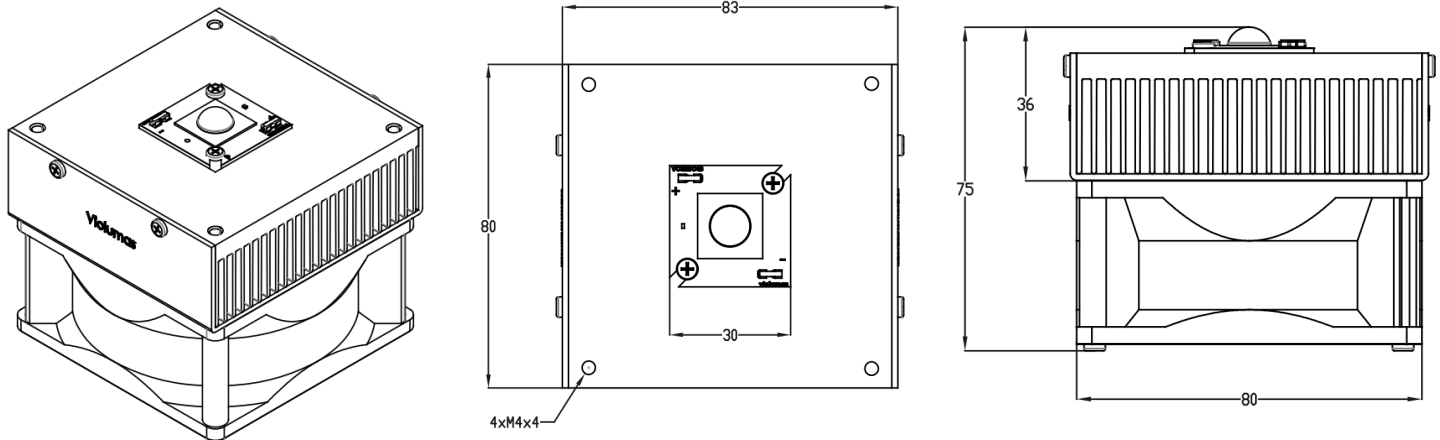

## Operation Guidelines

All M3X3L9 products will be provided with the LED COB mounted onto the heatsink surface (with the application of thermal grease). COB wires will be pre-attached. Driver kits for the COB and fan-cooled heatsink must be purchased separately.

1. Couple the fan wires to the fan power supply wires. Plug the fan power supply into a power strip with an ON/OFF switch.
2. Turn on the fan before turning on any other devices.
3. Couple the COB wires to the LED power supply wires. Plug the LED driver kit into a power strip with an ON/OFF switch. Ensure that the driving current is set to the lowest setting before turning on the device.
4. Turn on the LED driver kit and slowly increase the driving current until the target current value is reached.

*Notes: Please connect all power supplies to a separate power strip (not provided) with an ON/OFF switch. Please utilize the power strip switch to turn the drivers on and off. Directly plugging the driver kit into a wall outlet is not recommended. Please ensure that there is space beneath the fan to enable sufficient air flow; we recommend leaving at least 5 cm of space between the fan and any obstacles (e.g. tabletop surface).*

## Driver Accessories

### PS-2100A50W Driver Kit

Driver kit for VC3X3 COB Series



### PS-1A12V-FAN Driver Kit

Driver kit for 30.4988.30 Fan-Cooled Heatsink



Full catalog of driver kit products can be found at <https://www.violumas.com/heatsinks-drivers/>.

## Electro-Optical Characteristics for VC3X3C48L9 Series ( $T_A=25^\circ\text{C}$ and $I_F=2100\text{mA}$ )

Part Number	Wavelength	Typ. Output	Forward Voltage	Power Consumption
VC3X3C48L9-265	265nm	635mW	18.0V	37.8W
VC3X3C48L9-275	275nm	675mW	18.0V	37.8W
VC3X3C48L9-295	295nm	720mW	17.4V	36.5W
VC3X3C48L9-310-V1	308nm	900mW	17.7V	37.2W

Please see COB datasheet for full specifications including absolute maximum ratings, spectrum plots, characteristic curves, and radiation patterns (<https://www.violumas.com/cob-modules/>).

## Irradiance Simulations ( $T_A=25^\circ\text{C}$ and $I_F=2100\text{mA}$ )

Irradiance plots below are simulated at throw distance of 10 cm and detector area of 100 cm<sup>2</sup>.

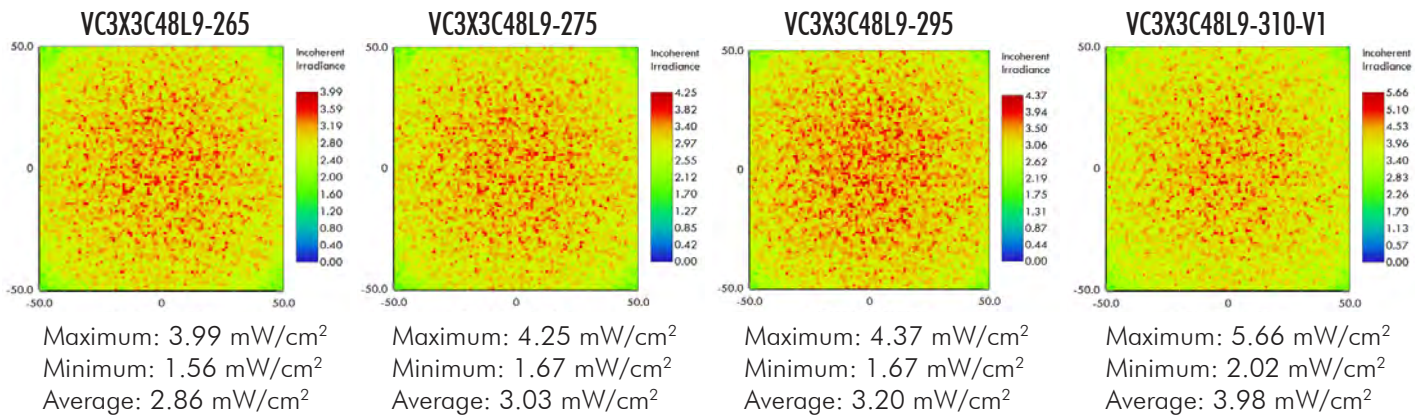

Irradiance plots below are simulated at throw distance of 10 mm and detector area of 100 cm<sup>2</sup>.

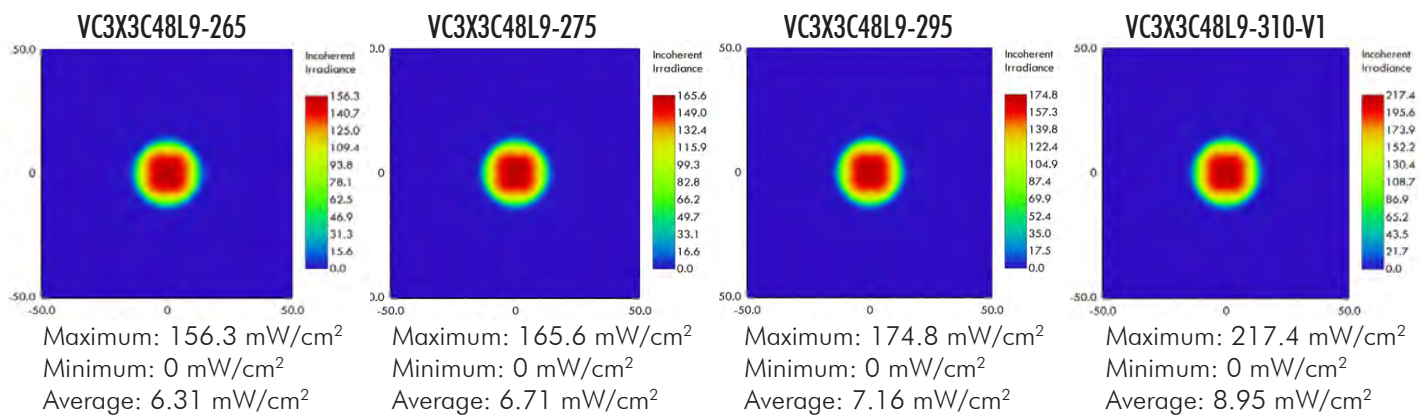

Please contact the Violumas team for further information regarding simulated irradiance plots at alternative distances and detector areas.

## Handling & Usage Precautions

- Exhibit extreme care when handling LEDs. Do not touch the LED with bare hands as doing so may contaminate and affect the optical characteristics of the LED. When using tweezers, do not apply excessive force, especially to the glass lens. Do not drop the LED as doing so may cause product damage.
- Ensure that electrostatic discharge specifications are followed. Static electricity and surge voltages may cause product damage. Proper electrostatic discharge protection equipment, working machinery, and protected mounting equipment are recommended.
- Do not expose the LEDs to volatile organic compounds as well as hazardous, acidic, and corrosive substances during storage and operation to avoid product damage.
- Do not apply excess mechanical force and vibration while handling the product.
- Do not expose the product to sudden changes in temperature, high humidity levels, and condensation.
- Ensure that the PCB is suitable for the product and be wary of LED placement and possible PCB warpage.
- To avoid fault issues, do not couple any electrical wires to the metal substrate of the MCPCB or COB. If any electrical wires from the power source have contact with the MCPCB's metal base under power ON conditions, permanent damage may occur due to inner arcing within the 3-PAD LED structure.

## Storage Precautions

- Perform soldering as soon as the moisture-proof packaging is opened.
- After the storage duration has exceeded the recommended time, products may need to be baked before soldering.
- Store all products in a controlled environment under 30° C free of dust. Do not expose the product to sudden changes in temperature, high humidity levels, and condensation.
- Please consult the Violumas engineering team for further information on storage precautions.

## Eye Safety Precautions

- Avoid exposure to UV light during LED operation. Do not look directly into the UV light during LED operation. Do not look directly into the UV light during optical measurements even through optical instruments. Protect the body, skin, and eyes with UV protective equipment.
- Attach warning labels on all products and systems that use UV LEDs.

## Cleaning Precautions

- Do not use brushes or organic solvents for cleaning the LEDs.
- Perform electrical and optical measurements before and after cleaning to ensure optimal performance.

## Static Electricity Precautions

- Ensure that equipment and machinery are properly grounded.
- Anti-electrostatic attire (wristbands, gloves, footwear, etc.) is recommended.
- Damage inspection is recommended while performing characteristics inspection of LEDs.

## Disclaimers

Violumas is not responsible for any damages that result from inaccurate use of the recommended guidelines. The information compiled in this document is a result of careful review of reference materials and reliable sources. Violumas does not make any claims regarding warranty or guarantee. It is recommended that each customer consults the Violumas engineering team before engaging Violumas products in extreme applications where the failure of the LED and damage to human health may be possible. Each user assumes full responsibility for determining the suitability of the use of Violumas products in various applications. Disassembling Violumas products without consent is prohibited. No part of these documents may be reproduced in any form without prior written permission from Violumas. Please note that the data presented in this document is measured from the use of exclusive Flip Chip Opto patented products - the 3-PAD LED Flip Chip and the Pillar MCPCB.