

UV-Index Measurement

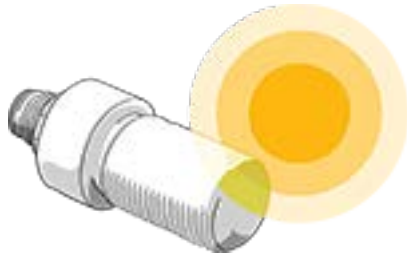

- **Photodiodes for measurement of the UV Index, various optics and detector chip areas**
- **UV sensors (TOCONs) with 0 to 5 V voltage output for measurement of the UV Index, various optics**
- **UV sensor probes for measurement of the UV Index, cosine field of view**
- **UV index reference radiometers**



 **Boston**Electronics

91 Boylston Street, Brookline, MA 02445
tel: (617)566-3821 shop.boselec.com
www.boselec.com boselec@boselec.com



UV-Index photodiode SG01L-E5

UV-Index measurement, SiC UV photodiode, erythema filter, chip active area = 1.00 mm², TO5 housing



UV-Index sensor TOCON_E2

UV-Index measurement, SiC UV sensor, integrated amplifier, signal output 0-5 V, with erythema filter, measurements up to UVI 30 , TO5 housing with diffusor (cosine corrected), individual conversion factor from Index to output voltage is included in the price



UV-Index sensor TOCON_UVI

UV-Index measurement, TOCON_E2 (SiC UV-Index sensor) in a PTFE housing, with G1/4" thread, water proof, EMC safe, with erythema filter and cosine correction for UVI measurements up to 30



UV-Index sensor probe UV-Cosine_UVI (ERYCA)

UV-Index measurement, UV sensor probe ERYCA, water proof, EMC safe, with cosine FOV and erythema filter



UV-Index sensor probe UV-Surface_UVI

UV-Index measurement, UV sensor probe, EMC safe, with cosine FOV and erythema filter



stand-alone UV Index Transmitter

The solar cell powered stand-alone UV Index transmitter measures the UV Index according to the standard ISO17166:2019 and the WHO requirements. The unit transmits the current UV Index via cellular radio to a server where the obtained values are stored. The unit bases on the UV sensor “sglux ERYCA” that is featured by a spectral responsivity very close to the erythema action curve). Set-up and use of the UV Index transmitter does not require specific metrological or computer knowledge.



Safester UVI

Smartphone-based measuring device for risk assessment of solar UV radiation on workplaces according to standard ISO 17166 (UV index). The device is configured and calibrated according to the instructions from ISO 17166.



UVI-Solo

The UVI-Solo is a waterproof pole or railings mounted high accuracy UV-Index sensor. The integrated leveling mechanism allows a precise zenith alignment. The measurement uncertainty of this sensor is 5% only. The spectral response curve and the field of view (cosine type) are in near perfect accordance with the requirements defined in the ISO 17166 standard. The sensor contains integrated electronics and is shielded against electromagnetic interference. The sensor "UVI-solo" is configured with voltage output of 0 to 10V. The UV sensor is available with a PTB traceable calibration. This product bases on the UV index probe “sglux ERYCA” and enhances this probe to a ready-to-install system. Our product "Autonomous UV-Index-Transmitter" enhances the UVI-Solo to a ready-to-go system that includes a solar cell powered data trans via mobile data to a central server.

SG01L-E5

high precision SiC based UV-Index photodiode without cosine correction



GENERAL FEATURES



Properties of the SG01L-E5 UV photodiode

- ISO 17166 compliant UV-Index photodiode, uncertainty less than 5%
- Active Area A = 1.0 mm², PTB reported high chip stability
- TO5 hermetically sealed metal housing, 1 isolated pin and 1 case pin
- 1 UVI (2.5 μW/cm²) = 2.5 nA. This item needs an appropriate signal transducer transducer.
- This item needs an appropriate cosine correction to meet the Iso 17166 requirements.

Alternatively our product SG01L-E5D (including a diffuser) can be applied.

About the sglux SiC UV photodiodes

SiC provides the unique property of extreme radiation hardness, near-perfect visible blindness, low dark current, high speed and low noise. These features make SiC the best available material for visible blind semiconductor UV detectors. By standard our SiC detectors can be permanently operated at up to 170°C. A 350°C version is available. The temperature coefficient is also low, < 0.1%/K. Because of the low noise (dark current in the fA range), very low UV irradiance can be measured reliably.

Information about the UV-Index (UVI)

The UV-Index, defined by ISO 17166 standard is a measure of how dangerous the ultraviolet (UV) radiation from the sun is at a particular place on a particular day. It is a scale primarily used in daily forecasts aimed at the general public. The UV-Index is calculated by integrating the sun's UV spectrum multiplied with the Erythema action curve (see spectral response). That integral is divided by 25 mW/m² to generate a convenient index value, which becomes essentially a scale of 0 to 10. The Erythema action curve is a wavelength resolved measure of the sunburn danger. It is maximised at 297 nm (UVB) and then strongly decreases towards UVA radiation. Literature: A. F. McKinlay and B. L. Diffey, "A reference action spectrum for ultraviolet induced erythema in human skin" CIE Journal, 6-1. 17-22 (1987)

NOMENCLATURE

SG01			
S, D, L, F, XL	nothing, A, B, C, C-LED or E	18, 18ISO90, 18S, 5, 5ISO90	nothing, Lens, D
Chip area	Spectral response	Housing	Special
S 0.06 mm ²	nothing = broadband $\lambda_{\max} = 280 \text{ nm}$ $\lambda_{510\%} = 221 \text{ nm} \dots 358 \text{ nm}$	18 2-pin TO18 housing, h = 5.2 mm, 1 pin isolated, 1 pin grounded	Lens with concentrating lens, TO5 only
D 0.50 mm ²	A = UVA $\lambda_{\max} = 331 \text{ nm}$ $\lambda_{510\%} = 309 \text{ nm} \dots 367 \text{ nm}$	18ISO90 3-pin TO18 housing, h = 5.2 mm, 2 pins isolated, 1 pin grounded	
L 1.00 mm ²	B = UVB $\lambda_{\max} = 280 \text{ nm}$ $\lambda_{510\%} = 231 \text{ nm} \dots 309 \text{ nm}$	18S 2-pin TO18 housing, h = 3.7 mm, 1 pin isolated, 1 pin grounded	D with diffuser for cosine FOV
F 1.82 mm ²	C = UVC $\lambda_{\max} = 275 \text{ nm}$ $\lambda_{510\%} = 225 \text{ nm} \dots 287 \text{ nm}$	5 2-pin TO5 housing, h = 4.3 mm for broadband; h = 6.7 mm for filtered UVA, UVB, UVC, UVI	
XL 7.60 mm ²	E = UV-Index spectral response according to ISO17166	5ISO90 3-pin TO5 housing, h = 4.2 mm, 2 pins isolated, 1 pin grounded	

SG01L-E5

high precision SiC based UV-Index photodiode without cosine correction



SPECIFICATIONS

Parameter	Symbol	Value	Unit
Spectral Characteristics			
Approx. Responsivity (<i>unit is not calibrated</i>)	S_{\max}	0.10	AW^{-1}
Visible Blindness ($S_{\max}/S_{>405\text{nm}}$)	VB	$> 10^{10}$	–
General Characteristics (T=25°C)			
Active Area	A	1.0	mm^2
Dark Current (1V reverse bias)	I_d	3.3	fA
Capacitance	C	250	pF
Short Circuit (1 UVI)	I_o	2.5	nA
Temperature Coefficient	T_c	< 0.1	%/K
Maximum Ratings			
Operating Temperature	T_{opt}	-55 ... +170	°C
Storage Temperature	T_{stor}	-55 ... +170	°C
Soldering Temperature (3s)	T_{sold}	260	°C
Reverse Voltage	V_{Rmax}	20	V

NORMALIZED SPECTRAL RESPONSIVITY & ERYTHEMA ACTION CURVE

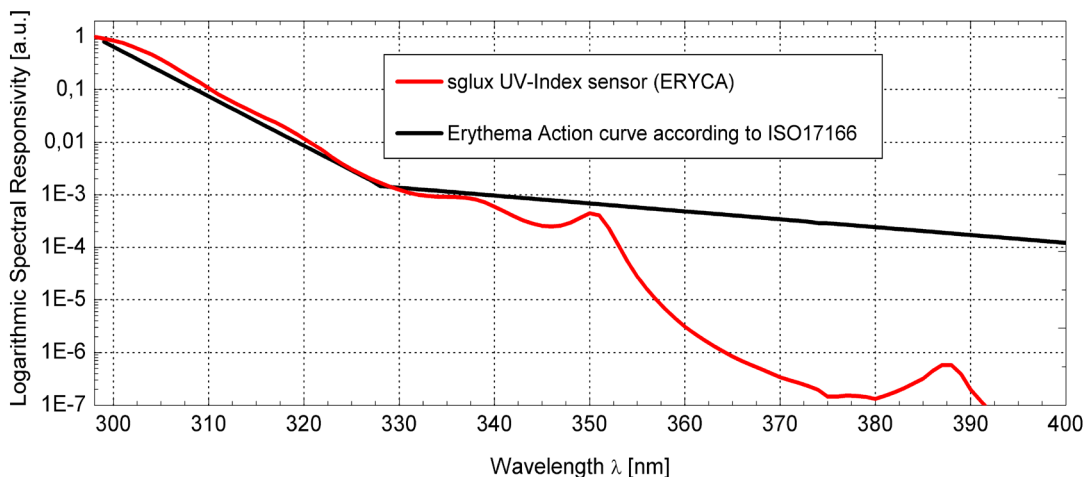

SG01L-E5

high precision SiC based UV-Index photodiode without cosine correction

FIELD OF VIEW

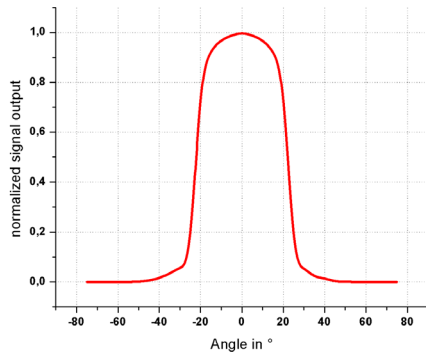

Measurement Setup

lamp aperture diameter: 10 mm
distance lamp aperture to second aperture: 17 mm
second aperture diameter: 10 mm
distance second aperture to detector: 93 mm

pivot level = top surface of the photodiode window

TYPICAL CIRCUIT

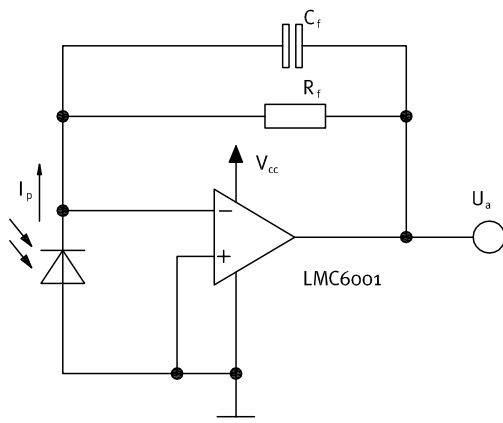

Calculations and Limits:

$$U_a = I_p \times R_f = 0 \dots \sim V_{cc}$$

$U_{a,max}$ depends on load and amplifier type

$R_f = 10k\Omega \dots \sim 10G\Omega$, $C_f \geq 3pF$
Recommendation: $R_f \times C_f \geq 10^{-3}s$

$$I_{p,max} = U_{a,max} \div R_f$$

$$\text{Bandwidth} = DC \dots \frac{1}{2\pi \times R_f \times C_f}$$

Example:

$$I_p = 20nA, R_f = 100M\Omega, C_f = 100pF$$

$$U_a = 20 \times 10^{-9}A \times 100 \times 10^6\Omega = 2V$$

DRAWINGS

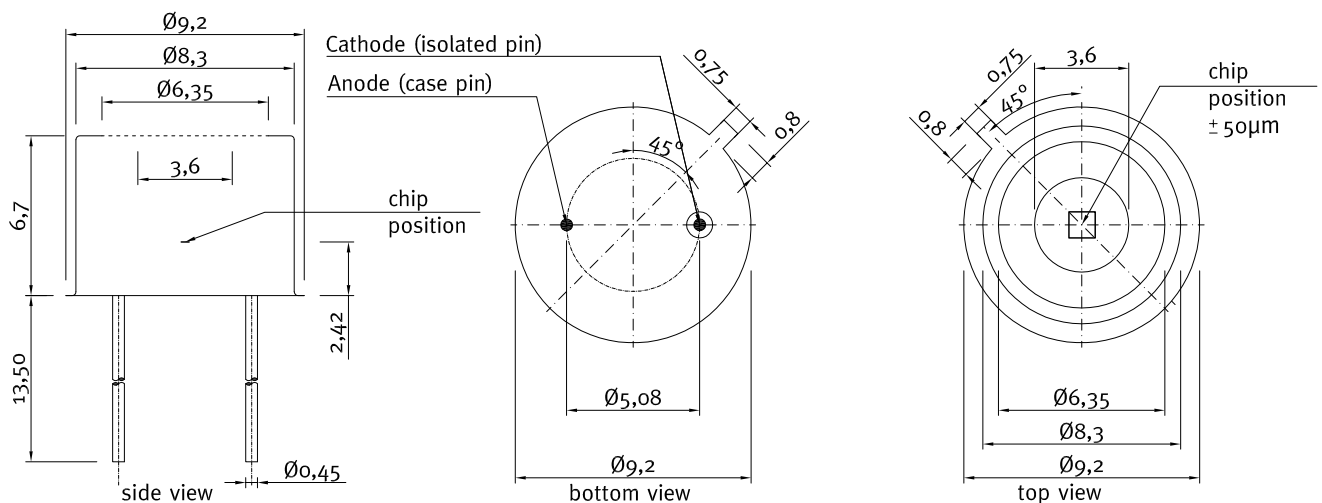

SG01L-E5

high precision SiC based UV-Index photodiode without cosine correction



APPLICATION NOTE FOR PHOTODIODES

For correct reading of the photodiode the current (and NOT the voltage) must be analyzed. This requires a short circuiting of the photodiode. Usual approaches are using a **Picoammperemeter** or a **transimpedance signal transducer** circuit as shown on page 3.

UPGRADE TO A TOCON OR A PROBE FOR UV INDEX MEASUREMENTS

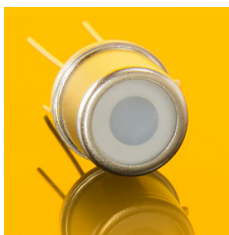

TOCONs = UV sensors with integrated signal transducer

- SiC based UV hybrid detector with signal transducer (0–5V output),
- No additional signal transducer needed, direct connection to controller, voltmeter, etc.
- With erythema filter, measures intensities up to 30 UVI



TOCON_UVI = miniature sensor probe

- UV-Index hybrid sensor (TOCON) in a PTFE housing (with G1/4" thread)
- EMC safe, with erythema filter
- Integrated sensor connector (Binder 4-Pin plug) with 2m connector cable
- Easy to mount and connect, increased EMC safety



UV-Cosine_UVI sensor probe (ERYCA)

- Special water proof and dirt-repellent housing for outdoor measurements
- Housing made of PTFE with cosine FOV, with erythema filter
- Different electronic outputs configurable (voltage, current loop, USB, Modbus, CAN)
- Good EMC safety

CALIBRATION SERVICE

Before using this photodiode a calibration is needed. Our ISO9001:2015 - certified calibration laboratory offers a PTB traceable calibration of the photodiode. Our calibration laboratory is traceable to PTB (The National Metrology Institute of Germany) and works according to guideline DAkkS-DKD-MB-3 and CIE 220:2016.

SG01L-E5D

high precision SiC based UV-Index photodiode with cosine correction



GENERAL FEATURES



Properties of the SG01L-E5D UV photodiode

- ISO 17166 compliant UV-Index photodiode, uncertainty less than 5%
- Active Area A = 1.0 mm², PTB reported high chip stability
- TO5 hermetically sealed metal housing, 1 isolated pin and 1 case pin
- 1 UVI (2.5 μW/cm²) = 2.5 nA. This item needs an appropriate signal transducer.

About the sglux SiC UV photodiodes

SiC provides the unique property of extreme radiation hardness, near-perfect visible blindness, low dark current, high speed and low noise. These features make SiC the best available material for visible blind semiconductor UV detectors. By standard our SiC detectors can be permanently operated at up to 170°C. A 350°C version is available. The temperature coefficient is also low, < 0.1%/K. Because of the low noise (dark current in the fA range), very low UV irradiance can be measured reliably. Please note that this device needs an appropriate signal transducer (see typical circuit on page 3).

Information about the UV-Index (UVI)

The UV-Index, defined by ISO 17166 standard is a measure of how dangerous the ultraviolet (UV) radiation from the sun is at a particular place on a particular day. It is a scale primarily used in daily forecasts aimed at the general public. The UV-Index is calculated by integrating the sun's UV spectrum multiplied with the Erythema action curve (see spectral response). That integral is divided by 25 mW/m² to generate a convenient index value, which becomes essentially a scale of 0 to 10. The Erythema action curve is a wavelength resolved measure of the sunburn danger. It is maximised at 297 nm (UVB) and then strongly decreases towards UVA radiation. Literature: A. F. McKinlay and B. L. Diffey, "A reference action spectrum for ultraviolet induced erythema in human skin" CIE Journal, 6-1. 17-22 (1987)

NOMENCLATURE

SG01			
S, D, L, F, XL	nothing, A, B, C, C-LED or E	18, 18ISO90, 18S, 5, 5ISO90	nothing, Lens, D
Chip area	Spectral response	Housing	Special
S 0.06 mm ²	nothing = broadband λ _{max} = 280 nm λ _{S10%} = 221 nm ... 358 nm	18 2-pin TO18 housing, h = 5.2 mm, 1 pin isolated, 1 pin grounded	Lens with concentrating lens, TO5 only
D 0.50 mm ²	A = UVA λ _{max} = 331 nm λ _{S10%} = 309 nm ... 367 nm	18ISO90 3-pin TO18 housing, h = 5.2 mm, 2 pins isolated, 1 pin grounded	
L 1.00 mm ²	B = UVB λ _{max} = 280 nm λ _{S10%} = 231 nm ... 309 nm	18S 2-pin TO18 housing, h = 3.7 mm, 1 pin isolated, 1 pin grounded	D with diffuser for cosine FOV
F 1.82 mm ²	C = UVC λ _{max} = 275 nm λ _{S10%} = 225 nm ... 287 nm	5 2-pin TO5 housing, h = 4.3 mm for broadband; h = 6.7 mm for filtered UVA, UVB, UVC, UVI	
XL 7.60 mm ²	E = UV-Index spectral response according to ISO17166	5ISO90 3-pin TO5 housing, h = 4.2 mm, 2 pins isolated, 1 pin grounded	

SG01L-E5D

high precision SiC based UV-Index photodiode with cosine correction



SPECIFICATIONS

Parameter	Symbol	Value	Unit
Spectral Characteristics			
Approx. Responsivity (<i>unit is not calibrated</i>)	S_{max}	0.10	AW^{-1}
Visible Blindness ($S_{max}/S_{>405nm}$)	VB	$> 10^{10}$	–
General Characteristics (T=25°C)			
Active Area	A	1.0	mm^2
Dark Current (1V reverse bias)	I_d	3.3	fA
Capacitance	C	250	pF
Short Circuit (1 UVI)	I_o	2.5	nA
Temperature Coefficient	T_c	< 0.1	%/K
Maximum Ratings			
Operating Temperature	T_{opt}	-55 ... +170	°C
Storage Temperature	T_{stor}	-55 ... +170	°C
Soldering Temperature (3s)	T_{sold}	260	°C
Reverse Voltage	V_{Rmax}	20	V

NORMALIZED SPECTRAL RESPONSIVITY & ERYTHEMA ACTION CURVE

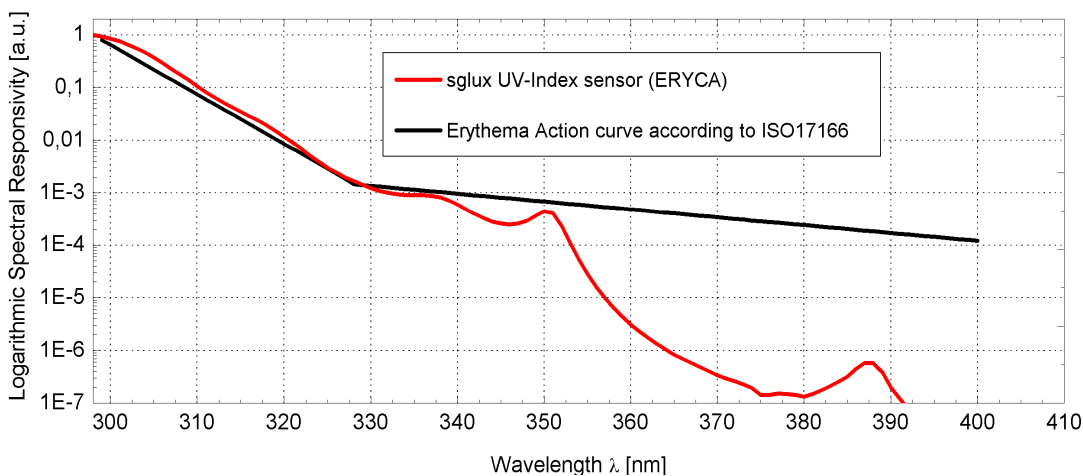

SG01L-E5D

high precision SiC based UV-Index photodiode with cosine correction



FIELD OF VIEW

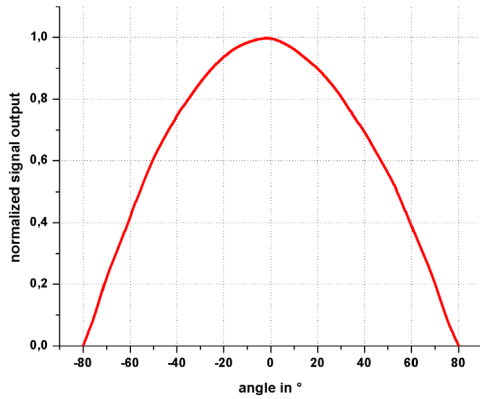

Measurement Setup

lamp aperture diameter: 10 mm
 distance lamp aperture to second aperture: 17 mm
 second aperture diameter: 10 mm
 distance second aperture to detector: 93 mm

pivot level = top surface of the photodiode window

TYPICAL CIRCUIT

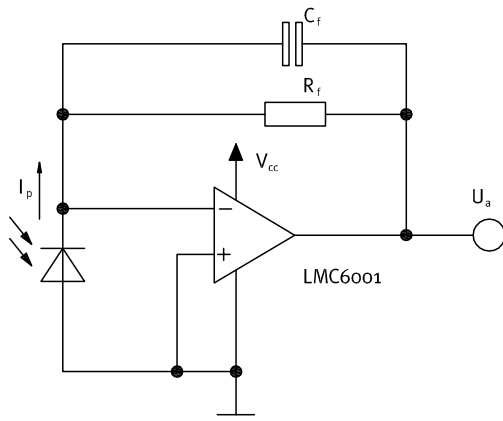

Calculations and Limits:

$$U_a = I_p \times R_f = 0 \dots \sim V_{cc}$$

$U_{a,max}$ depends on load and amplifier type

$R_f = 10k\Omega \dots \sim 10G\Omega$, $C_f \geq 3pF$
 Recommendation: $R_f \times C_f \geq 10^{-3}s$

$$I_{p,max} = U_{a,max} \div R_f$$

$$\text{Bandwidth} = DC \dots \frac{1}{2\pi \times R_f \times C_f}$$

Example:

$$I_p = 20nA, R_f = 100M\Omega, C_f = 100pF$$

$$U_a = 20 \times 10^{-9}A \times 100 \times 10^6\Omega = 2V$$

DRAWINGS

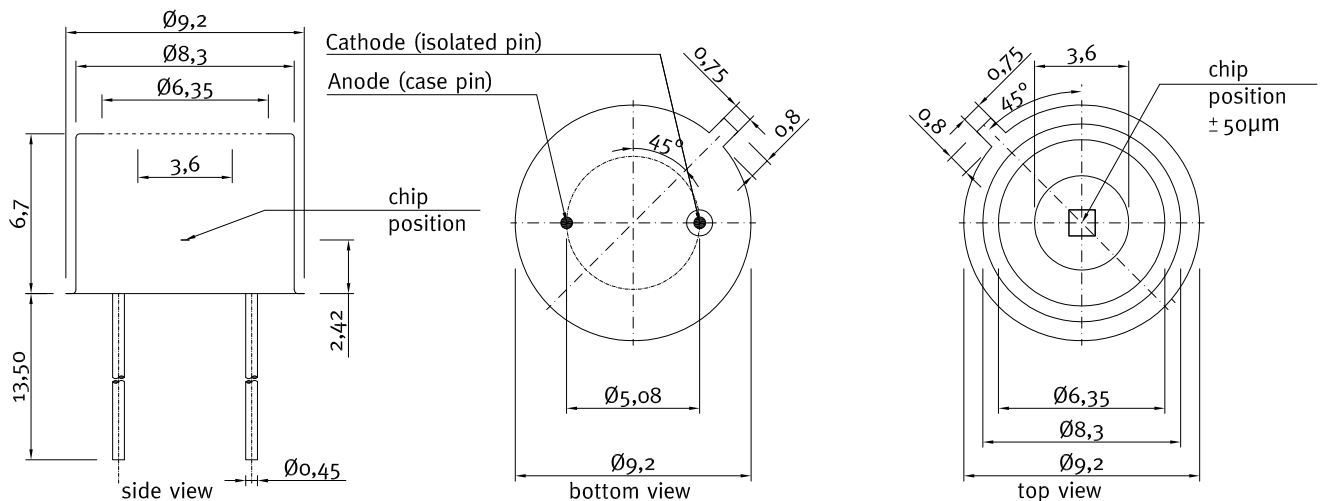

SG01L-E5D

high precision SiC based UV-Index photodiode with cosine correction



APPLICATION NOTE FOR PHOTODIODES

For correct reading of the photodiode the current (and NOT the voltage) must be analyzed. This requires a short circuiting of the photodiode. Usual approaches are using a **Picoammperemeter** or a **transimpedance signal transducer** circuit as shown on page 3.

UPGRADE TO A TOCON OR A PROBE FOR UV INDEX MEASUREMENTS



TOCONs = UV sensors with integrated signal transducer

- SiC based UV hybrid detector with signal transducer (0–5V output),
- No additional signal transducer needed, direct connection to controller, voltmeter, etc.
- With erythema filter, measures intensities up to 30 UVI



TOCON_UVI = miniature sensor probe

- UV-Index hybrid sensor (TOCON) in a PTFE housing (with G1/4" thread)
- EMC safe, with erythema filter
- Integrated sensor connector (Binder 4-Pin plug) with 2m connector cable
- Easy to mount and connect, increased EMC safety



UV-Cosine_UVI sensor probe (ERYCA)

- Special water proof and dirt-repellent housing for outdoor measurements
- Housing made of PTFE with cosine FOV, with erythema filter
- Different electronic outputs configurable (voltage, current loop, USB, Modbus, CAN)
- Good EMC safety

CALIBRATION SERVICE

Before using this photodiode a calibration is needed. Our ISO9001:2015 - certified calibration laboratory offers a PTB traceable calibration of the photodiode. Our calibration laboratory is traceable to PTB (The National Metrology Institute of Germany) and works according to guideline DAkkS-DKD-MB-3 and CIE 220:2016.

TOCON_E2

SiC based UV-Index photodetector with integrated amplifier



GENERAL FEATURES

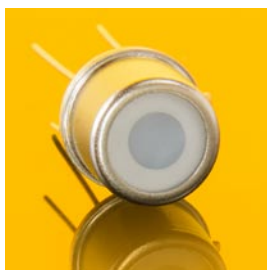

Properties of the TOCON_E2

- SiC based UV-Index photodetector in TO5 housing with diffusor
- spectral response compliant to ISO 17166
- 0...5 V voltage output
- 1 UVI results a voltage of approx. 170 mV
- Applications: UV-Index measurement with very small measurement uncertainty less than 5 %

What is a TOCON?

A TOCON is a UV photodetector with integrated amplifier converting UV radiation into a 0...5 V voltage output. The V_{out} pin of the TOCON can be directly connected to a controller, a voltmeter or any other data analyzing device with voltage input.

Information about the UV-Index (UVI)

The UV-Index is an international standard measurement of how strong the ultraviolet (UV) radiation from the sun is at a particular place on a particular day. It is a scale primarily used in daily forecasts aimed at the general public. The UV-Index is calculated by integrating the sun's UV spectrum multiplied with the Erythema action curve (see spectral responsivity). That integral is divided by 25 mW/m² to generate a convenient index value, which becomes essentially a scale of 0 to 10. The Erythema action curve is a wavelength resolved measure of the sunburn danger. It is maximised at 297 nm (UVB) and then strongly decreases towards UVA radiation.

Literature: A. F. McKinlay and B. L. Diffey, "A reference action spectrum for ultraviolet induced erythema in human skin" CIE Journal, 6-1, 17-22 (1987)

NOMENCLATURE

TOCON_	ABC, A, B, C, blue or GaP	1 ... 10
	Spectral response	Irradiance limits ($V_{supply}=5V, \lambda = \lambda_{max}$)
	ABC = broadband $\lambda_{max} = 290 \text{ nm}$ $\lambda_{S10\%} = 227 \text{ nm} \dots 360 \text{ nm}$	1 = .,8 pW/cm ² ... 18 nW/cm ²
	A = UVA $\lambda_{max} = 331 \text{ nm}$ $\lambda_{S10\%} = 309 \text{ nm} \dots 367 \text{ nm}$	2 = 18 pW/cm ² ... 180 nW/cm ²
	B = UVB $\lambda_{max} = 280 \text{ nm}$ $\lambda_{S10\%} = 243 \text{ nm} \dots 303 \text{ nm}$	3 = 180 pW/cm ² ... 1.8 μW/cm ²
	C = UVC $\lambda_{max} = 275 \text{ nm}$ $\lambda_{S10\%} = 225 \text{ nm} \dots 287 \text{ nm}$	4 = 1.8 nW/cm ² ... 18 μW/cm ²
	Blue = blue light $\lambda_{max} = 445 \text{ nm}$ $\lambda_{S10\%} = 390 \text{ nm} \dots 515 \text{ nm}$	5 = 18 nW/cm ² ... 180 μW/cm ²
	GaP = UV + VIS $\lambda_{max} = 445 \text{ nm}$ $\lambda_{S10\%} = 190 \text{ nm} \dots 570 \text{ nm}$	6 = 180 nW/cm ² ... 1.8 mW/cm ²
	E = UV-Index spectral response according to ISO 17166	7 = 1.8 μW/cm ² ... 18 mW/cm ²
		8 = 18 μW/cm ² ... 180 mW/cm ²
		9 = 180 μW/cm ² ... 1.8 W/cm ²
		10 = 1.8 mW/cm ² ... 18 W/cm ²
		2 = measurement range UVI up to 30

TOCON_E2

SiC based UV-Index photodetector with integrated amplifier



SPECIFICATIONS

Parameter	Symbol	Value	Unit
Spectral Characteristics			
Approx. Sensitivity (<i>UNIT IS NOT CALIBRATED</i>)	S_{max}	170	mV/UVI
Visible Blindness ($S_{max}/S_{>405nm}$)	VB	$> 10^{10}$	-
General Characteristics (T=25°C, V_{supply} = +5 V)			
Supply Voltage range	V _{Supply}	2.5 ... 5	V
Saturation Voltage	V _{Sat}	V _{Supply} - 5%	V
Typical dark output voltage at 10 MOhm load	V _{Offset}	700	μV
Typical temperature Coefficient at Peak	T _c	< +-0.3	%/K
Typical Current Consumption	I	35	μA
Bandwidth (-3 dB)	B	15	Hz
Risetime (10-90%)	t _{rise}	0.182	s
<i>(SHORTER RISETIME AND BANDWIDTH ON REQUEST)</i>			
Maximum Ratings			
Operating Temperature	T _{opt}	-25 ... +85	°C
Storage Temperature	T _{stor}	-40 ... +100	°C
Maximum soldering temperature (for 3 seconds)	T _{sold}	300	°C

NORMALIZED SPECTRAL RESPONSIVITY

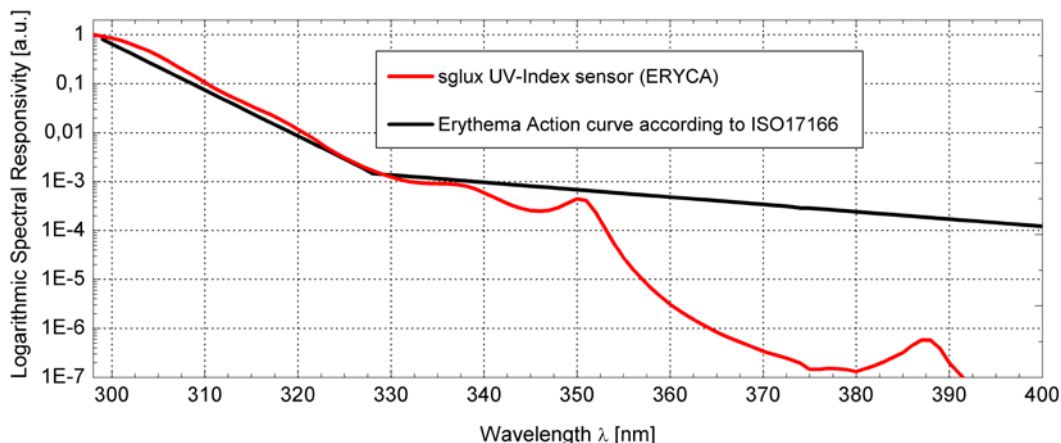

TOCON_E2

SiC based UV-Index photodetector with integrated amplifier



FIELD OF VIEW

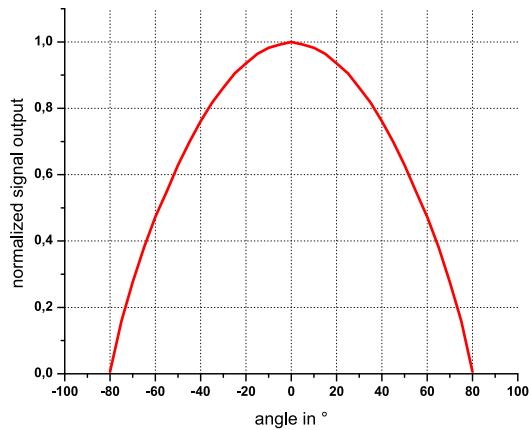

Measurement Setup:

- lamp aperture diameter: 10 mm
- distance lamp aperture to second aperture: 17 mm
- second aperture diameter: 10 mm
- distance second aperture to detector: 93 mm

pivot level = top surface of the detector window

DRAWING

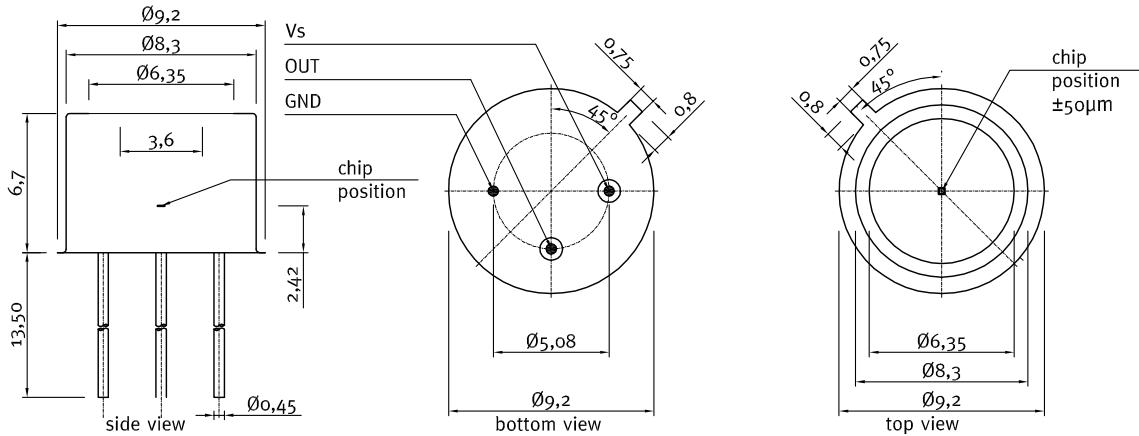

TOCON_E2

SiC based UV-Index photodetector with integrated amplifier



APPLICATION NOTE FOR TOCONS

The TOCONS need a supply voltage of $V_{\text{supply}} = 2.5 \dots 5 V_{\text{DC}}$ and can be directly connected to a controller or voltmeter. Please note that the theoretic maximum signal output is always a little less (approx. 5 %) than the supply voltage. To learn more about perfect use of the TOCONS please refer to the TOCON FAQ list published at www.sglux.com.

CAUTION! Wrong wiring leads to destruction of the device.

For easy setup of the device please ask for a TOCON starter kit.



Miniature steel housing with M12x1 thread for the TOCON series

- Optional feature for all TOCON detectors
- Robust stainless steel M12x1 thread body, length 32 mm
- Integrated sensor connector (Binder 4-Pin plug) with 2 m connector cable
- Easy to mount and to connect



Miniature PTFE housing with M12x1 thread for the TOCON series

- Optional feature for all TOCON detectors without concentrator lens
- Teflon (PTFE) M12x1 thread body, length 31 mm
- Wide field of view, dirt-repellant, water proof at wet side (IP 68)
- Integrated sensor connector (Binder 4-Pin plug) with 2 m connector cable
- Easy to mount and connect, cleanable

The PTFE housing reduces the signal output by approx. 95%. Please consider this while selecting the TOCON's sensitivity range.



Plastic probes

- Optional feature for all TOCON detectors
- UV probes in small plastic housings with a TOCON inside
- Customized housings available
- Easy to mount and to connect
- Integrated sensor connector (Binder 4-Pin plug)
- Cable available



Water pressure proof TOCON housing

- Optional feature for all TOCON detectors without concentrator lens
- G1/4" thread, 10 bar water pressure proof
- Customized housings available
- Easy to mount and to connect
- Integrated sensor connector (Binder 5-Pin plug)
- Cable available

TOCON_E_OEM

SiC based UV-Index photodetector with integrated amplifier designed to work with customer's cosine correcting dome



GENERAL FEATURES



Properties of the TOCON_E_OEM

- SiC based UV-Index photodetector in TO5 housing
- spectral response compliant to ISO 17166
- **designed to work with customer's cosine correcting dome**
- 0...5 V voltage output
- 1 UVI results a voltage of approx. 0.5 V
- Applications: UV-Index measurement with very small measurement uncertainty less than 5 %

What is a TOCON?

A TOCON is a UV photodetector with integrated amplifier converting UV radiation into a 0...5 V voltage output. The V_{out} pin of the TOCON can be directly connected to a controller, a voltmeter or any other data analyzing device with voltage input.

Information about the UV-Index (UVI)

The UV-Index is an international standard measurement of how strong the ultraviolet (UV) radiation from the sun is at a particular place on a particular day. It is a scale primarily used in daily forecasts aimed at the general public. The UV-Index is calculated by integrating the sun's UV spectrum multiplied with the Erythema action curve (see spectral responsivity). That integral is divided by 25 mW/m² to generate a convenient index value, which becomes essentially a scale of 0 to 10. The Erythema action curve is a wavelength resolved measure of the sunburn danger. It is maximised at 297 nm (UVB) and then strongly decreases towards UVA radiation.

Literature: A. F. McKinlay and B. L. Diffey, "A reference action spectrum for ultraviolet induced erythema in human skin" CIE Journal, 6-1, 17-22 (1987)

NOMENCLATURE

TOCON_	ABC, A, B, C, blue or GaP	1 ... 10
	Spectral response	Irradiance limits ($V_{supply}=5V, \lambda = \lambda_{max}$)
	ABC = broadband $\lambda_{max} = 290 \text{ nm}$ $\lambda_{S10\%} = 227 \text{ nm} \dots 360 \text{ nm}$	1 = 1.8 pW/cm ² ... 18 nW/cm ²
	A = UVA $\lambda_{max} = 331 \text{ nm}$ $\lambda_{S10\%} = 309 \text{ nm} \dots 367 \text{ nm}$	2 = 18 pW/cm ² ... 180 nW/cm ²
	B = UVB $\lambda_{max} = 280 \text{ nm}$ $\lambda_{S10\%} = 243 \text{ nm} \dots 303 \text{ nm}$	3 = 180 pW/cm ² ... 1.8 μW/cm ²
	C = UVC $\lambda_{max} = 275 \text{ nm}$ $\lambda_{S10\%} = 225 \text{ nm} \dots 287 \text{ nm}$	4 = 1.8 nW/cm ² ... 18 μW/cm ²
	Blue = blue light $\lambda_{max} = 445 \text{ nm}$ $\lambda_{S10\%} = 390 \text{ nm} \dots 515 \text{ nm}$	5 = 18 nW/cm ² ... 180 μW/cm ²
	GaP = UV + VIS $\lambda_{max} = 445 \text{ nm}$ $\lambda_{S10\%} = 190 \text{ nm} \dots 570 \text{ nm}$	6 = 180 nW/cm ² ... 1.8 mW/cm ²
	E = UV-Index spectral response according to ISO 17166	7 = 1.8 μW/cm ² ... 18 mW/cm ²
		8 = 18 μW/cm ² ... 180 mW/cm ²
		9 = 180 μW/cm ² ... 1.8 W/cm ²
		10 = 1.8 mW/cm ² ... 18 W/cm ²
		2 = measurement range UVI up to 30

TOCON_E_OEM

SiC based UV-Index photodetector with integrated amplifier
designed to work with customer's cosine correcting dome



SPECIFICATIONS

Parameter	Symbol	Value	Unit
Spectral Characteristics			
Approx. Sensitivity (<i>UNIT IS NOT CALIBRATED</i>)	S_{max}	0.5	V/UVI
Visible Blindness ($S_{max}/S_{>405nm}$)	VB	$> 10^{10}$	-
General Characteristics (T=25°C, V_{supply}=+5 V)			
Supply Voltage range	V _{Supply}	2.5 ... 5	V
Saturation Voltage	V _{Sat}	V _{Supply} - 5%	V
Typical dark output voltage at 10 MOhm load	V _{Offset}	50	μV
Typical temperature Coefficient at Peak	T _c	< +0.3	%/K
Typical Current Consumption	I	35	μA
Bandwidth (-3 dB)	B	15	Hz
Risetime (10-90%)	t _{rise}	0.182	s
<i>(SHORTER RISETIME AND BANDWIDTH ON REQUEST)</i>			
Maximum Ratings			
Operating Temperature	T _{opt}	-25 ... +85	°C
Storage Temperature	T _{stor}	-40 ... +100	°C
Maximum soldering temperature (for 3 seconds)	T _{sold}	300	°C

NORMALIZED SPECTRAL RESPONSIVITY

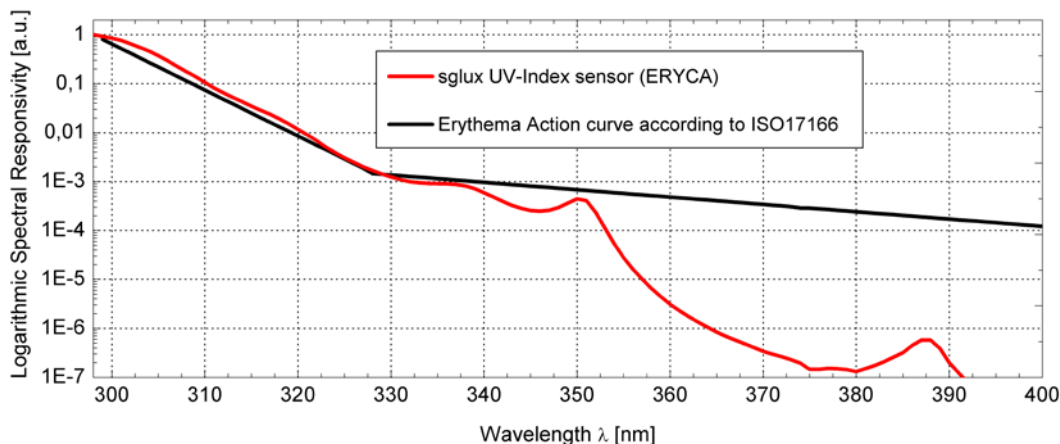

TOCON_E_OEM

SiC based UV-Index photodetector with integrated amplifier
designed to work with customer's cosine correcting dome



FIELD OF VIEW

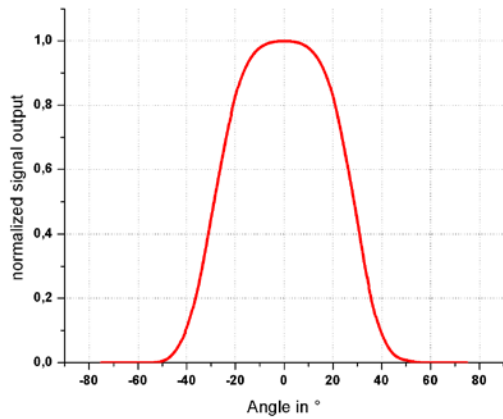

Measurement Setup:

- lamp aperture diameter: 10 mm
- distance lamp aperture to second aperture: 17 mm
- second aperture diameter: 10 mm
- distance second aperture to detector: 93 mm

pivot level = top surface of the detector window

DRAWING

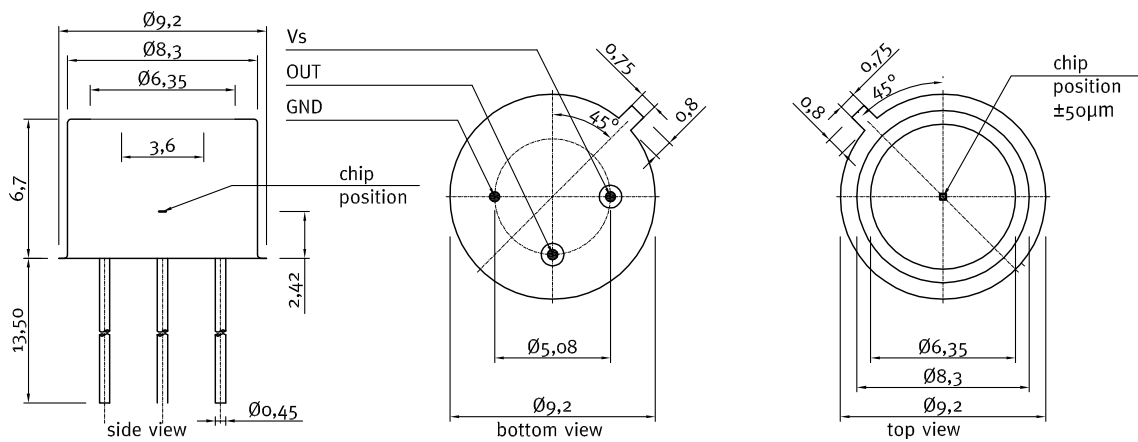

TOCON_E_OEM

SiC based UV-Index photodetector with integrated amplifier designed to work with customer's cosine correcting dome



APPLICATION NOTE FOR TOCONs

The TOCONs need a supply voltage of $V_{\text{supply}} = 2.5 \dots 5 V_{\text{DC}}$ and can be directly connected to a controller or voltmeter. Please note that the theoretic maximum signal output is always a little less (approx. 5 %) than the supply voltage. To learn more about perfect use of the TOCONs please refer to the TOCON FAQ list published at www.sglux.com.

CAUTION! Wrong wiring leads to destruction of the device.

For easy setup of the device please ask for a TOCON starter kit.

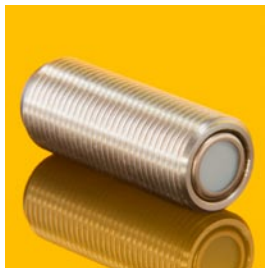

Miniature steel housing with M12x1 thread for the TOCON series

- Optional feature for all TOCON detectors
- Robust stainless steel M12x1 thread body, length 32 mm
- Integrated sensor connector (Binder 4-Pin plug) with 2 m connector cable
- Easy to mount and to connect



Miniature PTFE housing with M12x1 thread for the TOCON series

- Optional feature for all TOCON detectors without concentrator lens
- Teflon (PTFE) M12x1 thread body, length 31 mm
- Wide field of view, dirt-repellant, water proof at wet side (IP 68)
- Integrated sensor connector (Binder 4-Pin plug) with 2 m connector cable
- Easy to mount and connect, cleanable

The PTFE housing reduces the signal output by approx. 95 %. Please consider this while selecting the TOCON's sensitivity range.



Plastic probes

- Optional feature for all TOCON detectors
- UV probes in small plastic housings with a TOCON inside
- Customized housings available
- Easy to mount and to connect
- Integrated sensor connector (Binder 4-Pin plug)
- Cable available



Water pressure proof TOCON housing

- Optional feature for all TOCON detectors without concentrator lens
- G1/4" thread, 10 bar water pressure proof
- Customized housings available
- Easy to mount and to connect
- Integrated sensor connector (Binder 5-Pin plug)
- Cable available

TOCON_UVI

UV-Index sensor with G1/4" Thread and Plug Connector

GENERAL FEATURES



Properties of the TOCON_UVI

This UV sensor is designed for very high accuracy UV-Index measurements. The measurement uncertainty of this sensor is 5% only. The spectral response curve and the field of view (cosine type) are in near perfect accordance with the requirements defined in the ISO 17166 standard. The sensor contains integrated electronics and is shielded against electromagnetic interference. The sensor housing is made of Teflon (PTFE), water pressure proof up to 10 bar and configured with a G1/4" thread. The supply voltage is 7 to 24 V (low power option 2.5 to 5 V available on request) and the signal output is 0 to 5 V. This sensor is delivered with integrated sensor connector

(Binder 5-Pin plug) and 2 m cable. The UV sensor is available with a PTB traceable calibration.

The PTFE housing reduces the signal output by 90 - 99 %.

SPECIFICATIONS

Parameter	Symbol	Value	Unit
Spectral Characteristics			
Approx. Sensitivity (<i>UNIT IS NOT CALIBRATED</i>)	S_{max}	170	mV/UVI
Visible Blindness ($S_{max}/S_{>405nm}$)	VB	$> 10^{10}$	–
General Characteristics (T=25°C, V_{supply}=+7 V)			
Supply Voltage	V _{Supply}	7 to 24	V
Max. Output Voltage (non depending on V _{supply})	V _{Out}	4.75	V
Temperature Coefficient at Peak for SiC	T _c	-0.3	%/K
Current Consumption	I	150	µA
Maximum Ratings			
Operating Temperature	T _{opt}	-25 to +85	°C
Storage Temperature	T _{stor}	-40 to +100	°C

TOCON_UVI

UV-Index sensor with G1/4" Thread and Plug Connector



NORMALIZED SPECTRAL RESPONSIVITY

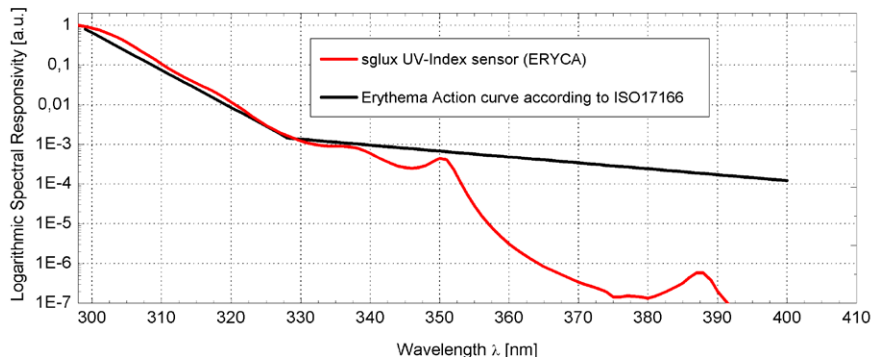

FIELD OF VIEW

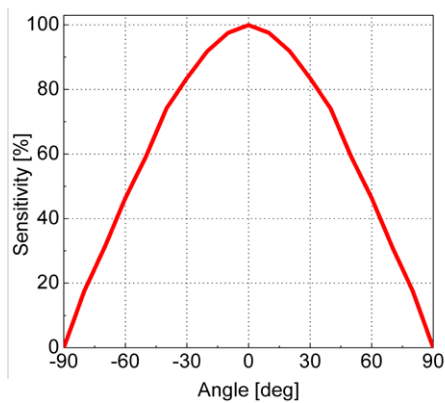

Measurement Setup:

- lamp aperture diameter: 10 mm
- distance lamp aperture to second aperture: 17 mm
- second aperture diameter: 10 mm
- distance second aperture to detector: 93 mm

pivot level = top surface of the detector window

DRAWING

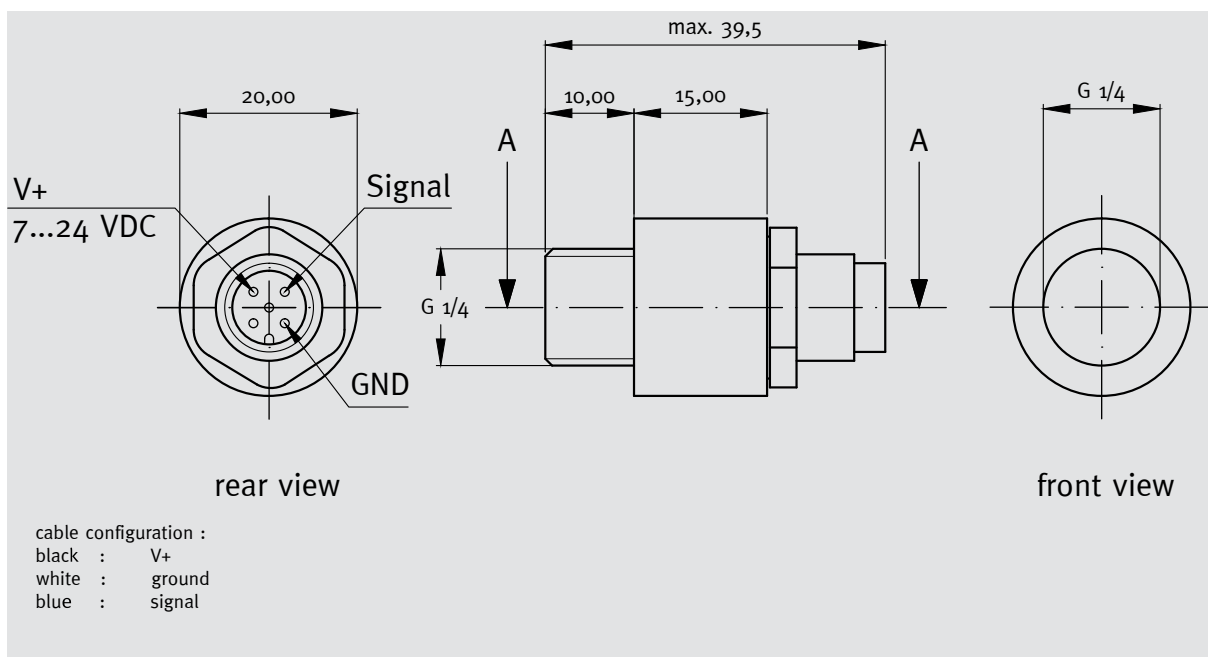

Products for UV-Index measurements



PHOTODIODES AND SENSORS (MEASUREMENT UNCERTAINTY < 5%)

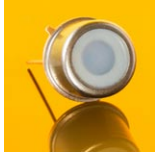

SiC UV photodiodes

UV-Index photodiodes, different active chip areas and housings, with erythema filter



SiC TOCONs

UV-Index hybrid sensor in a TO5 housing with 0 - 5 V signal output, with erythema filter

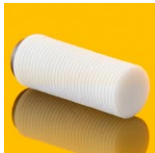

TOCON_PTFE24V_UVI

UV-Index hybrid sensor (TOCON) in PTFE housing (male thread M12x1), EMC safe, with erythema filter



TOCON_UVI

UV-Index hybrid sensor (TOCON) in PTFE housing (with G1/4" thread), EMC safe, with erythema filter



UV-Surface_UVI

top looking surface-mount UV sensor probe with cosine FOV, EMC safe, with erythema filter



UV-Cosine_UVI

waterproof UV-Index sensor probe with cosine FOV, EMC safe, for outdoor use, with erythema filter

UV-INDEX DISPLAYS AND NETWORK COMPUTERS



UV-Index reference radiometer

Reference radiometer for UV-Index measurements, incl. calibrated (PTB traceable) UVI sensor probe



Skylink UV transmitter

network computer with UV-Index sensor

UV Sensor "UV-Surface_UVI"



Top looking surface-mount UV sensor for UV-Index measurements



GENERAL FEATURES



The "UV-Surface_UVI" is designed for high accuracy UV-Index measurements. The measurement uncertainty of this sensor is 5% only. The spectral responsivity and the field of view are in near perfect accordance with the requirements defined in the ISO 17166 standard. It is featured by a cosine shaped field of view and is often used with the sglux Radiometer SXL 55 (see page 5). The signal output type can be configured as a voltage output of 0 to 5 V or a current of 4 to 20 mA. Digital output sensors are available with a MOD bus, a CAN bus or a USB interface. A magnetic sensor holder is available as accessory (see page 5). The UV sensor is available with a PTB traceable calibration.

For customers that like to purchase a ready-to-install system to monitor the UV-Index we produce the "UVI-Solo" and the "stand alone UV Index transmitter". The UVI-Solo is a waterproof pole or railings mounted UV-Index sensor. The integrated leveling mechanism allows a precise zenith alignment. The solar cell powered stand-alone UV Index transmitter measures the UV Index and transmits the values via cellular radio using the MQTT protocol to a server where the obtained values are stored. By default this server is hosted by sglux (ThingsBoard open IoT). Alternatively the user's server can be used. The unit does not require any wiring to the building where it is placed. It can also be used where lightning protection requirements exclude wires on the roof of a building. For further information please refer to the related datasheets at www.sglux.com.

SPECTRAL RESPONSIVITY

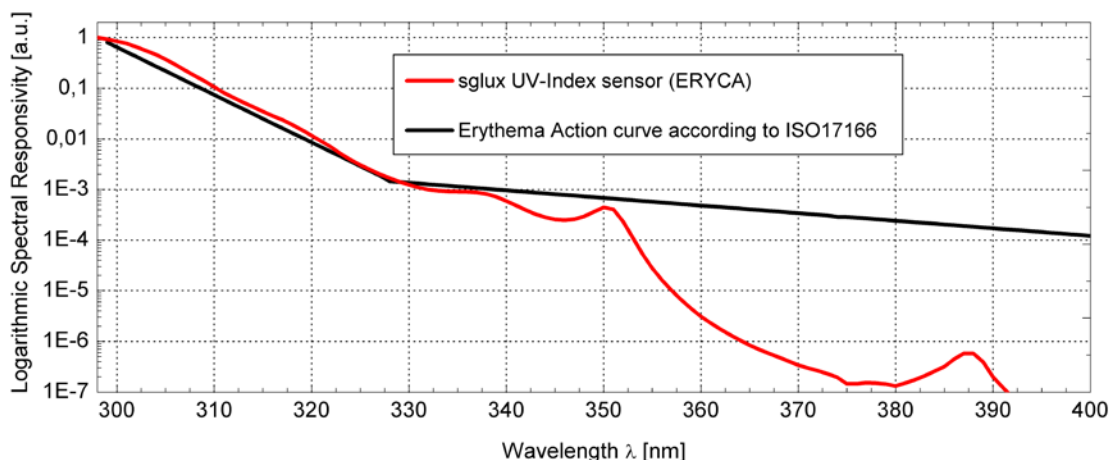

Figure 1: Spectral responsivity of the sglux ERYCA compared with the Erythema action curve as defined by ISO 17166

UV Sensor "UV-Surface_UVI"

Top looking surface-mount UV sensor for UV-Index measurements



GENERAL SPECIFICATIONS

<i>FIXED SPECIFICATIONS</i>	Parameter	Value
	Dimensions	Please refer to drawing on page 4.
	Field of view	Please refer to graph on page 4.
	Weight	27 g
	Temperature coefficient (30 to 65°C)	0.05 to 0.075%/K
	Operating temperature	-20 to +80°C
	Storage temperature	-40 to +80°C
	Humidity	< 80%, non condensing
	Time constant	0.1s +/-20% - other time constants on request, device has 1st order low pass characteristics
	Spectral responsivity	UV-Index as defined by ISO 17166
	Measurement range	UVI 0 ... 30
	IP protection class	60

SIGNAL OUTPUT SPECIFICATIONS

Signal output 0 to 5 V	0 to 5 V output proportional to the irradiance
Supply voltage	7.5 to 24 VDC
Current consumption	< 30 mA
Connections	2 m cable version: V ₋ =brown, V ₊ =white, V _{out} =green, shield=black plug version: not available
Dark offset voltage	< 3 mV
Measurement range	UVI 0 ... 30

UV Sensor "UV-Surface_UVI"

Top looking surface-mount UV sensor for UV-Index measurements



Signal output 4 to 20 mA	4 to 20 mA current loop for PLC controllers - The current is proportional to the irradiance.
Supply voltage	24 VDC +/-10% (down to 12 V possible if compliance voltage and loop resistance is considered)
Current consumption	=signal out
Connections	cable version: I _{OUT} =brown, V ₊ =white, shield=black 2 m cable length, other lengths available (max. 20m) plug version: not available
Measurement range	UVI 0 ... 30
Sensor compliance voltage	8.5 V
Max. loop resistance	645 Ohm @ 24V and 145 Ohm @12V
Offset	4 mA +/- 0.01 mA

Signal output USB	USB output with USB-A (to computer) or μ USB connector (to smartphone)
Supply voltage	5 V (USB powered)
Current consumption	< 17 mA
Connections	USB2.0-A connector (to computer, free software "UVPLOT" is available) or USB2.0-micro-B connector (to a smartphone device like the Radiometer SXL55) 2 m cable length.
Measurement range	UVI 0 ... 30

Signal output CAN bus	CAN Bus with VSCP protocol for integration into a bus system or to be used with the sglux UVTOUCH or the sglux Digibox.
Supply voltage, current consumption	5 to 24 V +/- 10%
Connections	8-pin M16 x 0.75 connector: Pins 1&7 = CAN low, Pins 3&8 = CAN high, Pin 6=V+, Pins 2&4&5 = GND, 2 m cable length, other lengths available
Measurement range	4 orders of magnitude
Available displays and converters	UVTOUCH and Digibox

UV Sensor "UV-Surface_UVI"

Top looking surface-mount UV sensor for UV-Index measurements



FIELD OF VIEW

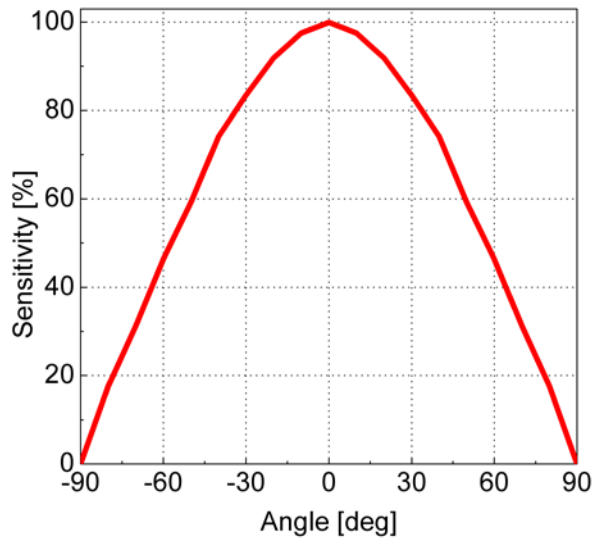

DRAWING (values in mm)

ANALOG CABLE

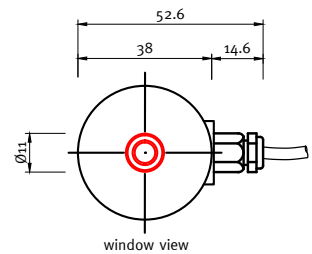
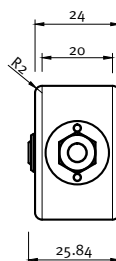
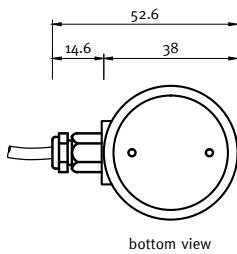

DIGITAL

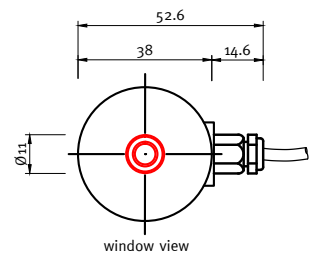
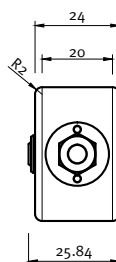
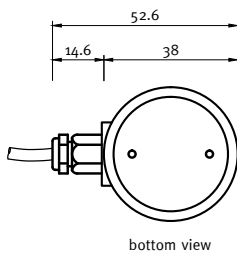

CAN

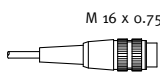

KFV 8o plug



pin layout

USB



USB Type A



Micro USB

UV Sensor "UV-Surface_UVI"

Top looking surface-mount UV sensor for UV-Index measurements



SENSOR HOLDER AVAILABLE AS OPTIONAL ACCESSORY

The below pictures show a useful accessory for the UV-Surface sensor. This sensor holder is featured by a magnetic foot that allows to attach the sensor on every steel surface, also at a ceiling. The sensor and the holder are also connected by a magnet. The bottom of the holder has a 1/4" 20 UNC threaded hole to be connected to a standard camera tripod.

The holder allows various usages with one sensor. The sensor can be attached at a defined fixed position but also can be removed from this position to measure the UV radiation at another place. Additionally, the holder can be used as a protective cap when flipped.

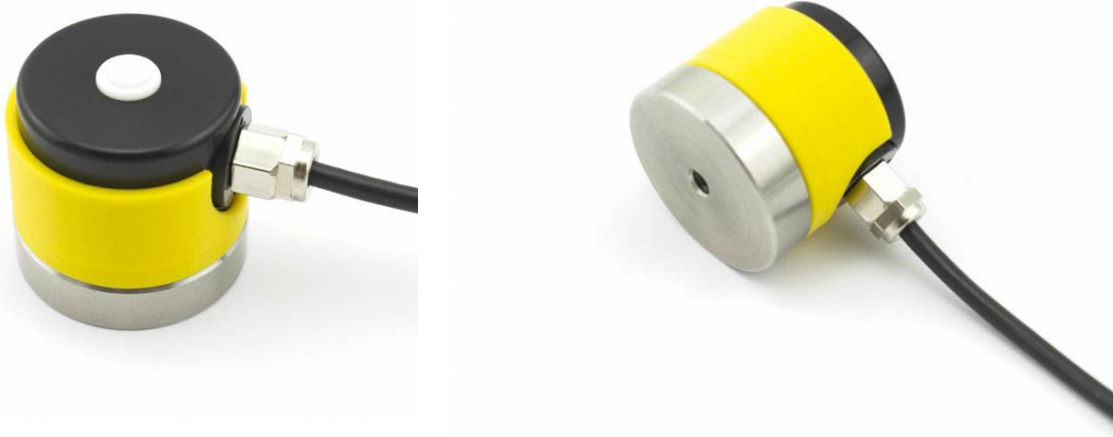

DISPLAY UNIT AVAILABLE AS OPTIONAL ACCESSORY

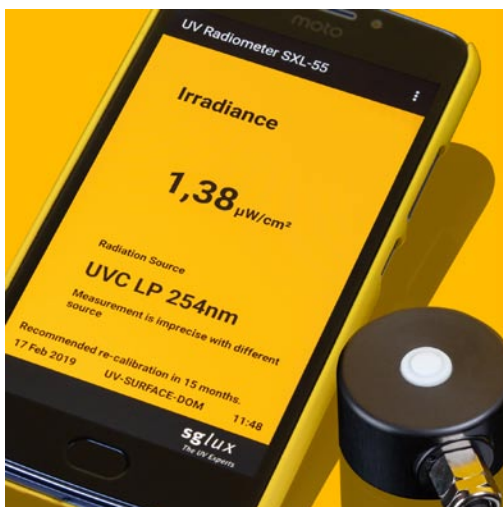

The UV Radiometer SXL 55 is a smartphone based useful accessory to display the UV-Surface sensor probe measurement values and to execute dose or dosimeter measurement.

For detailed information please refer to the SXL 55 datasheet available on our webpage.

Sensor Probes Overview



LABORATORY & EXPERIMENTS



UV-Surface

Universal radiometric UV sensor for calibration and reference measurements, cosine correction. Often used with radiometer SXL55.



UV-Cosine

Waterproof dirt repellent UV sensor for outdoor measurement, cosine field of view. Also available as UVI sensor (ERYCA), M20x1.5 thread.

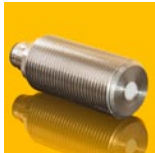

UV-Air

Axial measuring screw-in UV sensor very good EMC properties, M22x1.5 thread.



TOCON-Probe

Miniature UV sensor with 0 to 5 V voltage output, M12x1 thread.

SPECIAL APPLICATIONS



UV-Arc

Waterproof UV sensor for measurement of electric arcs between overhead contact wires and pantograph, complies with EN 50317, G3/4" thread.



sglux ERYCA

High accuracy UV-Index sensor, measurement uncertainty is <5%. The sensor complies with ISO 17166, M20x1.5 thread.



UVI-Solo

Like sglux ERYCA but configured as a ready-to-mount system (available for pole or railings assembly).



uvLink One

Wireless UV sensor with a display unit for intensity and dose measurement.

DUTY SENSORS MONITORING

UV DISINFECTION OF AIR, SURFACES AND WATER



UV-Sanitize

UV sensor for monitoring of air and surface UV disinfection systems, configurable for monitoring of Hg low pressure lamps, excimer lamps or xenon flash lamps, M20x1.5 thread.



UV-Water-G3/4

UV sensor for operation in pressurized water (10 bar), for Hg medium and low pressure lamps.



UV-Water-PTFE

PTFE UV sensor for operation in pressurized water (10 bar), only for Hg low pressure lamps or LEDs, G1/4" thread.



UV-ÖNORM / UV-DVGW

UV sensor for DVGW(160°) and ÖNORM certified water purifiers, also available as UV-DVGW (40°). The sensors comply with ÖNORM M5873, DVGW W294(06), DIN19294



UV-Radial

Waterproof side looking UV sensor for monitoring of lamp bundles, for operation in a cladding tube or directly in water, M20x1.5 thread.

HIGH UV RADIATION



UV-Cure

UV sensor for high irradiance (>100mW/cm²) for LED curing or cooled medium pressure lamps, M22x1.5 thread (temperature sensor available).

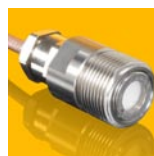

UV-Cure_HT

Like UV-Cure but for temperatures up to 170°C, e.g. for uncooled medium pressure systems, M22x1.5 thread.

UV Sensor "sglux ERYCA"

Waterproof cosine corrected UV sensor for UV-Index measurements



GENERAL FEATURES



This UV sensor, also called "**UV-Cosine_UVI**", is designed for high accuracy UV-Index measurements. The measurement uncertainty of this sensor is 5% only. The spectral responsivity and the field of view (cosine type) are in near perfect accordance with the requirements defined in the ISO 17166 standard. The housing is made of PTFE. It is waterproof and stain repellent with a male threaded body (M20x1.5). The sensor contains integrated electronics and is shielded against electromagnetic interference. The sensor's output can be configured as a voltage of 0 to 5 V or a current of 4 to 20 mA. Digital output sensors are available with a MOD bus, a CAN bus or a USB interface. The UV sensor is available with a PTB traceable calibration.

For customers that like to purchase a ready-to-install system to monitor the UV-Index we produce the "UVI-Solo" and the "stand alone UV Index transmitter". The UVI-Solo is a waterproof pole or railings mounted UV-Index sensor. The integrated leveling mechanism allows a precise zenith alignment. UVI-Solo's measurement function bases on the sglux ERYCA. The solar cell powered stand-alone UV Index transmitter measures the UV Index and transmits the values via cellular radio using the MQTT protocol to a server where the obtained values are stored. By default this server is hosted by sglux (ThingsBoard open IoT). Alternatively the user's server can be used. The unit does not require any wiring to the building where it is placed. It can also be used where lightning protection requirements exclude wires on the roof of a building. The unit also bases on the UV sensor "sglux ERYCA". For further information please refer to the related datasheets at www.sglux.com.

SPECTRAL RESPONSIVITY

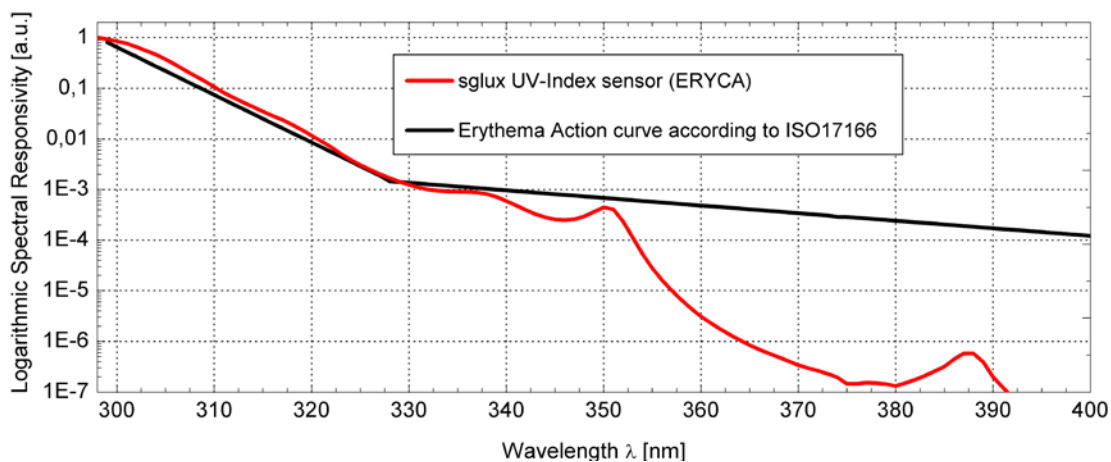

Figure 1: spectral responsivity of the sglux ERYCA compared with the Erythema action curve as defined by ISO 17166

UV Sensor "sglux ERYCA"

Waterproof cosine corrected UV sensor for UV-Index measurements



GENERAL SPECIFICATIONS

<i>FIXED SPECIFICATIONS</i>	Parameter	Value
	Dimensions	Please refer to drawing on page 4.
	Field of view	Please refer to graph on page 4.
	Weight	27 g
	Temperature coefficient (30 to 65°C)	0.05 to 0.075%/K
	Operating temperature	-20 to +80°C
	Storage temperature	-40 to +80°C
	Humidity	< 80%, non condensing
	Time constant	0.1s +/-20% - other time constants on request, device has 1st order low pass characteristics
	Spectral responsivity	UV-Index as defined by ISO 17166
	Measurement range	UVI 0 ... 30

SIGNAL OUTPUT SPECIFICATIONS

Signal Output 0 to 5 V or 0 to 10V	0 to 5V or 0 to 10V voltage output proportional to the irradiance
Supply voltage	7.5 to 24 VDC (0 to 5V output) and 12 to 24 VDC (0 to 10V)
Current consumption	< 30mA
Connections	2m cable version: V-=brown, V+=white, V _{OUT} =green, shield=black cable version is not available for 0 to 10V voltage output plug version 0-5V: GND=1(brown), V+=4(black), V _{OUT} =3(blue) plug version 0-10V: GND = 2(white), V+=4(black), V _{OUT} =1(brown)
Dark offset voltage	< 3 mV
Measurement range	UVI 0 ... 30

UV Sensor "sglux ERYCA"

Waterproof cosine corrected UV sensor for UV-Index measurements



Signal Output 4 to 20 mA	4 to 20mA current loop for PLC controllers - The current is proportional to the irradiance.
Supply voltage	24 VDC +/-10% (down to 12V possible if compliance voltage and loop resistance is considered)
Current consumption	=signal out
Connections	cable version: IOUT=brown, V+=white, shield=black 2 m cable length, other lengths available (max.20 m) plug version: IOUT=1(brown), V+=4(black)
Measurement range	UVI 0 ... 30
Sensor compliance voltage	8.5 V
Max. loop resistance	645 Ohm @ 24V and 145 Ohm @12V
offset	4 mA +/- 0.01 mA
Signal Output USB	USB output with USB-A (to computer) or μ USB connector (to smartphone)
Supply voltage	5V (USB powered)
Current consumption	< 17 mA
Connections	USB2.0-A connector (to computer, free software "UVPLOT" is available) or USB2.0-micro-B connector (to a smartphone device like the Radiometer SXL55) 2m cable length.
Measurement range	UVI 0 ... 30
Signal Output CAN bus	CAN Bus with VSCP protocol for integration into a bus system or to be used with the sglux UVTOUCH or the sglux Digibox
Supply voltage, current consumption	5 to 24 V +/- 10%
Connections	8-pin M16 x 0.75 connector: Pins 1&7 = CAN low, Pins 3&8 = CAN high, Pin 6=V+, Pins 2&4&5 = GND, 2m cable length, other lengths available
Measurement range	4 orders of magnitude
Available displays and converters	UVTOUCH and Digibox
Signal Output MOD bus	MOD bus RTU over RS-485 (connection parameters programmable)
Supply voltage, current consumption	5 to 24V +/-10%, typ. 20mA, max. 25mA
Connections	5-pin M12 connector at sensor side and Binder cable M12-A Series 763 with open wires, Shield =1 (shield), V+ = 2 (red), GND = 3 (black), B = 4 (white), A = 5 (blue)

UV Sensor "sglux ERYCA"

Waterproof cosine corrected UV sensor for UV-Index measurements



FIELD OF VIEW

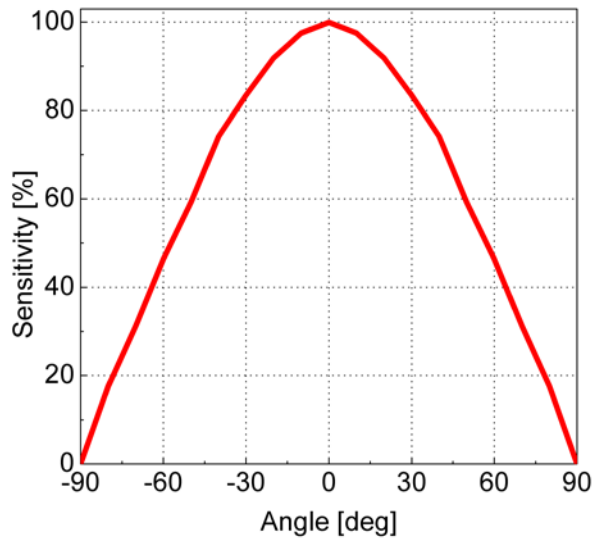

DRAWING (values in mm)

ANALOG CABLE

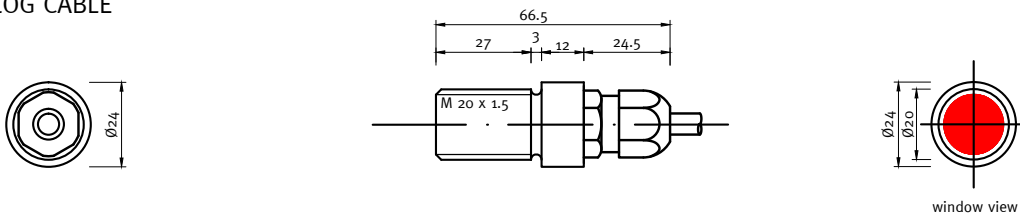

ANALOG PLUG

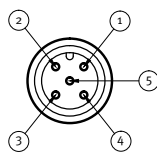
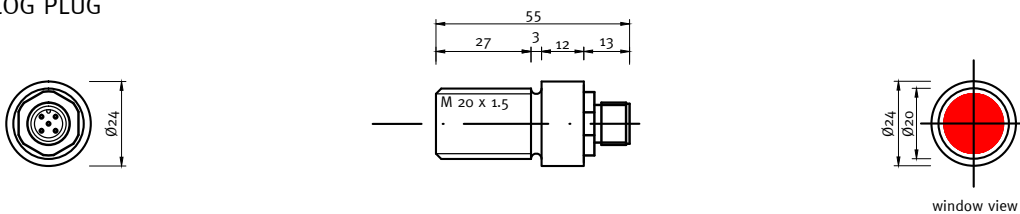

connector view
5 pin M 12 x 1
RSFM5

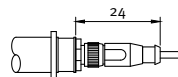

plug connection
5 pin M 12 x 1
e.g. Lumberg PRSFM 5

DIGITAL

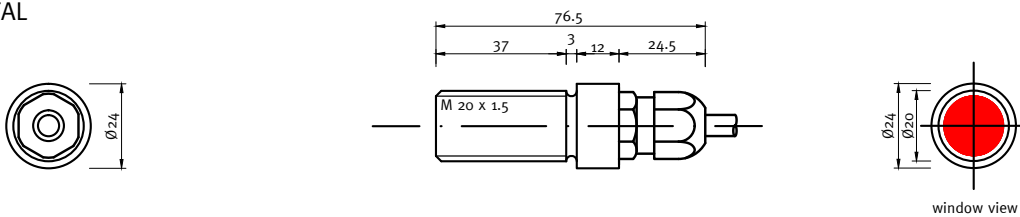

CAN



USB



Sensor Probes Overview



LABORATORY & EXPERIMENTS



UV-Surface

Universal radiometric UV sensor for calibration and reference measurements, cosine correction. Often used with radiometer SXL55.



UV-Cosine

Waterproof dirt repellent UV sensor for outdoor measurement, cosine field of view. Also available as UVI sensor (ERYCA), M20x1.5 thread.

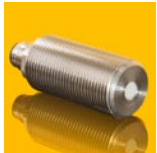

UV-Air

Axial measuring screw-in UV sensor very good EMC properties, M22x1.5 thread.



TOCON-Probe

Miniature UV sensor with 0 to 5 V voltage output, M12x1 thread.

SPECIAL APPLICATIONS



UV-Arc

Waterproof UV sensor for measurement of electric arcs between overhead contact wires and pantograph, complies with EN 50317, G3/4" thread.



sglux ERYCA

high accuracy UV-Index sensor, measurement uncertainty is < 5%. The sensor complies with ISO 17166, M20x1.5 thread.



UVI-Solo

like sglux ERYCA but configured as a ready-to-mount system (available for pole or railings assembly).



UV-Wireless

wireless UV sensor with a display unit for intensity and dose measurement.

DUTY SENSORS MONITORING

UV DISINFECTION OF AIR, SURFACES AND WATER



UV-Sanitize

UV sensor for monitoring of air and surface UV disinfection systems, configurable for monitoring of Hg low pressure lamps, excimer lamps or xenon flash lamps, M20x1.5 thread.



UV-Water-G3/4

UV sensor for operation in pressurized water (10 bar), for Hg medium and low pressure lamps.



UV-Water-PTFE

PTFE UV sensor for operation in pressurized water (10 bar), only for Hg low pressure lamps or LEDs, G1/4" thread.



UV-ÖNORM / UV-DVGW

UV sensor for DVGW(160°) and ÖNORM certified water purifiers, also available as UV-DVGW (40°). The sensors comply with ÖNORM M5873, DVGW W294(06), DIN19294



UV-Radial

Waterproof side looking UV sensor for monitoring of lamp bundles, for operation in a cladding tube or directly in water, M20x1.5 thread.

HIGH UV RADIATION



UV-Cure

UV sensor for high irradiance (>100mW/cm²) for LED curing or cooled medium pressure lamps, M22x1.5 thread (temperature sensor available).

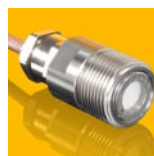

UV-Cure_HT

Like UV-Cure but for temperatures up to 170°C, e.g. for uncooled medium pressure systems, M22x1.5 thread.

Safester UVI

Radiometer for risk assessment of solar UV radiation according to ISO 17166



PROPERTIES OF THE SAFESTER UVI

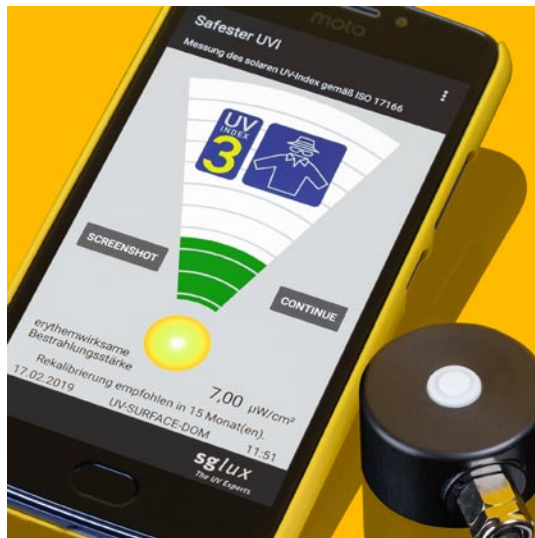

The Safester UVI is used for the risk assessment of solar UV radiation. The device determines the UV index defined by the WHO [1] according to ISO 17166 [2]. It displays the weighted, erythema-effective radiation in $\mu\text{W}/\text{cm}^2$ as well as the UV index calculated from this according to the standard. Pictograms recommend adapted protective measures according to the WHO recommendation depending on the UV index. The Safester UVI consists of a calibrated sglux sensor of the type „UV-Surface_UVI“ and a smartphone with corresponding software. The input optics of the sensor unit consists of a cosine corrected diffuser that detects radiation from the entire upper sky half-space. The core of the sensor is a silicon carbide (SiC) semiconductor diode.

SiC semiconductor diodes are sensitive only to radiation components from the UV range and not from the visible or infrared spectral range, which together account for more than 95 % of total solar radiation. The diode is preceded by an optical filter with optimal adaptation to erythema action curve [3]. Radiation components that do not contribute to the UV index are suppressed. The interaction of the optical components results in the UV index as the measured value. The measurement uncertainty of the Safester UVI is less than $\pm 6 \%$ for UVI values smaller than 8 and less than $\pm 3 \%$ for UVI values larger than 8 [4,5]. The technical data for the sensor „UV-Surface_UVI“ can be found from page 3 of this data sheet.

SETUP, FUNCTIONS AND MAINTENANCE OF THE SAFESTER UVI

Connect the sensor to the USB input of the smartphone and switch on the smartphone. The app for measuring and displaying the measured values starts automatically. The display of the continuously measured UVI can be paused using the hold button. The screenshot function saves the currently visible information as a photo in the device.

Despite its robust design, the Safester UVI is a sensitive measuring instrument. The sensor should especially be protected from falls and its entry window should be kept clean. Depending on the intensity of use, recalibration is recommended every 2-3 years. This can be done in our calibration laboratory.

Safester UVI

Radiometer for risk assessment of solar UV radiation according to ISO 17166



▶ HOW TO DO A MEASUREMENT

For UV index measurements, the Safester UVI is usually operated in a location where the sensor is not affected by shading from trees or buildings or reflections from reflective surfaces. An ideal location is an elevated place where the entire horizon is freely visible. Here the sensor is aligned horizontally and the measurement is carried out. According to standard's requirements, the sensor must not be aligned to the sun. It is also possible to use the device under the shade of trees, e.g. to determine the UV index in parks, or to use it under sunshades to measure the protective effect.

▶ ABOUT THE UV-INDEX

The Safester UVI shows the UV index in numbers and with colored background on the display. The colors correspond to the specifications of the WHO, which gives the following recommendations for action for the various measured values [1]:

UV-Index 1-2	low UV-Index	No protection needed. You can safely stay outside.
UV-Index 3-5	moderate UV-Index	Wear a shirt and a hat and use sunscreen.
UV-Index 6-7	high UV-Index	Seek shade during late morning though mid-afternoon. When outside, generously apply broad-spectrum SPF-15 or higher sunscreen on exposed skin, wear protective clothing, a wide-brimmed hat, and sunglasses.
UV-Index 8-10	very high UV-Index	Extra protection is needed. If your shadow is shorter than you, seek shade and wear protective clothing, a wide-brimmed hat, and sunglasses, generously apply broad-spectrum SPF-15 or higher sunscreen on exposed skin.
UV-Index 11	extreme UV-Index	Avoid being outside.

The UVI displayed is the current measured value, which changes when measurements are taken over the course of the day. The displayed recommendation for action applies to the respective time of measurement. In contrast, UVI predictions indicate the daily maximum value.

It is recommended to carry out several measurements daily, even at the sun's peak, in order to be able to take the appropriate protective measures in each case.

Safester UVI

Radiometer for risk assessment of solar UV radiation according to ISO 17166



SPECIFICATIONS

Function	Broadband radiometer for the determination of the UV-Index
Properties	Battery powered radiometer consisting of a UV-Index sensor (SiC-photodiode with filter according to the Erythema action curve) and a smartphone
Measuring range	Wavelength: 290 nm ... 390 nm UV-Index: 0 ... 25 = erythemal irradiation intensity: 0 ... 625 mW/m ²
Input optics	cosine corrected diffusor with 11 mm diameter
Photodiode	SiC photodiode with filter
Calibration	PTB traceable calibration
Measurement uncertainty	<= UVI 2 ± 12%, >UVI 2: ± 6%, >UVI 8: ± 3%
Interface	USB 2.0
Temperature range	-5°C ... +45°C
Power supply	from smartphone via USB
Weight	260 g (sensor and smartphone)

SPECTRAL RESPONSIVITY OF THE SENSOR "UV-SURFACE_UVI (ERYCA)"

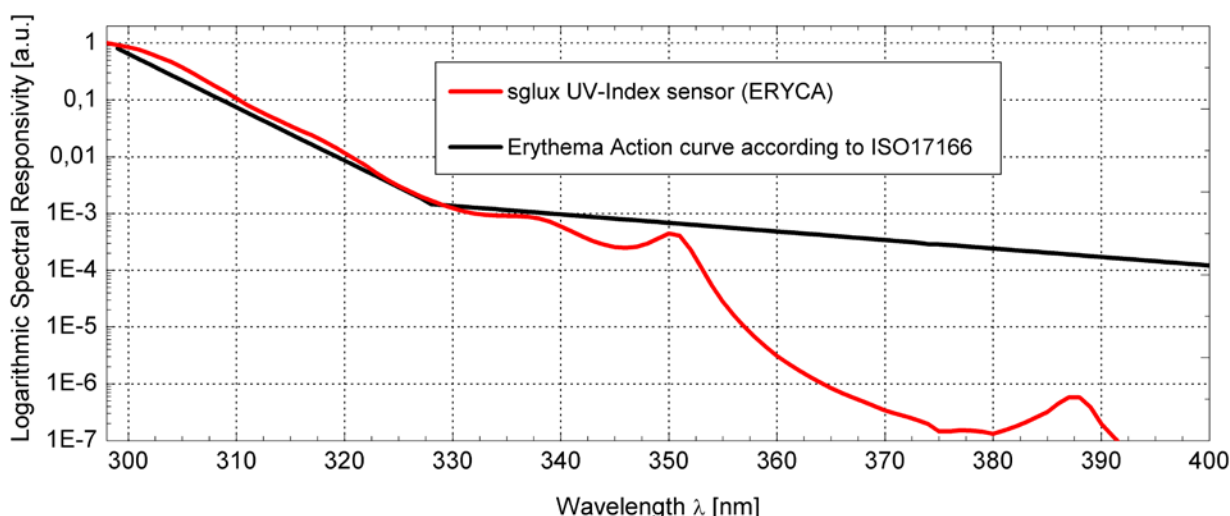

Safester UVI

Radiometer for risk assessment of solar UV radiation according to ISO 17166



FIELD OF VIEW OF THE SENSOR "UV-SURFACE_UVI (ERYCA)"

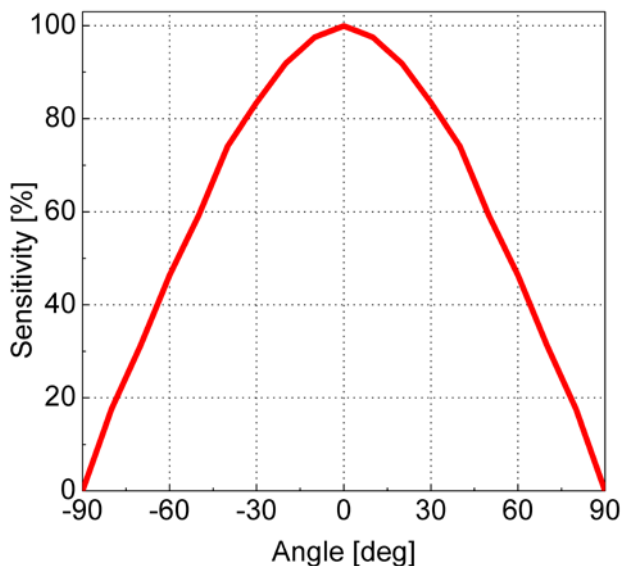

LITERATURE

1. WHO: Global solar UV index - A Practical Guide, <https://www.who.int/uv/publications/en/UVIGuide.pdf>
2. ISO 17166:1999(en), <https://www.iso.org/obp/ui/#iso:std:iso:17166:ed-1:v2:en>
3. McKinlay AF, Diffey BL, A reference action spectrum for ultraviolet induced erythema in human skin. *CIE J* 1987; 6: 17-22.
4. A.W. Schmalwieser, J. Gröbner, M. Blumthaler, B. Klotz, H. De Backer, D. Bolsée, R. Werner, D. Tomsic, L. Metelka, P. Eriksen, N. Jepsen, M. Aun, A. Heikkilä, T. Duprat, H. Sandmann, T. Weiss, A. Bais, Z. Toth, A. M. Siani, L. Vaccaro, H. Diémoz, D. Grifoni, G. Zipoli, G. Lorenzetto, B. H. Petkov, A. Giorgio di Sarra, F. Massen, C. Yousif, A.A. Aculinin, P. den Outer, T. Svendby, A. Dahlback, B. Johnsen, J. Bieszczuk-Jakubowska, J. Krzyscin, D. Henriques, N. Chubarova, P. Kolarz, Z. Mijatovic, D. Groselj, A. Pribulova, J. Ramon Moreta Gonzales, J. Bilbao, J. M. Vilaplana Guerrero, A. Serrano, S. Andersson, L. Vuilleumier, A. Webb and J. O'Hagan (2017) UV Index monitoring in Europe. *Photochem. Photobiol. Sci.*, 16, 1349-1370, DOI 10.1039/C7PP00178A
5. Dae-Hwan Park, Seung-Taek Oh, and Jae-Hyun Lim: Development of a UV Index Sensor-Based Portable Measurement Device with the EUVB Ratio of Natural Light, *Sensors* 2019, 19(4), 754; doi:10.3390/s19040754

AUTONOMOUS UV-INDEX-TRANSMITTER



- Measurement and calculation of the UV index
- Data transfer via mobile data to a central server, no ongoing costs
- Data collection in a database
- Autonomous energy supply via solar power and storage battery
- Different options to display the measured data
- Installation and use do not require IT skills

▶ PRODUCT DESCRIPTION

The autonomous UV-Index-Transmitter registers the current erythemally effective UV radiation (UV index) according to ISO 17166:2019 as well as the technical WHO requirements and sends the measured data via mobile data to a central database operated by sglux. Alternatively, the measured values/the measurement signal can also be sent exclusively or additionally to a database of the user. Due to the autonomous energy provision, the UV-Index-Transmitter can also be installed on top of buildings where power or data cables may not be installed because of external lightning and surge protection. This product bases on the UV index probe “sglux ERYCA” and enhances this probe to a ready-to-go system. Our product “UVI Solo” offers an alternative by combining the “sglux ERYCA” with a USB output as well as a pole or railing bracket ready for installation.

▶ USERS OF THE AUTONOMOUS UV-INDEX TRANSMITTER

The UV-Index-Transmitter is mainly operated by public institutions such as municipalities, schools or recreational facilities. The two pictures below (courtesy of BfS) show the device in operation for the German Federal Office for Radiation Protection (BfS). Shown are the measuring stations in Berlin and in Grömnitz. They are part of the nationwide solar UV measurement network operated by BfS, which is mainly equipped with UV sensors from sglux.



AUTONOMOUS UV-INDEX-TRANSMITTER



SPECIFICATIONS

Sensor	SiC-based UVI sensor with interference filter (“sglux ERYCA”, see image 1 for spectral sensitivity) acc. to ISO 17166:2019 and WHO requirements.
Measurement uncertainty	+/-10%
Measuring range	0.00 to 0.75 W/m ² erythemally effective UV radiation, equal to UVI 0 to 30
Field of view	Cosine-weighted dome made from PTFE
Calibration	towards the sun, PTB traceable
Resolution	2 mW/m ² , equal to UVI 0.08
Temperature range	-30°C to 70°C
Energy supply	10 W solar module with storage battery, 7-day run time in constant shade (e.g. snow). Longer battery run time possible on request.
Transferred data points	erythemally effective UV radiation in W/m ² via MQTT protocol, battery voltage, charge current, charge status, internal temperature. More data points (e.g. external temperature, humidity) possible on request.
Radio connection	via mobile data, SIM card and data pass permanently included in purchase price. No additional mobile data costs.
Weight	3.4 kg
Product measurements	deliverable for mounting on poles or railings, see drawing on page 3

AUTONOMOUS UV-INDEX-TRANSMITTER

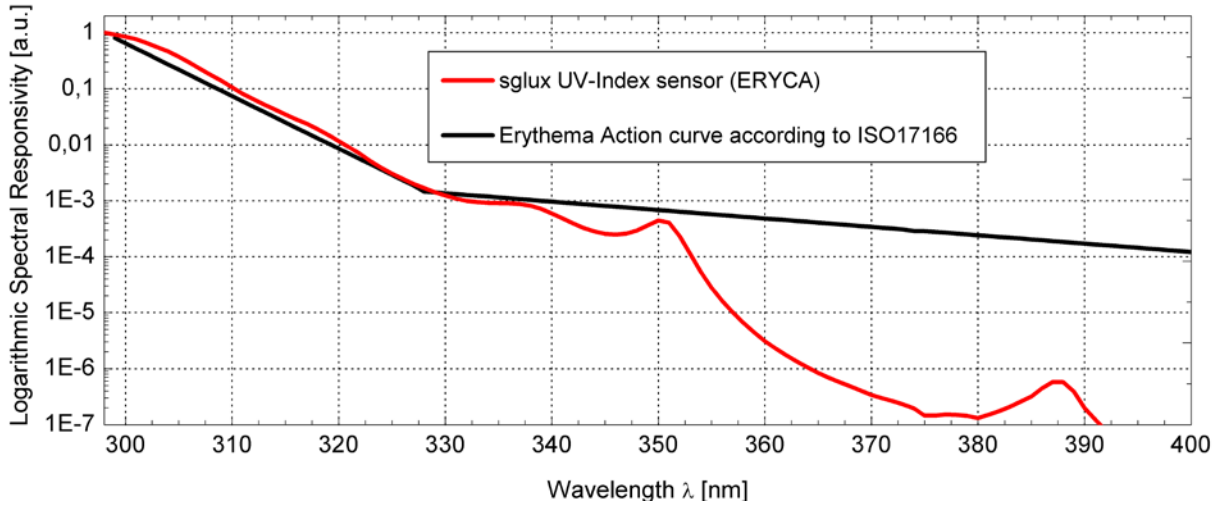

Image 1 Spectral sensitivity of a “sglux ERYCA” sensor compared to the erythemal effectiveness function acc. to ISO 17116:2019

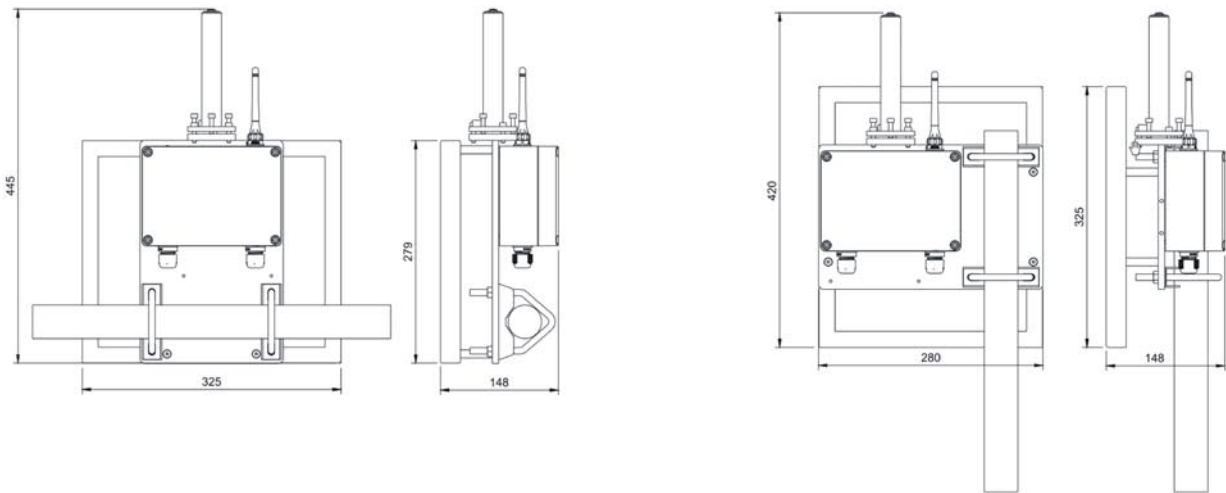

Image 2 Product measurements, arrangement for horizontal (railing) mount) on the left; arrangement for vertical (mast) mount on the right (as in product image on page 1)

AUTONOMOUS UV-INDEX-TRANSMITTER



INSTALLATION

Ensure direct orientation of the solar cell towards south as much as possible when installing the device, so that the sensor is not blocked by the shade of trees or buildings throughout the day. Exceptions for measurements targeted specifically at discovering the UV radiation in the shade of trees or buildings (e.g. parks, schools or day care facilities). In this case, the device should be mounted at eye level with people who are moving in the designated area.

Check with a spirit level before installation whether the mast is properly vertical (or the railing properly horizontal).

Mount the device to the mast (or railing, depending on your arrangement) with the help of the supplied bracket set.

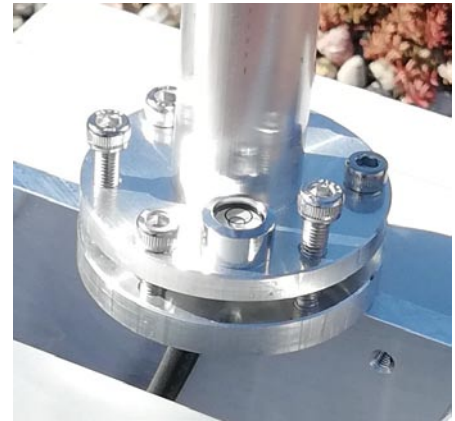

Image 3 Adjustment unit

To perform the measurements conforming to ISO 17166 standards, the UV sensor has to be oriented exactly vertically to the zenith. Image 3 shows the spirit level and the hex adjusting screws intended for the exact orientation.

Should the proper orientation not be possible with the adjustment unit, the mast or railing are not vertical or horizontal enough for installation. In such case, the mast or railing should first be oriented properly.

If not possible due to the building construction, we are able to deliver needed offset pieces upon request.

INITIAL SETUP

There are no switches, electrical connections or display units on the device by intention. Once the solar cell has charged the battery sufficiently, the UVI-Transmitter is going to measure and transfer the values autonomously. With a cloudless, sunny sky in summer, charging an at-first fully discharged battery takes approximately one hour after installation. Unfavorable weather conditions prolong the waiting time proportionately before measurements and transfers can start.

The device is delivered with a PTB-traceable calibration and a calibration certificate. Due to the sensor components' exceptional resistance against radiation, a recalibration is only needed every 3 years.

The dismounting of the device is unnecessary, as we will send a reference radiometer for recalibration as a loan. Our technical support team walks the user through the small number of easy steps for recalibration. The device itself is maintenance-free, as the sensor is enclosed by dirt-repellent Teflon and mounted on a mast at a 24 cm height. This prevents damage to the sensor by birds (pecking, droppings).

The sensor height also prevents distortion of the measurement caused by snow up to a height of 24 cm.

Nonetheless, the device should be checked every now and again in the first months to ensure proper operation. Check-ups are especially necessary when the measured data widely deviates from the predicted value on cloudless days. Checking the position of the bubble on the spirit level will determine whether the sensor is still oriented vertically in the correct way. The solar cells and the sensor should be kept free from dirt and shade at all times.

AUTONOMOUS UV-INDEX-TRANSMITTER



▶ DISPLAY OF MEASUREMENTS

Our thorough technical support is included in the price of the UV-Index-Transmitter, to ensure the implementation of the measurements into the individual customer's display setup. We are available without a time limit for your questions or any problems that may arise later.

RECALIBRATION AND CARE

The reasons for operating a UVI measuring station varies, and the respective varying uses determine the different requirements for the measurement displays. Scientists may use the data base values to operate their own analysis and publication (for which meteorological and data base knowledge is required on the customer side). However, for users without specific prior knowledge, we also offer simple “plug & play” solutions, which are included in the product price, consisting of a web-based desktop view as shown in image 4. This displays the current UV index according to WHO requirements and shows the UVI history for the current and the previous day. Layout and text on this page serve as an example which may be configured to the individual user needs.

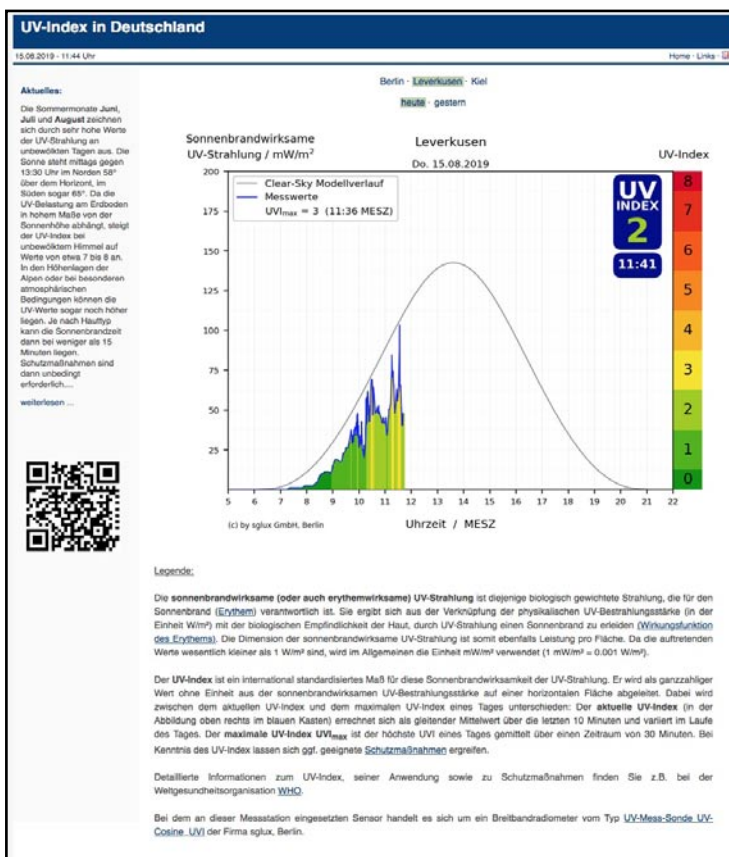

Other possible layouts may include a web display optimized for smartphones, a smartphone application, or a display optimized for wall-mounted monitors. For construction sites or outdoor pools, we suggest a display unit with mechanical indicators, as opposed to electronic displays, to ensure visibility of the measurements in bright sunlight. sglux is looking forward to implement solutions together with you that fit your specific needs. There is no need for prior meteorological or database knowledge.

Image 4 Example of the display of UV index variation. Color coding and UV index calculation acc. to WHO requirements

UV Sensor "UVI-Solo"

Pole or railings mounted UV sensor for UV-Index measurements



GENERAL FEATURES

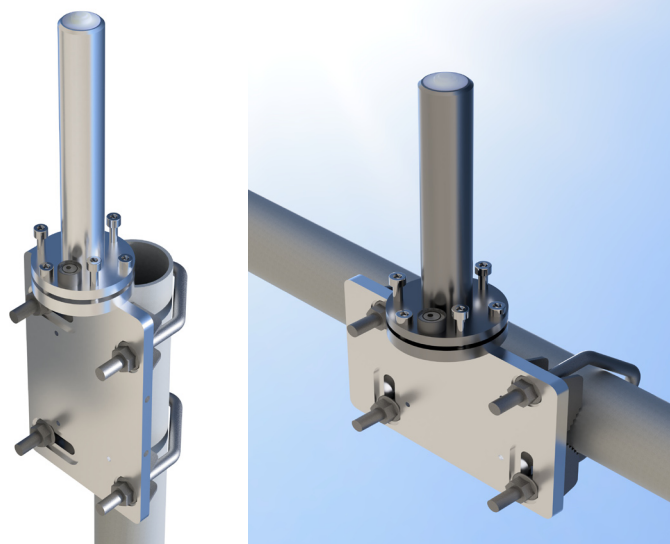

The UVI-Solo is a waterproof pole or railings mounted high accuracy UV-Index sensor. The integrated leveling mechanism allows a precise zenith alignment. The measurement uncertainty of this sensor is 5% only. The spectral responsivity and the field of view (cosine type) are in near perfect accordance with the requirements defined in the ISO 17166 standard. The sensor contains integrated electronics and is shielded against electromagnetic interference. This product bases on the UV index probe "sglux ERYCA" and enhances this probe to a ready-to-install system.

Our product "Autonomous UV-Index-Transmitter" enhances the UVI-Solo to a ready-to-go system that includes a solar cell powered data transfer via mobile data to a central server. The sensor "UVI-Solo" is configured with voltage output of 0 to 10 V. The UV sensor is available with a PTB traceable calibration.

SPECTRAL RESPONSIVITY

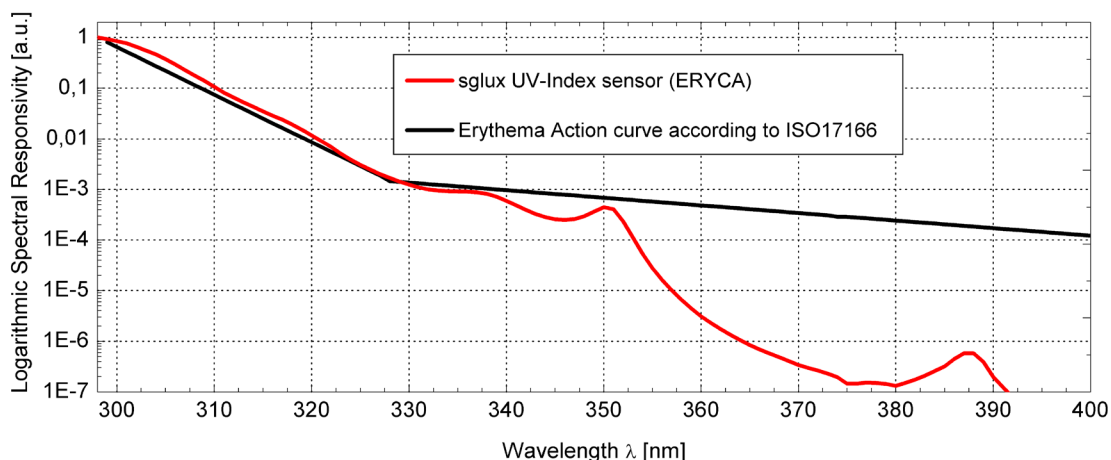

Figure 1: spectral responsivity of the UVI-Solo compared with the Erythema action curve as defined by ISO 17166

UV Sensor "UVI-Solo"

Pole or railings mounted UV sensor for UV-Index measurements



GENERAL SPECIFICATIONS

<i>Fixed Specifications</i>	Parameter	Value
	Dimensions	Please refer to drawing on page 3.
	Field of view	Please refer to graph on page 3.
	Weight	375 g
	Temperature coefficient (30 to 65°C)	0.05 to 0.075%/K
	Operating temperature	-20 to +80°C
	Storage temperature	-40 to +80°C
	Humidity	< 80%, non condensing
	Time constant	0.1s +/-20% - other time constants on request, device has 1st order low pass characteristics
	Spectral Responsivity	UV-Index as defined by ISO 17166
	Measurement range	UVI 0 ... 30
	Ingress protection code	IP67

SIGNAL OUTPUT SPECIFICATIONS

Signal Output 0 to 10V	proportional to the UVI
Supply voltage	12 to 24 VDC
Current consumption	< 30mA
Connections	2m cable version: V-=brown, V+=white, V _{OUT} =green, shield=black plug version: not available
Dark offset voltage	< 0.3 mV

UV Sensor "UVI-Solo"

Pole or railings mounted UV sensor for UV-Index measurements

FIELD OF VIEW

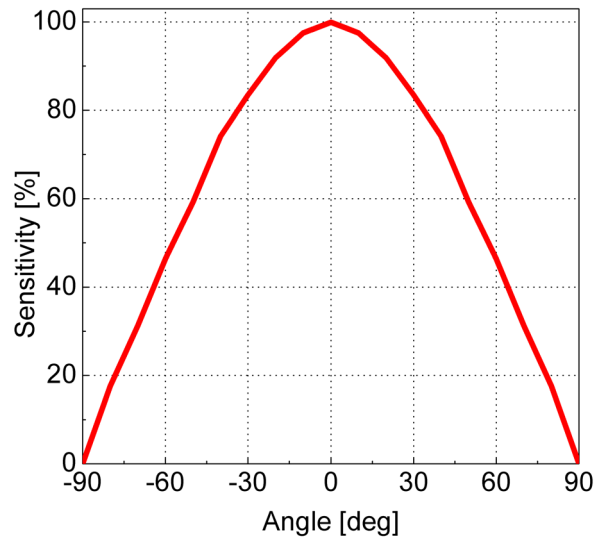

DRAWING (values in mm)

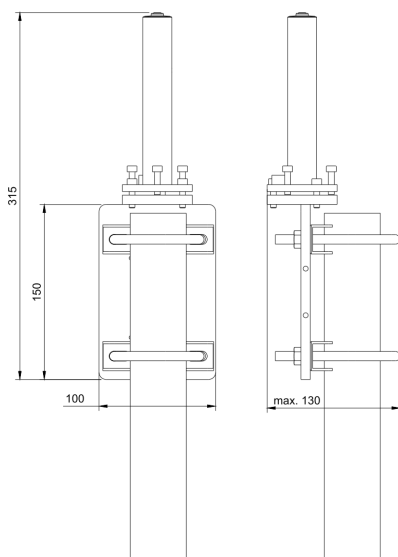

Drawing of mast mounted sensor

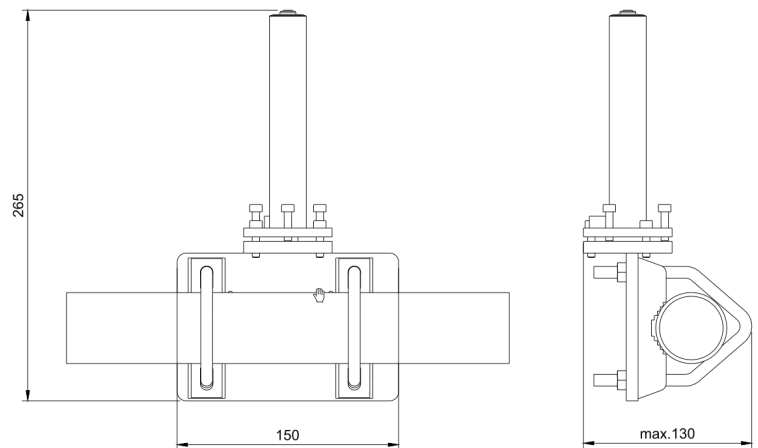

Drawing of rail mounted sensor