

# SENSOR MONITOR 5.0

Radiation monitor and controller



## GENERAL FEATURES



### Properties of the Sensor Monitor 5.0 series

The Sensor Monitor 5.0 series are measurement and control modules for monitoring and automation of irradiation processes. They display radiation, dose and status information which is simultaneously provided via USB / RS232.

Three programmable relays allow an automated control of single- and multi-level irradiation processes.

The Sensor Monitor 5.0 is used as a radiation monitor or control module in disinfection, drying, hardening, biotechnology and in scientific research.

It is available with a NIST or PTB traceable calibration.

## SPECIFICATIONS

<i>Fixed Specifications</i>	<b>Parameter</b>	<b>Value</b>
	Panel dimensions (L x W x H) (DIN 43700 - Uninorm)	144 mm x 86 mm x 72 mm
	Weight	140 g
	Cut-out at control cabinet (L x W)	137 mm x 67 mm
	Degree of protection	IP40
	Operating temperature	0 ... +70°C
	Storage temperature	-25 ... +85°C
	Power supply	12 ... 24 V <sub>DC</sub>
	Power consumption at 24 V <sub>DC</sub>	0.4 W

<i>Configurable Specifications</i>	<b>Parameter</b>	<b>Value</b>
	Number of probe inputs	1 or 2
	Data output	none or USB / RS232
	Number of relay outputs	3

## MODEL OVERVIEW

Sensor Monitor 5.0 Classic	One channel, no data output
Sensor Monitor 5.0 Connect	One channel, USB / RS232 data output
Sensor Monitor 5.0 Double	Two channels, no data output
Sensor Monitor 5.0 Double Connect	Two channels, USB / RS232 data output

# SENSOR MONITOR 5.0

Radiation monitor and controller



## CONNECTIONS AND OUTPUTS

### Sensor input



The input terminal can be connected to amplified probes with voltage output or photodiodes.

### Visualization of values and state



Each row of the user configurable illuminated display shows the following information:

- Radiation or dose (in selectable units) and relay state
- Error messages like overrange

### Data output

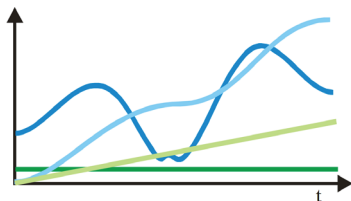

If the option *Connect* is selected the measurement data can be read out via USB or RS232 to a PC or PLC. The transfer is done with a CSV file which can be analyzed with a typical software like Origin or Excel.

### Relay functions

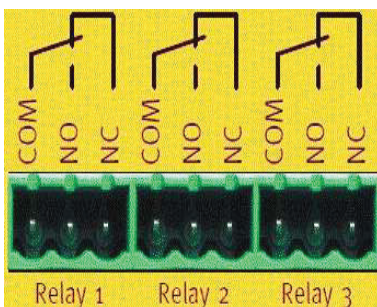

Three potential-free relays can be used for process control.

- Activation when exceeding or failing below a threshold intensity or reaching an irradiation dose (lamp switch and/or alarm).
- Logic combination, control of transport processes, switch conditions depending on dose, intensity and relative lamp output.

# SENSOR MONITOR 5.0

Radiation monitor and controller

## BASIC FUNCTIONS

### Radiation measurement

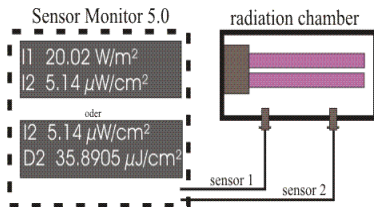

Parallel measurements of two lamp outputs or radiation parts of one lamp can be realized (e.g. UVA and UVB). In the first display example the intensity I<sub>1</sub> at sensor 1 and the intensity I<sub>2</sub> at sensor 2 is displayed. The second picture shows intensity and dose (time integration of the intensity). If the data port is activated the complete relevant information (intensities, doses, error messages and state of relays and dose measurements) is transferred to a PC.

### Measurement and lamp control

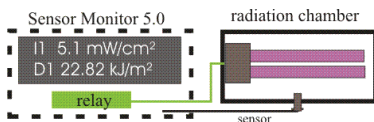

At exceeding or failing below a configurable intensity threshold or reaching an irradiation dose the lamp can be switched off or changed over to another lamp.

### Measurement and alarm

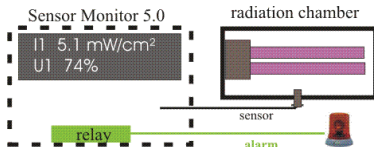

In the example an alarm is given if the percentaged lamp power falls below a configurable threshold. Further two relays can be used for other functions (switching of pumps, shutters, etc.).

### Transport control of irradiated goods

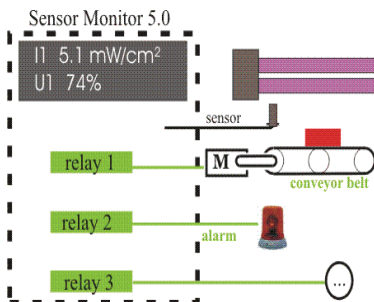

Measurement of the dose at irradiated goods and activation of the belt transport. The hold times of the relays are variable therefore the transport distance can be adjusted with the hold time. In the example a second relay is giving an alarm if the intensity falls below the threshold. The third relay can be used for information from a second sensor or for a logic combination with one of the other relays (e.g. transport if dose threshold is exceeded and intensity is higher than a minimum value at the same time).

# SENSOR MONITOR 5.0

Radiation monitor and controller



## ▶ ADVANCED USE IN PROCESS AUTOMATION

### Automated dose measurement

The measurement of irradiation doses can be done manually or subjected to automation conditions.

In the first example the dose measurement is started at exceeding a critical intensity. If the intensity falls below the threshold the integration is interrupted and the dose stays constant. While exceeding the threshold again, the integration is continued.

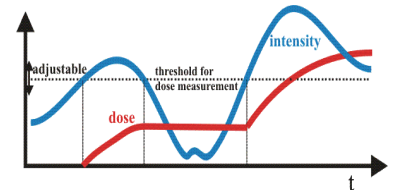

In the second example the dose measurement is finished with falling under the intensity threshold. The reset delay keeps the value on the display. At exceeding of the threshold a new dose is generated. The generation of single doses is used if the dose stop condition is activating a pump or a transport of a good (see below). For each irradiated good or segment a dose is calculated.

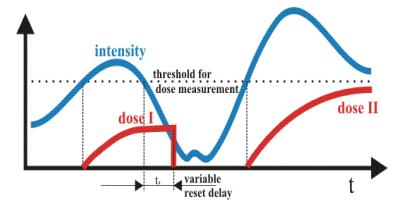

### Relay configuration

Three relays can be configured for controlling different functions activated by various configurable process conditions. In the simplest use the relays activate at falling under or exceeding a critical threshold of a selectable measure.

A warmup delay can be implemented to avoid false reports at the start-up process. Additionally it may be reasonable to ignore a short malfunction and only to consider a longer malfunction by using a relay activation delay. Hysteresis parameters can be set for values that are alternating around the threshold.

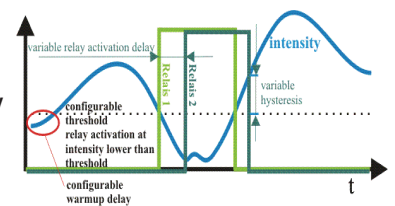

### Dose measurement indication

Each relay can be associated with dose functions. Running dose measurements can be indicated by an activated relay. There is no difference if the dose measurement is operated manually or under automated conditions.

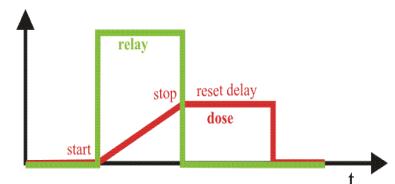

### Dose limit indication

At the dose limit indication the relay is activated if the dose measurement is finished. With the hold time the time of the relay activation is set.

