



Thermopiles for
temperature measurement
and gas detection



HEIMANN
Sensor

91 Boylston Street, Brookline, MA 02445
www.boselec.com | shop.boselec.com | boselec@boselec.com
617-566-3821

Thermopile Infrared Sensors

Heimann Sensor offers a wide range of thermopile sensors for non-contact temperature measurements and gas detection. Thermopiles consist of many thermocouples that are usually connected in series. They generate a small electric voltage when exposed to infrared (IR) radiation or heat. We produce sensor chips in different sizes. Small sensor chips like 0.6x0.6 mm² and 0.76x0.76 mm² are best for remote temperature measurements due to their optimized performance-cost ratio. The bigger chips like 1.2x1.2 mm² or even 2.1x2.1 mm² are ideally suited for gas detection. They provide enough signal to measure even high gas concentrations.

Besides single element sensors in various packages from SMD to small TO-46 and TO-39, we also produce sensors with two or four elements for gas concentration measurements.

All TO-packaged sensors can be equipped with a lens to reduce the field of view (FOV) to measure from larger distances or to provide a smaller measurement spot for more accurate temperature detection.

If you are looking for thermopile sensors with integrated signal conditioning, you might want to check out our thermopile modules.

Thermopile Infrared Sensor Modules

Heimann Sensor's thermopile modules consist of a thermopile sensor or thermopile array with an integrated ASIC for signal conditioning. The ASIC amplifies the small sensor's voltage and provides either an analog or a digital output. In the case of an analog output, you receive the amplified sensor voltage value. In the case of a digital output, it is possible to select between voltage and temperature value.

All modules have an integrated linear temperature reference voltage. This voltage (in the analog case) or voltage value (in the digital case) can be obtained from a separate output channel.



Heimann Thermopiles - how to select

Need to decide on **ACTIVE AREA, NUMBER OF ELEMENTS, PACKAGE, AND FILTER/WINDOW.**
 OPTIONALLY add **AMPLIFICATION** (inside package or outside) and **OPTICS** (lens, mirror)

Active Area		4 standard active areas are available.			
CODE >>	1	2	3	1C	
AREA mm ² (rectangular)	0.61x0.61	1.2x1.2	2.1x2.1	0.85x0.85	
Chips	small, low cost	large, high signal	largest, higher signal, higher cost	midsize	
	used for temp sensing usually	used for gas sensing usually	used for gas sensing usually	temp or gas	
Active area = area of highest absorption. Heimann's main advantage over competitors is small thermal time constant. The heat capacity of Heimann elements is small, which makes them fast.					
Number of elements	single, dual and quad are standard. 3x3, 1x8 and 1x16 available as engineering samples				
Thermistors	CODE: second digit	n 1 = 100 kOhm thermistor; n 2 = 30 kOhm thermistor			

Spectral Response		A variety of filters are stocked	
Filters are chosen depending on the application			
Application	Filter		
Temp measurement, short distance to target	5.5 micron LWP		
Temp measurement, when distance to target makes atmospheric absorption significant	8 to 14 micron BP		
Gas sensing	Gas	filter ctr_wl/HPBW (standard)	Also Available
	CO2	4.26/0.18 or 0.09	4.43/0.06 (band edge)
	CO	4.64/0.18	and per customer specification
	HC	3.4/0.19	
	Reference	3.91/0.09	
	others	customer specified	
uncoated windows	uncoated Si, CaF, sapphire - yet might not always be in stock for all window sizes		

Sensor Packages				
	Code	Type	Comment	
Packages	HCM	C	Surface mount with ASIC	
	HID	E	TO-39 with ASIC and Digital Output Voltage	
	HIM	J	TO-46 with ASIC	
	HIS	various	TO-39 with ASIC	
	HTS	A	TO-5 (TO-39)	2.5 mm dia aperture
	HTS	B		3.8 mm dia aperture
	HTS	C		3.5x3.5 mm aperture; not encouraged
	HTS	D		customized product
	HTS	I		internal FOV aperture
	HTS	E		Dual aperture
	HTS	Q		Quad aperture
	HMS	M		TO-18 (TO-46)
	HMS	J / K	TO-18 (TO-46) Mini	J with tab, K no tab, "1" or "1C" or 2 chip only
	HMS	Z	Baby	no tab, "1" chip only

Sensor Modules with electronics		customers can get the timing and protocol requirements for re-programming	
	Code		
Electronics	HTIA (typical application is temp measurement)	PCB type with chip-on-board , TO39 cap	Analog single channel ASIC with EEPROM adjusted to customer requirements
		B	external mirror optics
		C	cap aperture 2.5mm dia , filter type typ. F5.5
		D	internal mirror optics , typ. F5.5
		E	lens optics focal length 4.4mm, typ. F5.5
Electronics	HIS 6PIN (typical application is temp of gas measurement)	TO39 housing	Single channel ASIC with EEPROM adjusted to customer requirements
		C	cap aperture 2.5mm dia , filter type typ. F5.5
		E	lens optics focal length 3mm or 4.4mm
Electronics	HIS 4PIN (typical application is gas measurement)	TO39 housing	Single channel ASIC with EEPROM max. amplification pref. for gas detection
		A	cap aperture 2.5mm dia , filter type typically gas , typically chip type 2



91 Boylston St, Brookline MA 02445 USA
 (800)347-5445 or (617)566-3821
 boselec@boselec.com www.boselec.com

Target Gas (comment)	Center Wavelength (nm)	Half Power Bandwidth (nm)
<i>CH₄</i>	3300	160
<i>HC</i>	3375	190
<i>CO₂ (0 to 5000 ppm)</i>	4260	180
<i>CO₂ (1000 ppm to 10%)</i>	4300	110
<i>CO₂ (1% to 100%)</i>	4430	60
<i>CO</i>	4640	180
<i>NO</i>	5300	180
<i>Reference (clear)</i>	3910	90

Thermopile Infrared Sensors

Heimann Sensor offers a wide range of thermopile sensors for non-contact temperature measurements and gas detection. Thermopiles consist of many thermocouples that are usually connected in series. They generate a small electric voltage when exposed to infrared (IR) radiation or heat. We produce sensor chips in different sizes. Small sensor chips like 0.6x0.6 mm² and 0.76x0.76 mm² are best for remote temperature measurements due to their optimized performance-cost ratio. The bigger chips like 1.2x1.2 mm² or even 2.1x2.1 mm² are ideally suited for gas detection. They provide enough signal to measure even high gas concentrations.

Besides single element sensors in various packages from SMD to small TO-46 and TO-39, we also produce sensors with two or four elements for gas concentration measurements.

All TO-packaged sensors can be equipped with a lens to reduce the field of view (FOV) to measure from larger distances or to provide a smaller measurement spot for more accurate temperature detection.

If you are looking for thermopile sensors with integrated signal conditioning, you might want to check out our thermopile modules.





HCS C-Series

Single SMD Thermopile Sensor

The HCS C-Series provides a single thermopile sensor with application specific optical filter. It comes in a leadless ceramic package with a small footprint of $3.8 \times 3.8 \text{ mm}^2$ and a low thickness of 1.45mm. The device includes a selectable thermopile chip and an optional thermistor providing a temperature reference.

The sensor can be equipped with a large variety of optical filters depending on the targeted application. A broad band filter ensures a high signal for temperature measurements. A narrow band filter can be used for gas concentration measurements.

The module has a large operating range from -40°C to 120°C .

Dimensions

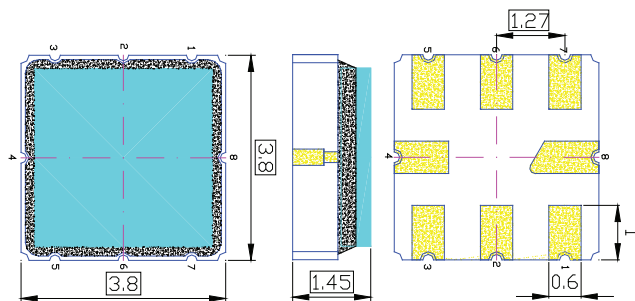

Filter Types for Temperature Measurements

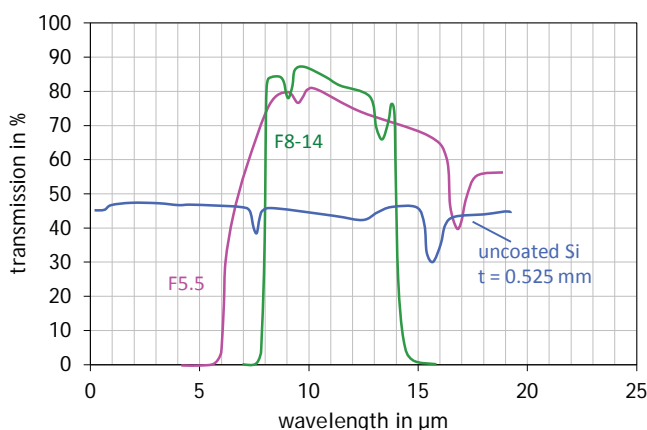

Filter Types for Gas Analysis (General List)

Gas	CWL / nm	HPBW / nm	Filter
CH ₄	3300	160	F3.30/160
HC	3375	190	F3.375/190
CO ₂	4260	180	F4.26/180
CO ₂	4300	110	F4.30/110
CO ₂	4430	60	F4.43/60
CO	4640	180	F4.64/180
CO	4640	90	F4.64/90
N ₂ O	4530	85	F4.53/85
NO	5300	180	F5.30/180
(Reference)	3910	90	F3.91/90

PIN-Configuration

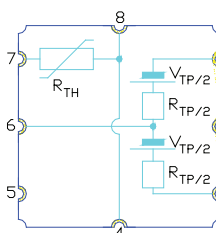

Pin No.	Symbol	Description
1	TP-	Thermopile minus
3	TP+	Thermopile plus
4/8	TH	Thermistor 1 (ground layer)
6	TPO	Thermopile central tapping
7	TH	Thermistor 2

Characteristics

	HCS C11	HCS C1c1	HCS C21	Unit
Element size	0.61 ²	0.76 ²	1.2 ²	mm ²
Voltage response ^{a)}	22	30	63	Vmm ² /W
Sensitivity ^{a)}	58	52	44	V/W
T/C of sensitivity ^{b)}	00.2	00.2	00.2	%/K
Resistance R _{TP} ^{b)}	86	75	84	kOhm
TC of resistance R _{TP} ^{b)}	0.02	0.02	0.02	%/K
Noise ^{b)}	38	35	37	nV / Hz ^{1/2}
Detectivity ^{a),b)}	0.9·10 ⁸	1.1·10 ⁸	1.4·10 ⁸	cm Hz ^{1/2} / W
Time constant	5	8	10	ms
Thermistor reference ^{b)}	100	100	100	kOhm
Temp. coeff. of thermistor ^{d)}	3940	3940	3940	K
Field of view	120			°
Operating temperature	-20 ... 120			°C
Storage temperature	-40 ... 120			°C

a) Without filter, T_{obj} = 100°C, DC
 b) At T_{amb} = 25°C
 c) 25°C, 50°C

Ordering Information

HCS	Heimann Ceramic Sensor
C	SMD package
1, 1c, 2	Thermopile chip
1, 0	1 = with thermistor, 0 = no thermistor
Fx	Application specific filter

E.g.: HCS C1c1 F5.5



HMS M-Series

Thermopile Sensors for Remote Temperature Measurements

The HMS M-Series provides an integrated lens in a small TO-46 transistor housing which is ideally suited for narrow fields of view with small measurement spots. This allows accurate temperature measurements at greater distances.

The HMS M-Series thermopile sensors feature high sensitivity, a small temperature coefficient of sensitivity and high reproducibility and reliability.

The smallest thermopile chip TP1 is well suited for temperature measurements which require a precise measuring spot, whereas the thermopile chip type TP2 is optimized for higher voltage signals.

Dimensions and PIN-Configuration

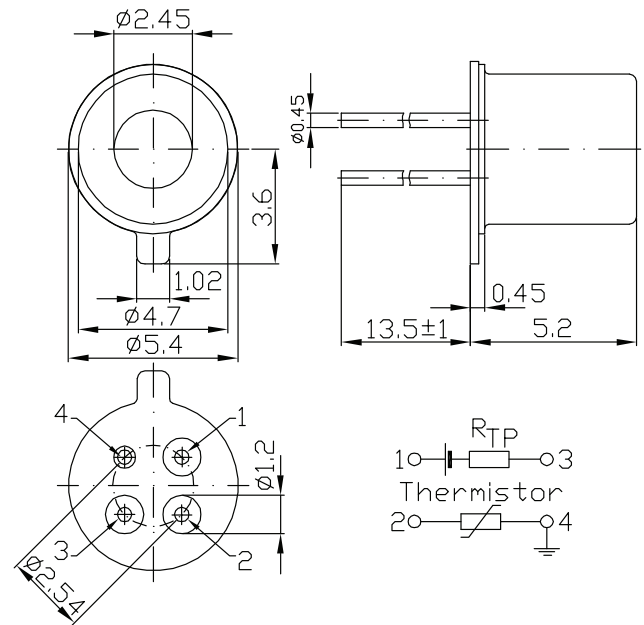

Filter Options

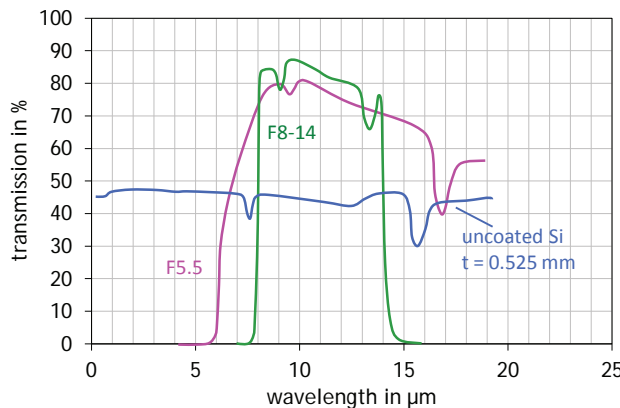

Field-of-View

Sensor	M11 L3.0	M1c1 L3.0	M21 L3.0	M21 L2.1
Field of View	12°	14°	16°	28°

Characteristics

	HTS M11	HTS M1c1	HTS M21	Unit
Element size	0.61 ²	0.76 ²	1.2 ²	mm ²
Voltage response ^{a)}	22	30	63	Vmm ² /W
Sensitivity ^{a)}	58	52	44	V/W
Resistance R _{TP} ^{b)}	86	75	84	kOhm
TC of resistance R _{TP} ^{b)}	0.02	0.02	0.02	%/K
Noise ^{b)}	38	35	37	nV/Hz ^{1/2}
Detectivity ^{a),b)}	0.9·10 ⁸	1.1·10 ⁸	1.4·10 ⁸	cm·Hz ^{1/2} /W
Time constant	<5	8	10	ms
Thermistor reference ^{b)}	100	100	100	kOhm
Temp. coeff. of thermistor ^{c)}	3940	3940	3940	K
Operating temperature	-20 ... 120			°C
Storage temperature	-40 ... 120			°C

a) Without filter, T_{obj} = 100°C, DC
 b) At T_{amb} = 25°C
 c) 25°C, 50°C

Ordering Information

HMS	Heimann Miniature Sensor
M	Package type (TO-46 with lens)
1, 1C, 2	Thermopile chip
1, 0	Thermistor 100kΩ, no thermistor
Lx	Lens type (focal length)
Fx	Filter type

E.g.: HMS M21 L3.0 F5.5



HMS P-Series

Heat Shock Compensating Miniature Thermopile Sensors for Temperature Measurements

The HMS P-Series offers CMOS compatible thermopile sensor chips in a TO-46 housing with lower heat shock response to external temperature changes by factor 5 compared to our standard HMS J- and K-Series sensors.

This allows highly accurate, reproducible and reliable measurements even under instable ambient conditions.

They feature a 50% higher sensitivity and a small temperature coefficient of sensitivity resulting in an improved temperature measurement performance.

Different available filters offer additional design flexibility and allow to customize the sensor according to your requirements.

Dimensions

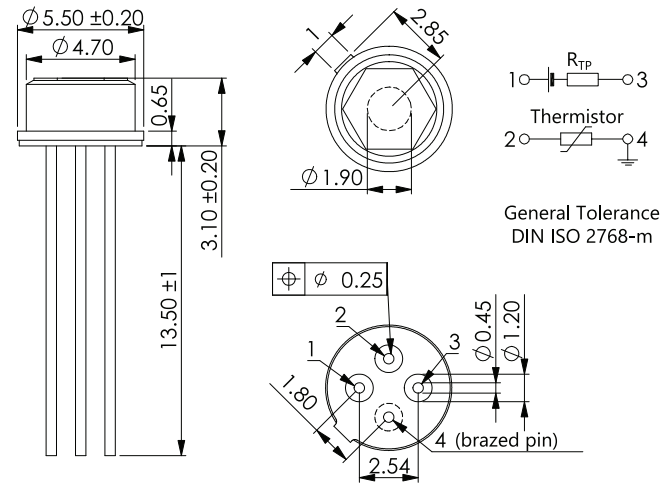

Heat Shock Response

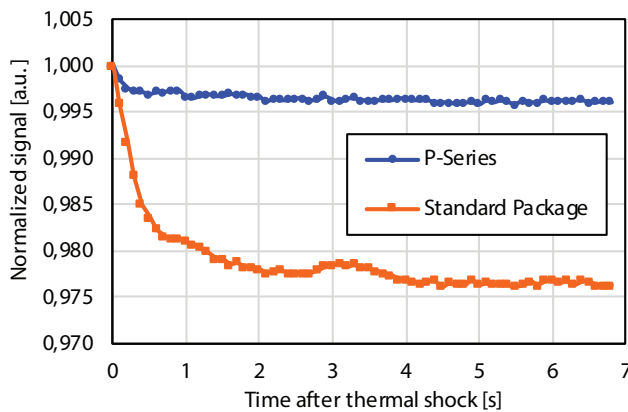

Characteristics

	HMS P11	HMS P1c1	HMS P21	Unit
Element size	0.61 ²	0.76 ²	1.2 ²	mm ²
Voltage response ^{a)}	22	30	63	Vmm ² /W
Sensitivity ^{a)}	77	68	55	V/W
Resistance R _{TP} ^{b)}	86	75	84	kOhm
TC of resistance R _{TP} ^{b)}	0.02	0.02	0.02	% / K
Noise ^{b)}	38	35	37	nV / Hz ^{1/2}
Detectivity ^{a),b)}	0.84·10 ⁸	1.0·10 ⁸	1.4·10 ⁸	cm Hz ^{1/2} / W
Time constant	<5	10	10	ms
Thermistor reference ^{b)}	100	100	100	kOhm
Field of view ^{d)}	87	87	87	°
Temp. coeff. of thermistor ^{c)}	3940	3940	3940	K
Operating temperature	-20 ... 120			°C
Storage temperature	-40 ... 120			°C

a) Without filter, T_{obj} = 100°C, DC
b) At T_{amb} = 25°C

c) 25°C, 50°C
d) Deg at 50% signal level

Filter Types for Temperature Measurements

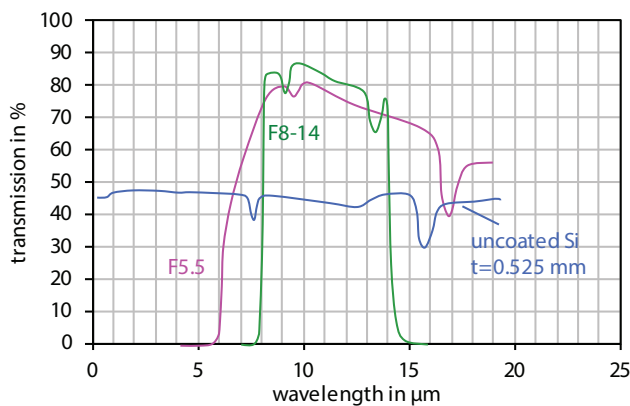

Ordering Information

HMS	Heimann miniature thermopile sensor
P	Low Heat Shock – TO-46
1, 1c, 2	Thermopile Chip Size
1, 0	Thermistor 100kΩ, no thermistor
Fx	Filter type

Field of View

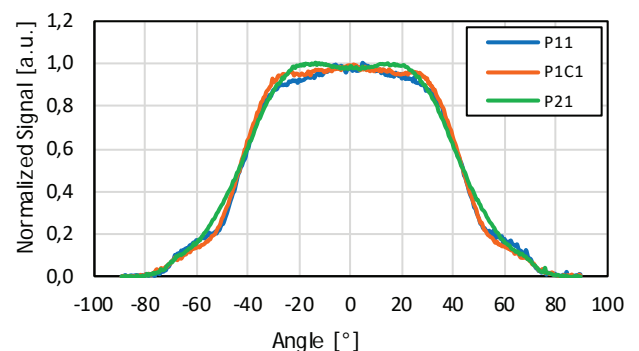



HMS Series

Miniature Thermopile Sensors for Remote Temperature Measurement and Gas Analysis

The HMS Series offers CMOS compatible thermopile sensor chips in TO-46 and even smaller transistor housings.

They feature high sensitivity, small temperature coefficient of sensitivity and high reproducibility and reliability.

The small package sizes allow applications in which sensor mounting is a critical parameter. Especially the HMS Z11 sensor opens new design and application possibilities.

The small TP1 thermopile chip is best for temperature measurements with a precise measuring spot, whereas the TP2 thermopile chip provides higher voltage signal.

Filter types for Temperature Measurements

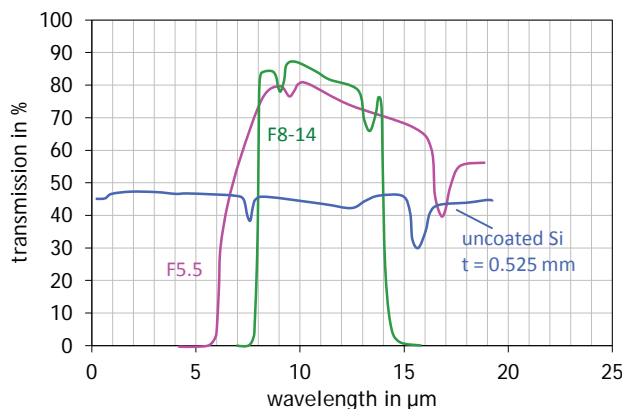

Filter types for Gas Analysis

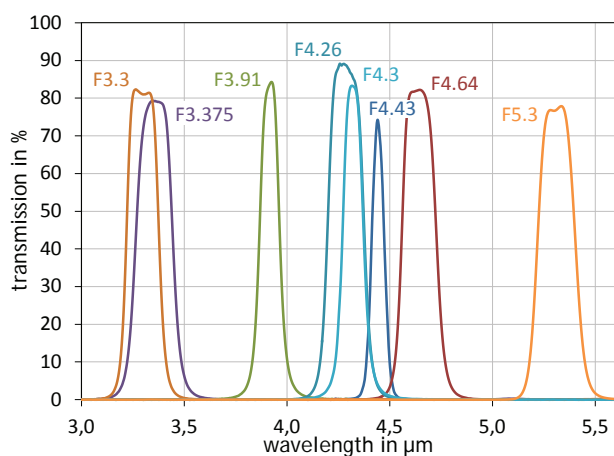

Ordering Information

HMS	Heimann miniature thermopile sensor
J, K, Z	Package type (TO-46, μ-TO)
1, 1c, 2	Thermopile chip
1, 0	Thermistor 100kΩ, no thermistor
Fx	Filter type

Dimensions

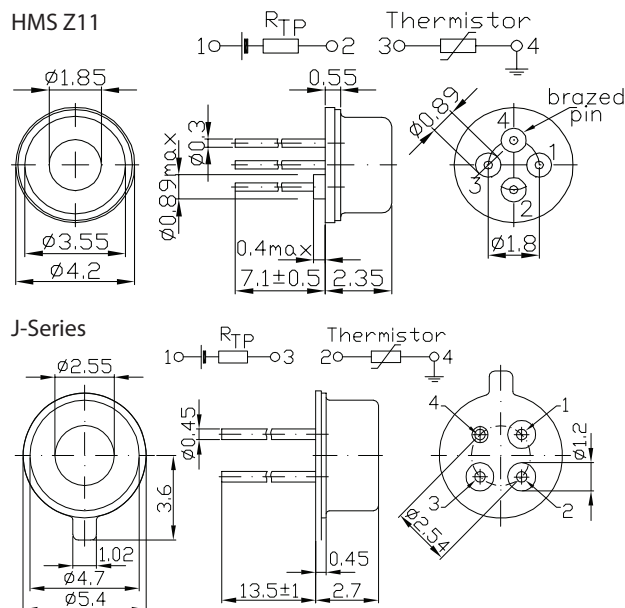

Characteristics

	HMS Z11	HMS J11	HMS J1c1 K1c1*	HMS J21	Unit
Element size	0.61 ²	0.61 ²	0.76 ²	1.2 ²	mm ²
Voltage response ^{a)}	22	22	30	63	Vmm ² /W
Sensitivity ^{a)}	58	58	52	44	V/W
Resistance R _{TP} ^{b)}	86	86	75	84	kOhm
TC of resistance R _{TP} ^{b)}	0.02	0.02	0.02	0.02	%/K
Noise ^{b)}	38	38	35	37	nV/Hz ^{1/2}
Detectivity ^{a),b)}	0.9·10 ⁸	0.9·10 ⁸	1.1·10 ⁸	1.4·10 ⁸	cm Hz ^{1/2} /W
Time constant	<5	<5	8	10	ms
Thermistor reference ^{b)}	100	100	100	100	kOhm
Temp. coeff. of thermistor ^{d)}	3940	3940	3940	3940	K
Field of view ^{d)}	95	120	120	120	°
Operating temperature	-20 ... 120				°C
Storage temperature	-40 ... 120				°C

a) Without filter, T_{obj} = 100°C, DC
 b) At T_{amb} = 25°C
 c) 25°C, 50°C
 d) deg at 50% signal level
 *same as J1c1, without orientation nose

Filter-Selection-Guide

Gas	- (ref)	CO ₂	HC	CO	NO
Filter (CWL/HPBW in μm/nm)	F3.91/90	F4.26/180	F3.3/160	F4.64/180	F5.3/180
		F4.30/110	F3.375/190		
			F4.43/60		

E.g.: HMS Z11 F5.5
 HMS J21 F4.26/180



HTS Series

Thermopile Sensors for Remote Temperature Measurement and Gas Analysis

The HTS Series consists of a thermopile sensor chip in a TO-39 transistor housing and features high sensitivity, reproducibility and reliability as well as a small temperature coefficient of sensitivity.

The smallest thermopile chip TP1 is well suited for temperature measurements which require a precise measuring spot whereas the thermopile chip type TP3 is optimized for highest signal outputs.

Additionally, Heimann Sensor can offer integrated thermopile sensors (HIS series) combining a thermopile sensor chip with an ASIC in a TO-39 housing.

Dimensions and PIN-Configuration

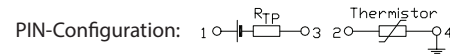
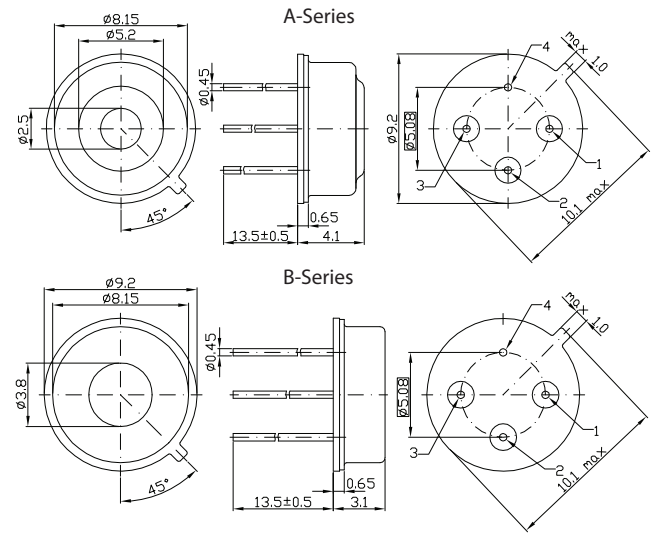

Filter Types for Temperature Measurements

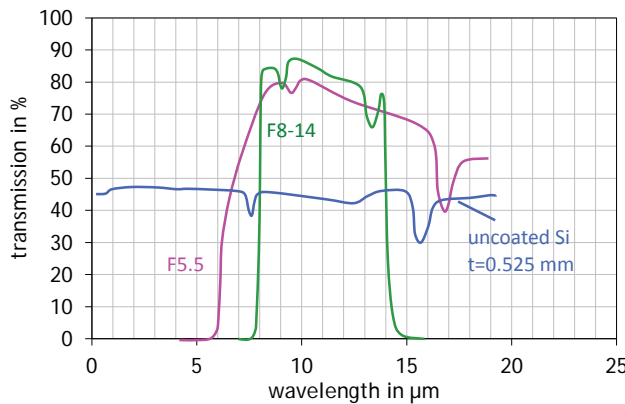

Filter Types for Gas Analysis

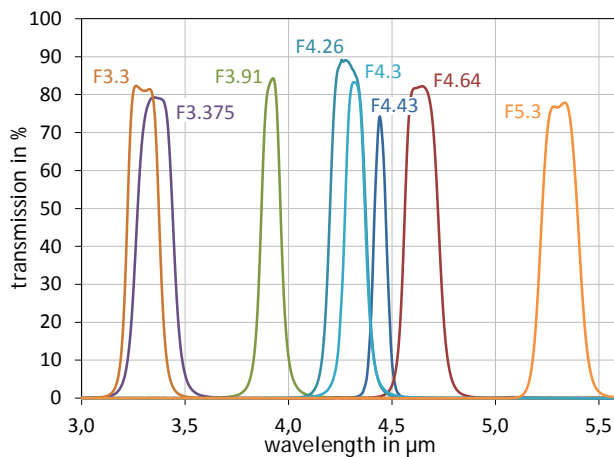

Characteristics

	HTS A11	HTS A1c1	HTS A21 B21	HTS A31 B31	Unit
Element size	0.61 ²	0.76 ²	1.2 ²	2.1 ²	mm ²
Voltage response ^{a)}	22	30	63	115	Vmm ² /W
Sensitivity ^{a)}	58	52	44	26	V/W
Resistance R_{Tp} ^{b)}	86	75	84	88	kOhm
TC of resistance R_{Tp} ^{b)}	0.02	0.02	0.02	0.02	%/K
Noise ^{b)}	38	35	37	38	nV/Hz ^{1/2}
Detectivity ^{a),b)}	0.9·10 ⁸	1.1·10 ⁸	1.4·10 ⁸	1.5·10 ⁸	cm Hz ^{2/3} /W
Time constant	< 5	8	10	18	ms
Thermistor reference ^{b)}	100	100	100	100	kOhm
Temp. coeff. of thermistor ^{c)}	3940	3940	3940	3940	K
Field of view (A) ^{d)}	70	70	70	70	°
Field of view (B) ^{d)}			100	100	°
Operating temperature		-20 ... 120			°C
Storage temperature		-40 ... 120			°C

- a) Without filter, $T_{obj} = 100^{\circ}\text{C}$, DC
- b) At $T_{amb} = 25^{\circ}\text{C}$
- c) 25°C , 50°C
- d) Degree at 50% signal level

Filter Selection Guide

Gas	- (ref)	CO ₂	HC	CO	NO
Filter (CWL/HPBW in $\mu\text{m}/\text{nm}$)	F3.91/90	F4.26/180	F3.3/160	F4.64/180	F5.3/180
		F4.30/110	F3.375/190		
		F4.43/60			



HTS L-Series

Thermopile Sensors for Remote Temperature Measurements

The HTS L-Series provides an integrated lens in a TO-39 transistor housing which is ideally suited for narrow fields of view with small measurement spots. This allows accurate temperature measurements at greater distances.

The HTS L-Series thermopile sensors feature high sensitivity, a small temperature coefficient of sensitivity and high reproducibility and reliability.

Additionally, Heimann Sensor offers integrated thermopile sensors (HIS series), which combine a thermopile sensor chip with an ASIC in a TO-39 housing.

Dimensions and PIN-Configuration

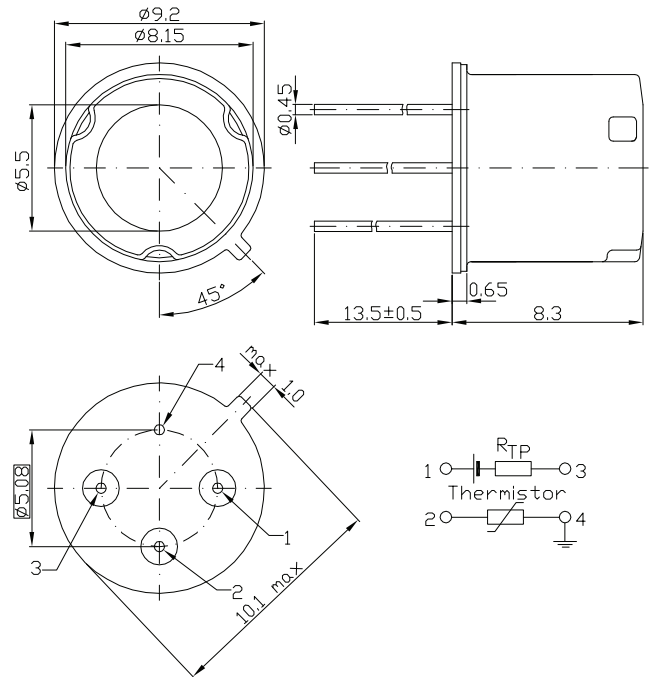

Filter Options

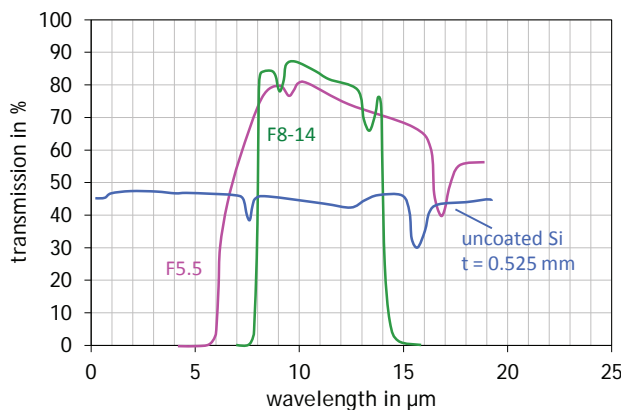

Characteristics

	HTS L11	HTS L1c1	Unit
Element size	0.61 ²	0.76 ²	mm ²
Voltage response ^{a)}	19	27	V mm ² / W
Sensitivity ^{a)}	50	45	V / W
Resistance R _{TP} ^{b)}	86	75	kOhm
TC of resistance R _{TP} ^{b)}	0.02	0.02	% / K
Noise ^{b)}	38	35	nV / Hz ^{1/2}
Detectivity ^{a),b)}	8.0·10 ⁷	9.8·10 ⁷	cm Hz ^{1/2} / W
Time constant	<5	8	ms
Thermistor reference ^{b)}	100	100	kOhm
Temp. coeff. of thermistor ^{c)}	3940	3940	K
Field of view ^{d)}	5	6.5	°
Operating temperature	-20 ... 120		°C
Storage temperature	-40 ... 120		°C

a) Without filter, T_{obj} = 100°C, DC
 b) At T_{amb} = 25°C
 c) 25°C, 50°C
 d) Deg at 50% signal level

Ordering Information

HTS	Heimann Thermopile Sensor
L	Package type (TO-39 with lens)
1, 1C	Thermopile chip
1, 2, 0	Thermistor 100kΩ, 30kΩ, no thermistor
Lx	Lens type (focal length)
Fx	Filter type

E.g.: HTS L1C1 L3.0 F5.5



HTS-A-HT Series

Thermopile Sensors for High Ambient Temperature Operation

Similar to our HTS series of CMOS compatible thermopiles, the HTS-HT series features good sensitivity, small temperature coefficient of sensitivity and high reproducibility and reliability. The HT series is designed to work in a high temperature environment and can withstand operating temperatures up to 180°C. The standard version is offered with F8-14 bandpass window for remote temperature measurement. A version for CO₂ detection can be offered on demand.

Dimensions and PIN-Configuration

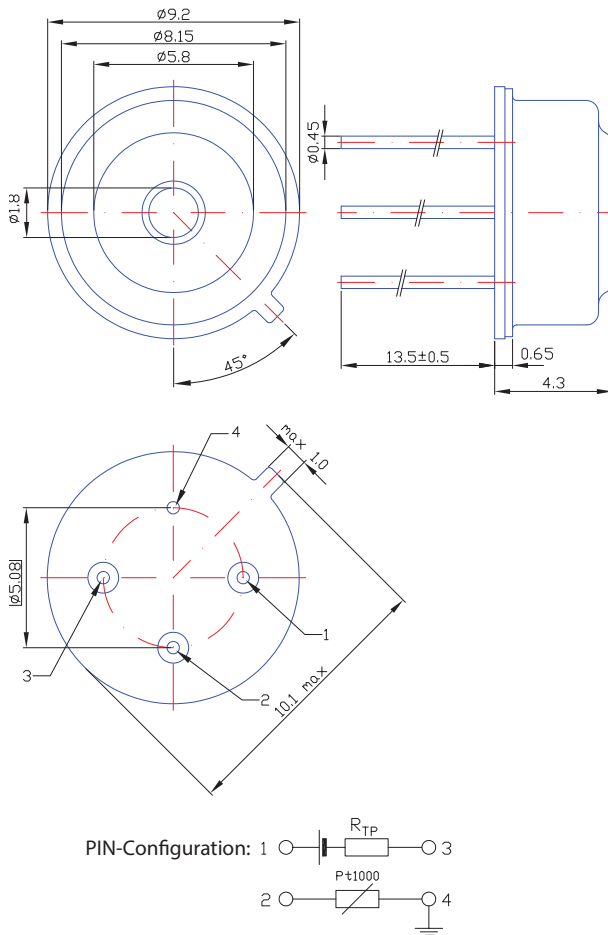

Typical Transmission with F8-14 Filter

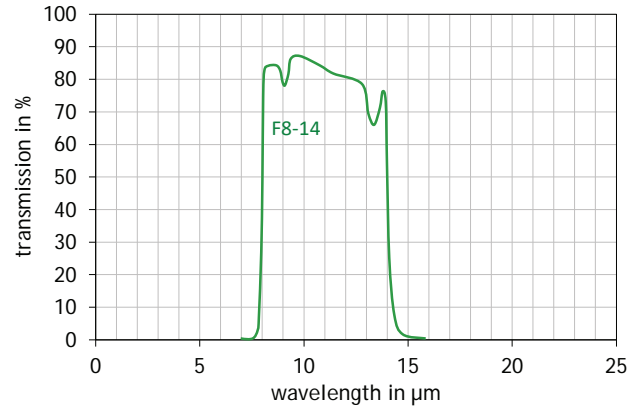

Characteristics

	HTS A10 F8-14 HT	HTS A14 F8-14 HT	HTS A20 F4.26 HT	Unit
Element size	0.61 ²	0.61 ²	1.2 ²	mm ²
Voltage response ^{a)}	22	22	63	V mm ² / W
Sensitivity ^{a)}	58	58	44	V / W
Resistance R_{TP} ^{b)}	86	86	84	kOhm
TC of resistance R_{TP} ^{b)}	0.02	0.02	0.02	% / K
Noise ^{b)}	38	38	37	nV / Hz ^{1/2}
Detectivity ^{a),b)}	0.9·10 ⁸	0.9·10 ⁸	1.4·10 ⁸	cm Hz ^{1/2} / W
Time constant	<5	<5	10	ms
Temperature reference ^{d)}	-	Pt 1000	-	Ohm
Field of view (A) ^{d)}	70	70	70	°
Operating temperature	-20 ... 180			°C
Storage temperature	-40 ... 180			°C

a) Without filter, $T_{obj} = 100^\circ\text{C}$, DC

b) At $T_{amb} = 25^\circ\text{C}$

c) At $T_{amb} = 0^\circ\text{C}$

d) Degree at 50% signal level

Ordering Information

HTS	Heimann Thermopile Sensor
A	Package type (TO-39)
HT	High Temperature
1, 2	Thermopile chip
0, 4	Temperature reference (none, Pt 1000)
Fx	Filter type

E.g.: HTS A10 F8-14 HT



HTS Multichannel Series

Multichannel Thermopile Sensors for Gas Analysis

The HTS Multichannel Sensors offer 2 or 4 independent sensor elements for multichannel gas concentration measurements in a small TO-39 metal housing.

Typically, one to three channels are equipped with gas specific filters for different center wavelengths (CWL). The other channel serves as a reference and is equipped with a filter with CWL where no absorption occurs.

In general, a broadband filter will result in higher signal outputs. A narrowband filter with low half power bandwidth (HPBW) will allow high measurement accuracy. For customized filters please contact our Heimann customer support.

Dimensions

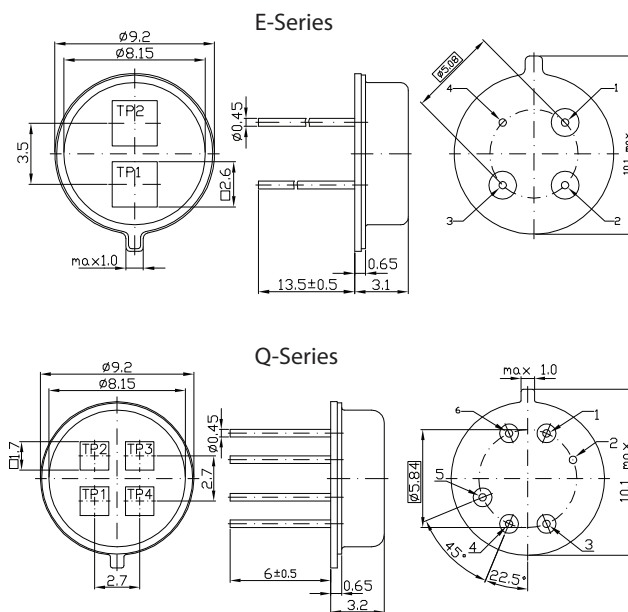

Filter Options

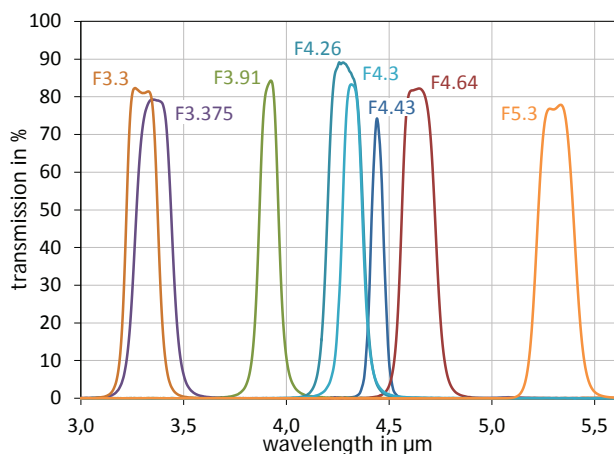

PIN-Configuration

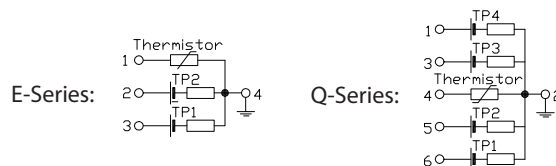

Characteristics

	HTS Q21	HTS E21	HTS E31	Unit
Number of channels	4	2	2	
Element size	1.2 ²	1.2 ²	2.1 ²	mm ²
Voltage response ^{a)}	63	63	115	Vmm ² / W
Sensitivity ^{a)}	44	44	26	V / W
Resistance R_{TP} ^{b)}	84	84	84	kOhm
TC of resistance R_{TP} ^{b)}	0.02	0.02	0.02	% / K
Noise ^{b)}	37	37	38	nV / Hz ^{1/2}
Detectivity ^{a),b)}	1.4 · 10 ⁸	1.4 · 10 ⁸	1.5 · 10 ⁸	cm Hz ^{1/2} / W
Time constant	10	10	18	ms
Thermistor reference ^{b)}	100	100	100	kOhm
Temp. coeff. of thermistor ^{c)}	3940	3940	3940	K
Operating temperature	-20 ... 120			°C
Storage temperature	-40 ... 120			°C

a) Without filter, $T_{obj} = 100^\circ\text{C}$, DC
 b) At $T_{amb} = 25^\circ\text{C}$

c) 25°C, 50°C

Filter-Selection-Guide

Gas	- (ref)	CO ₂	HC	CO	NO
Filter (CWL/HPBW in $\mu\text{m}/\text{nm}$)	F3.91/90	F4.26/180	F3.3/160	F4.64/180	F5.3/180
		F4.30/110	F3.375/190		
		F4.43/60			

Ordering Information

HTS	Heimann thermopile sensor
Q, E	Package type (TO-39) and number of channels (Q=4, E=2)
2, 3	Thermopile chip
1, 2, 0	Thermistor 100k Ω , 30k Ω , no thermistor
Fx / Fy	Filter types

E.g.: HTS E21 F3.91 / F4.26
 HTS Q21 F3.91 / F4.26 / F3.3 / F4.64

Thermopile Infrared Sensor Modules

Heimann Sensor's thermopile modules consist of a thermopile sensor or thermopile array with an integrated ASIC for signal conditioning. The ASIC amplifies the small sensor's voltage and provides either an analog or a digital output. In the case of an analog output, you receive the amplified sensor voltage value. In the case of a digital output, it is possible to select between voltage and temperature value.

All modules have an integrated linear temperature reference voltage. This voltage (in the analog case) or voltage value (in the digital case) can be obtained from a separate output channel.





HIS A-Series

Thermopile Integrated Sensor Modules for Gas Analysis and Temperature Measurement

The HIS Series devices include a thermopile sensor chip (optional TP1, TP1c, TP2, TP3) and an analog processing circuit in a TO-39 metal housing with 4 pins.

The sensor provides on analog outputs a high-accuracy amplification of the thermopile voltage with gain preset to 4300 or 2150 and an integrated temperature reference with a sensitivity of typically 15.5 mV/°C.

For gas detection, the sensors can be equipped with narrow band filters providing the gas specific center wavelength (CWL) and narrow half power bandwidth (HPBW).

For temperature measurements, we offer the standard filters F5.5 and F8-14 (atmospheric window).

Characteristics Sensor Chip

	TP1	TP1c	TP2	TP3	Unit
Element size	0.61 ²	0.76 ²	1.2 ²	2.1 ²	mm ²
Time constant sensor chip	5	8	10	18	ms
Sensitivity ^{a)}	58	52	44	26	V/W
Resistance R _{TP} ^{b)}	86	75	84	88	kOhm
Voltage response ^{a)}	22	30	63	115	Vmm ² /W

a) Without filter, T_{obj} = 100°C, DC
b) At T_{amb} = 25°C

Filter Options Gas Detection

Gas	REF	CO ₂	HC	CO	NO
Filter (CWL/HPBW)	F3.91/90	F4.26/180	F3.3/160	F4.64/180	F5.3/180
		F4.30/110	F3.37/190		
		F4.43/60			

Dimensions and PIN-Configuration

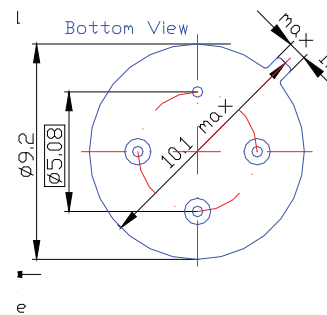
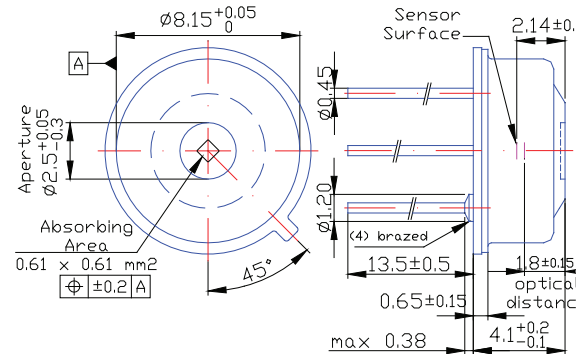

Pin No.	Symbol	Description
1	TPO	Analog thermopile output voltage
2	TRO	Analog temp. ref. output voltage
3	VDD	Supply (V+)
4	VSS	Supply (GND)

Characteristics Module

	HIS Ax1	HIS Ax2	Unit
Supply voltage	5	2.7 ... 5.5	V
Supply current	1	1	mA
Max. startup time after POR	0.5	0.5	s
PSRR	>40	>40	dB
Output voltage range	0.15.. (VDD-0.15)		V
Zero input sensor signal	1.225	1.2	V
Sensor gain preset	5600	4300 or 2150	V/V
Temp. ref. voltage ^{a)}	1.225	1.5	V
Sensitivity temp. ref.	15	16	mV/°C
Field of view ^{b)}	>70	>70	°
Operating temperature	-20 ... 120	-20 ... 120	°C
Storage temperature	-40 ... 125	-40 ... 125	°C

a) At T_{amb} = 25°C
b) Depending on the thermopile chip element size

Ordering Information

HIS	Heimann Integrated Sensor Module with analog outputs
Ax2	Standard cap, without optics
(x= 1, 1c, 2, 3)	Thermopile sensor chip
Fx	Filter (x= standard filter options or customized)
Gx	Gain preset (x= 2150 or 4300)

E.g.: HIS A22 F4.26/180 G4300



HIS E-Series

Thermopile Integrated Dual Sensor Modules for Gas Analysis

The HIS E222 is a two-channel thermopile sensor with integrated processing circuit providing high-accuracy amplification on analog voltage outputs. It comes in a 4 pin TO-39 housing. The sensor provides a wide operating range from 2.7 V to 5.5 V and -40°C to 120°C.

Heimann offers a large variety of filters for gas concentration measurements. Typically, one channel serves as reference where no gas absorption occurs. The other channel can be equipped with special filters providing the gas specific center wavelength (CWL) and very narrow half power bandwidth (HBPW).

The gain factor can be preset to 4300 or 2150 on both thermopile channels.

Characteristics

	HIS E222	Unit
Element size sensor chip	1.2 ²	mm ²
Time constant sensor chip	10	ms
Sensitivity ^{a)}	44	V / W
Voltage response ^{a)}	63	V mm ² / W
Resistance R _{TP}	84	kOhm
Supply voltage	3 ... 5	V
Supply current	2	mA
Max. start up time after POR	0.5	s
PSRR	>40	dB
Output voltage range	0.15.. (VDD-0.15)	V
Zero input sensor signal	1.2	V
Sensor gain preset	4300 or 2150	V/V
Field of view ^{b)}	>70	°
Operating temperature	-20 ... 120	°C
Storage temperature	-40 ... 125	°C

a) At T_{amb} = 25°C

b) At 50% voltage response

Dimensions and PIN-Configuration

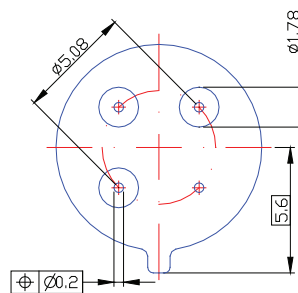
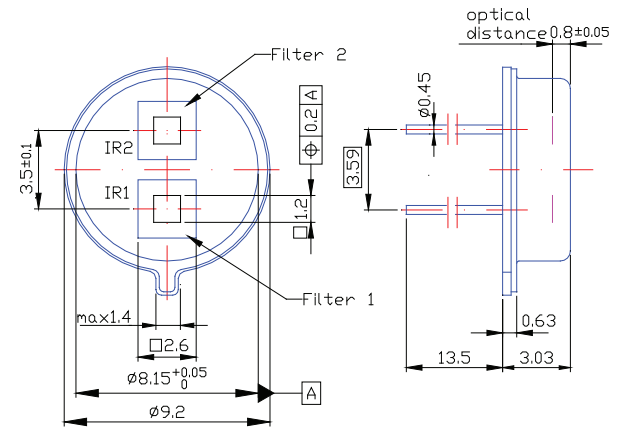

Pin No.	Symbol	Description
1	TPO1	Analog output voltage sensor 1
2	TPO2	Analog output voltage sensor 2
3	VDD	Supply (V+)
4	VSS	Supply (GND)

Filter Options

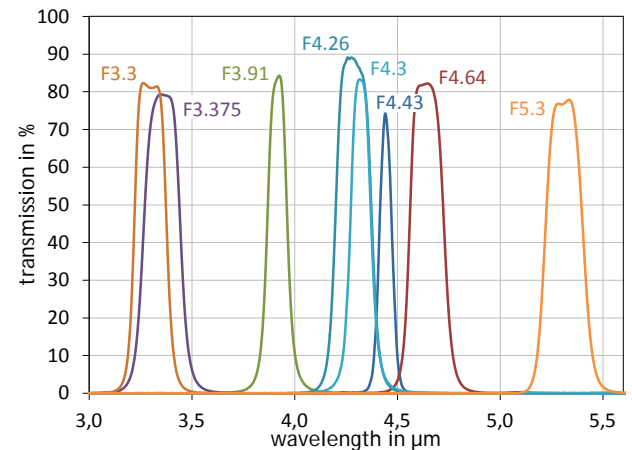

Gas	REF	CO ₂	HC	CO	NO
	F3.91/90	F4.26/180	F3.3/160	F4.64/180	F5.3/180
Filter (CWL/HBPW)		F4.30/110	F3.37/190		
		F4.43/60			

Ordering Information

HIS	Heimann Integrated Sensor Module
E222	Dual type with two sensor chips TP2 and analog IC
F1 F2	Filter options (F1->IR1 ; F2->IR2 ; standard or customized)
Gx	Gain preset (x= 2150 or 4300)

E.g.: **HIS E222 F3.91-90 F4.26-180 G4300**



HCM C-Series

Single SMD Thermopile Module

The HCM C-Series includes a surface mountable thermopile module optimized for gas analysis. It comes in a leadless ceramic package with a small footprint of 3.8x3.8mm² and a low thickness of 1.45mm. The module comes with a thermopile chip and an integrated ASIC for high-accuracy amplification selectable at 4300 or 2150. The conditioned thermopile sensor voltage and an on-chip linear temperature reference voltage are provided at analog output pins.

The sensor can be equipped with a large variety of filters depending on the targeted application.

The module has a wide operating range from 2.7 V to 5 V and -40°C to 120°C.

Dimensions and PIN-Configuration

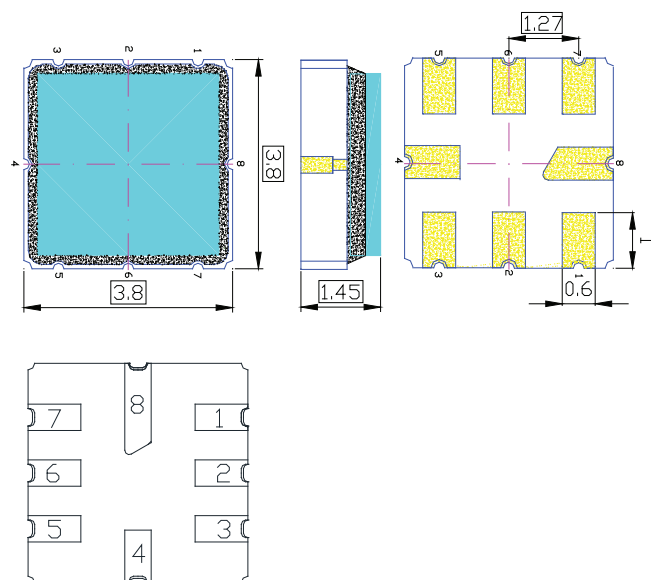

Characteristics

	HCM C12	HCM C1c2	HCM C22	Unit
Element size	0.61 ²	0.76 ²	1.2 ²	mm ²
Voltage response ^{a)}	22	30	63	Vmm ² / W
Sensitivity ^{a)}	58	52	44	V / W
Resistance R _{TP} ^{b)}	86	75	84	kOhm
T/C of sensitivity ^{b)}	0.02	0.02	0.02	% / K
Noise ^{b)}	38	35	37	nV / Hz ^{1/2}
Detectivity ^{a),b)}	0.9·10 ⁸	1.1·10 ⁸	1.4·10 ⁸	cm Hz ^{1/2} / W
Time constant	5	8	10	ms
Temp. reference voltage ^{b)}		1.4		V
Sensitivity temp. reference		15.5		mV/°C
Sensor gain		4300 or 2150		V/V
Thermopile offset voltage ^{b)}		1.25		V
Field of view		120		°
Operating temperature		-20 ... 120		°C
Storage temperature		-40 ... 120		°C

a) Without filter, T_{obj} = 100°C, DC

b) At T_{amb} = 25°C

Pin No.	Symbol	Description
1	GAIN	Gain factor 4300 (Internal pull up) Gain factor 2150 (VSS/GND on GAIN)
3	VDD	Supply voltage (positive)
4/8	VSS/GND	Ground (0V) / Supply voltage (negative)
6	TPO	Thermopile sensor output voltage
7	TRO	Analog temperature reference output voltage

Filter Types (General List)

Gas	CWL / nm	HPBW / nm	Filter
CH ₄	3300	160	F3.30/160
HC	3375	190	F3.375/190
CO ₂	4260	180	F4.26/180
CO ₂	4300	110	F4.30/110
CO ₂	4430	60	F4.43/60
CO	4640	180	F4.64/180
CO	4640	90	F4.64/90
N ₂ O	4530	85	F4.53/85
NO	5300	180	F5.30/180
(Reference)	3910	90	F3.91/90

Ordering Information

HCM	Heimann Ceramic SMD Module
C	Single channel SMD package
1, 1c, 2	Thermopile chip
2	ASIC analog series
Fx	Application specific filter

E.g.: HCM C1c2 F4.26/180



HCM E222-Series

Dual Channel SMD Thermopile Module

The HCM E222-Series includes a surface mountable dual channel thermopile module optimized for gas analysis. It comes in a leadless ceramic package with a small footprint of 5x5mm² and a low thickness of 1.65mm. The module has two separate thermopile channels with integrated circuits for high-accuracy amplification preset to either 4300 or 2150. The conditioned thermopile sensor voltages and an on-chip linear temperature reference voltage are provided at analog output pins.

One channel typically serves as a reference while the other one can be equipped with filters for specific wavelengths to detect the gas of interest.

The module has a wide operating range from 2.7 V to 5 V and -40°C to 120°C.

Dimensions and PIN-Configuration

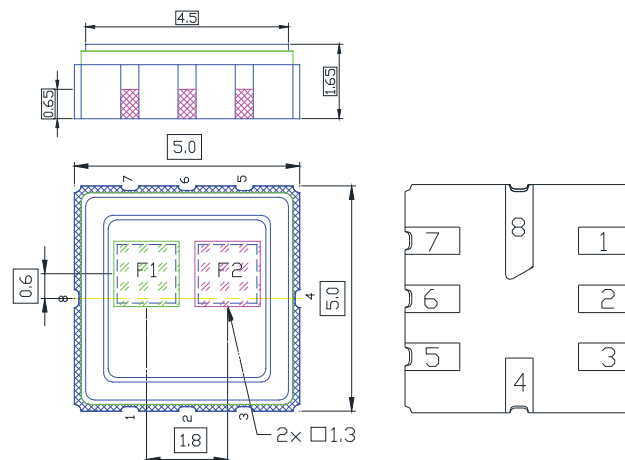

Pin No.	Symbol	Description
1	TPO1	Output thermopile channel F1 Gain 4300 or 2150 by factory
2	VDD	Supply voltage
4/8	VSS/GND	Ground (0V)
3	TRO	Linear temperature reference voltage
5	TPO2	Output thermopile channel F2 Gain 4300 or 2150 by factory

Filter Types (General List)

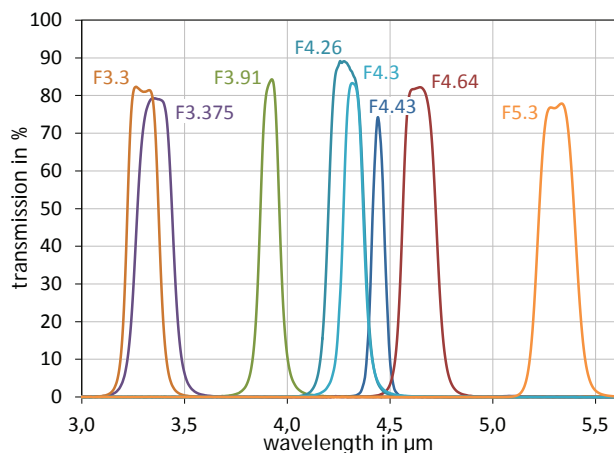

Gas	CWL / nm	HPBW / nm	Filter
CH ₄	3300	160	F3.30/160
HC	3375	190	F3.375/190
CO ₂	4260	180	F4.26/180
CO ₂	4300	110	F4.30/110
CO ₂	4430	60	F4.43/60
CO	4640	180	F4.64/180
CO	4640	90	F4.64/90
N ₂ O	4530	85	F4.53/85
NO	5300	180	F5.30/180
(Reference)	3910	90	F3.91/90

Characteristics

	E222	Unit
Number of channels	2	
Element size	1.2 ²	mm ²
Voltage response ^{a)}	63	Vmm ² /W
Sensitivity ^{a)}	44	V/W
Resistance R _{TP} ^{b)}	84	kOhm
TC of sensitivity ^{b)}	0.02	%/K
Noise ^{b)}	37	nV/Hz ^{1/2}
Detectivity ^{a),b)}	1.4·10 ⁸	cm Hz ^{2/3} /W
Time constant	10	ms
Temp. reference voltage ^{b)}	1.4	V
Sensitivity temp. reference	15.5	mV/°C
Sensor gain	4300 or 2150	V/V
Thermopile offset voltage ^{b)}	1.25	V
Field of view	120	°
Operating temperature	-20 ... 120	°C
Storage temperature	-40 ... 120	°C

a) Without filter, T_{obj} = 100°C, DC
b) At T_{amb} = 25°C

Ordering Information

HCM	Heimann Ceramic SMD Module
E	Dual channel
22	Thermopile chip 2xTP2
2	ASIC analog series
F1, F2	Filter 1 (reference), filter 2 (gas)
Gx	Sensor gain preset G2150 or G4300

E.g.: HCM E222 F3.91/90 F4.26/180 G4300



HID L-Series

Thermopile Digital Modules with Lens Optics

The HID L-Series combines a thermopile sensor chip and ASIC in a small TO-39 metal housing with 4 leads for remote temperature measurements. With an additional optical lens, the sensor facilitates a narrow field of view of 10° at 10% energy points. With an optional lens shade (LS), the field of view can additionally be reduced. This results in a smaller measurement spot with higher signal ratio to ensure improved temperature measurement accuracy.

The module provides a computed temperature output with a temperature resolution of <math><0.1^{\circ}\text{C}</math> either via a digital SMBus interface or by means of PWM, which can easily be converted into an analog voltage. Optional temperature gradient compensation improves thermal shock resistance and ensures high accuracy over a wide sensor and object temperature range.

The sensor can be equipped with several optional features like mentioned lens shade (LS), temperature gradient compensation (TC) or custom filters.

Dimensions and PIN-Configuration

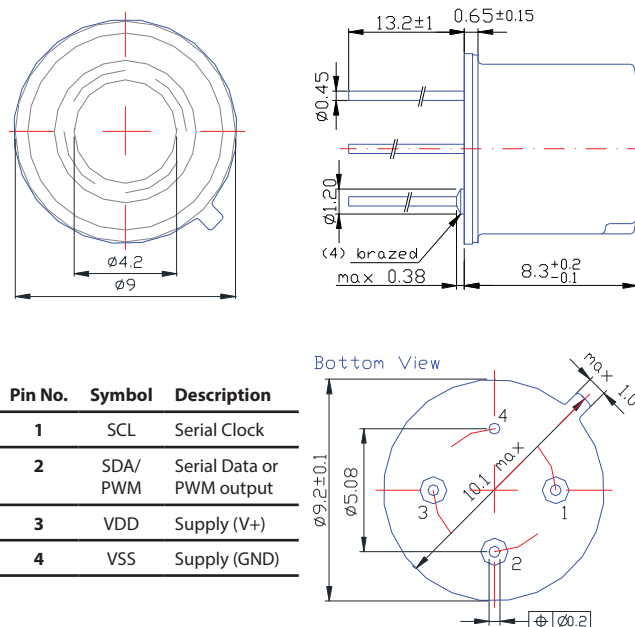

Pin No.	Symbol	Description
1	SCL	Serial Clock
2	SDA/ PWM	Serial Data or PWM output
3	VDD	Supply (V+)
4	VSS	Supply (GND)

Characteristics

	L14 FL5.5 T382	L15 FL5.5 T382	Unit
Supply voltage	5	3	V
Supply current		1	mA
Start up time after POR		150	ms
Object temp. range	-40 ... 382		°C
Refresh rate ASIC ^{a)}	100		ms
Field of view 50% energy	6		degree
Field of view 5% energy	10		degree
Operating temperature	-20 ... 120		°C
Storage temperature	-40 ... 125		°C

a) Temperature output

With lens shade (LS) option:

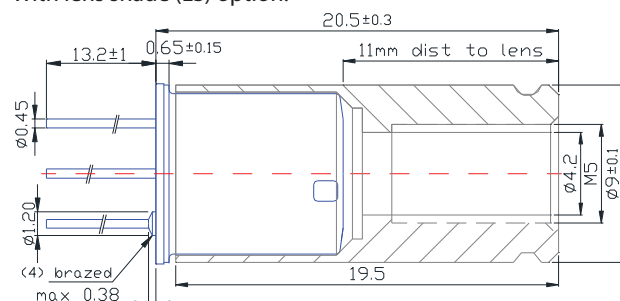

Signal Ratio vs. Distance

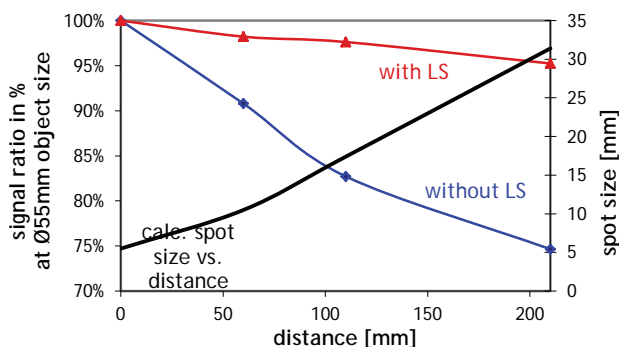

Temperature Performance

		Sensor (Ambient) Temperature [°C]				Temperature Accuracy [°C]
		-40 .. 20	20 .. 60	60 .. 100	100 .. 125	
Object Temperature [°C]	-40 .. 40	±3°C	±2°C	±3°C	±4°C	
	40 .. 100	±2°C	±1°C	±1.5°C	±2.5°C	
	100 .. 150	±3°C	±2°C	±2.5°C	±3°C	
	150 .. 180	±4°C	±2°C	±2.5°C	±3.5°C	
	180 .. 240	±5°C	±3°C	±3°C	±4°C	
	240 .. 300	±5°C	±4°C	±4°C	±5°C	
	300 .. 382	±6°C	±5°C	±5°C	±6°C	

Ordering Information

HID	Heimann Integrated Digital Module
L1	Lens type with Sensor Chip TP1
x	ASIC supply voltage: x=4 → 5V, x=5 → 3V
FL5.5	Lens focal length
LS,TC,PWM	Optional features : lens shade (LS), Temperature gradient compensation (TC), pulse width modulated output, from T1 to T2 (PWM)

E.g.: **HID L14 FL5.5 T200**
HID L15 FL5.5 T380 LS
HID L15 FL5.5 PWM 20/100



HID A-Series

Thermopile Digital Modules

The HID A-Series combines a thermopile sensor chip and ASIC in a small TO-39 metal housing with 4 leads for remote temperature measurements.

This sensor facilitates a wide field of view of 70° with the small TP1 thermopile sensor chip and 100° with the bigger TP2 chip.

The module provides a computed temperature output with a temperature resolution of <math><0.1^{\circ}\text{C}</math> either via a digital SMBus interface or by means of PWM, which can easily be converted into an analog voltage. Optional temperature gradient compensation improves thermal shock resistance and provides high accuracy over a wide sensor and object temperature range. The sensor can be equipped with custom filters or with external apertures to reduce the field of view.

For special requests, please contact Heimann Sensor customer support.

Dimensions and PIN-Configuration

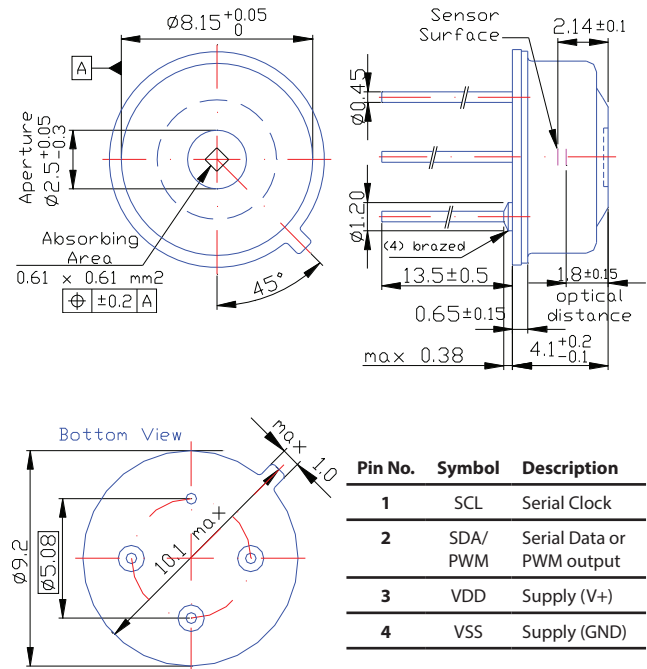

Characteristics

	A1x	A2x	Unit
Supply voltage	3 or 5		V
Supply current	1		mA
Start up time after POR	150		ms
Object temp. range	-40 ... 382		$^{\circ}\text{C}$
Refresh rate ASIC ^{a)}	100		ms
Field of view 50% energy	70	100	degree
Operating temperature	-20 ... 120		$^{\circ}\text{C}$
Storage temperature	-40 ... 125		$^{\circ}\text{C}$

a) Temperature output without TC

Temperature Performance

		Sensor (Ambient) Temperature [$^{\circ}\text{C}$]				
		-40 .. 20	20 .. 60	60 .. 100	100 .. 125	
Object Temperature [$^{\circ}\text{C}$]	-40 .. 40	$\pm 3^{\circ}\text{C}$	$\pm 2^{\circ}\text{C}$	$\pm 3^{\circ}\text{C}$	$\pm 4^{\circ}\text{C}$	Temperature Accuracy [$^{\circ}\text{C}$]
	40 .. 100	$\pm 2^{\circ}\text{C}$	$\pm 1^{\circ}\text{C}$	$\pm 1.5^{\circ}\text{C}$	$\pm 2.5^{\circ}\text{C}$	
	100 .. 150	$\pm 3^{\circ}\text{C}$	$\pm 2^{\circ}\text{C}$	$\pm 2.5^{\circ}\text{C}$	$\pm 3^{\circ}\text{C}$	
	150 .. 180	$\pm 4^{\circ}\text{C}$	$\pm 2^{\circ}\text{C}$	$\pm 2.5^{\circ}\text{C}$	$\pm 3.5^{\circ}\text{C}$	
	180 .. 240	$\pm 5^{\circ}\text{C}$	$\pm 3^{\circ}\text{C}$	$\pm 3^{\circ}\text{C}$	$\pm 4^{\circ}\text{C}$	
	240 .. 300	$\pm 5^{\circ}\text{C}$	$\pm 4^{\circ}\text{C}$	$\pm 4^{\circ}\text{C}$	$\pm 5^{\circ}\text{C}$	
	300 .. 382	$\pm 6^{\circ}\text{C}$	$\pm 5^{\circ}\text{C}$	$\pm 5^{\circ}\text{C}$	$\pm 6^{\circ}\text{C}$	

Ordering Information

HID	Heimann Integrated Digital Module
A	Standard type without lens
1, 2	Sensor Chip (TP1, TP2)
x	ASIC supply voltage: x=4 \rightarrow 5V, x=5 \rightarrow 3V
Fx	Filter type (F5.5, F8-14)
Tx	Temperature measurement range (max. T380)
TC, PWM	Optional features : Temperature gradient compensation (TC), pulse width modulated output, from T1 to T2 (PWM)

E.g.: **HID A15 F8-14 T380**
HID A15 TCT380
HID A25 F5.5 PWM 20/100



HIM Series

Thermopile Integrated Modules for Gas Analysis and Temperature Measurement

The HIM Series includes a thermopile sensor chip (optional TP1, TP1c or TP2) and an analog processing circuit in a small TO-46 metal housing with 4 pins.

The sensor provides at analog outputs the amplified thermopile voltage and an integrated temperature reference. The gain of the high-accuracy amplifier is preset to 4300 or 2150. The sensitivity of the temperature reference is typically 15.5mV/°C.

For gas detection, the sensors can be equipped with narrow band filters with gas specific center wavelength (CWL) and small half power bandwidth (HPBW).

Dimensions and PIN-Configuration

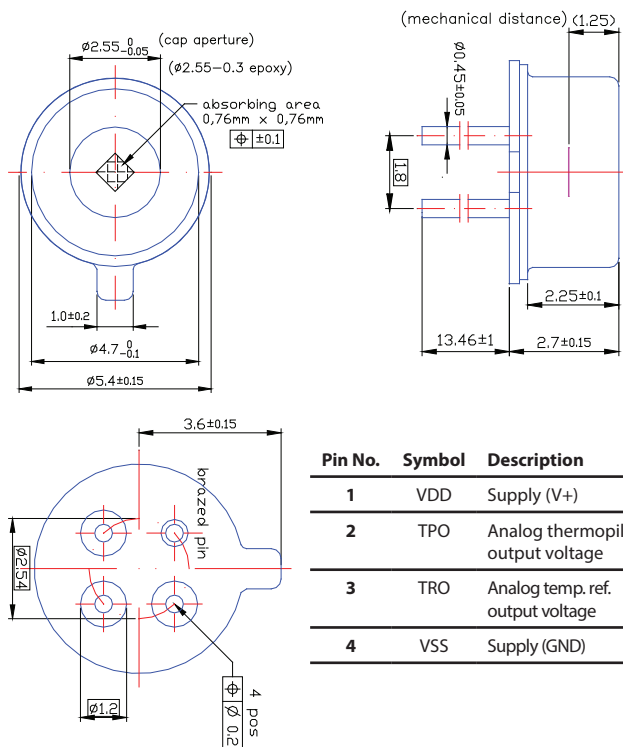

Characteristics

	TP1	TP1c	TP2	Unit
Element size	0.61 ²	0.76 ²	1.2 ²	mm ²
Time constant sensor chip	5	10	10	ms
Sensitivity ^{a)}	58	52	44	V/W
Resistance R _{TP} ^{b)}	86	75	84	kOhm
Voltage response ^{a)}	22	30	63	Vmm ² /W
Field of view	70	80	100	°

a) Without filter, T_{obj} = 100°C, DC
b) At T_{amb} = 25°C

Characteristics Module

	HIM Jx2	Unit
Supply voltage	3 ... 5	V
Supply current	1	mA
Max. startup time after POR	0.5	s
PSRR	>40	dB
Output voltage range	0.15.. (VDD-0.15)	V
Zero input sensor signal	1.25	V
Sensor gain preset	4300 or 2150	V/V
Temp. ref. voltage ^{a)}	1.45	V
Sensitivity temp. ref.	15.5	mV/°C
Field of view ^{b)}	>70	°
Operating temperature	-20 ... 120	°C
Storage temperature	-40 ... 125	°C

a) Tamb = 25°C
b) Depending on the thermopile chip element size

Filter Options Gas Detection

Gas	REF	CO ₂	HC	CO	NO
	F3.91/90	F4.26/180	F3.3/160	F4.64/180	F5.3/180
Filter (CWL/HPBW)		F4.30/110	F3.37/190		
		F4.43/60			

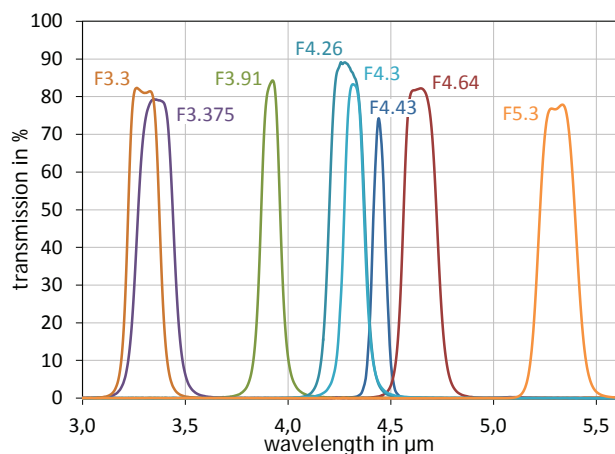

Ordering Information

HIM	Heimann Integrated Module with analog outputs
J	Standard type without optics
1, 1c, 2	Sensor Chip (TP1, TP1c, TP2)
Fx	Filter type (F5.5, F8-14, F4.26/180)
Gx	Gain preset (G= 2150 or 4300)

E.g.: HIM J1C2 F4.26/180 G2150 (gas detection)
HIM J12 F8-14 (temperature sensing)



HMM M-Series

Digital Miniature Modules for Temperature Measurements

The HMM-Series includes Heimann Sensor's smallest thermopile sensor chip and sensor signal conditioning IC in a tiny TO-46 metal housing with 4 leads for remote temperature measurements. It allows computed object temperature or digitized raw voltage readout in SMBus compatible operation with an output range from -5°C to 115°C.

In PWM mode, the temperature output range can be defined with respect to the desired temperature resolution. In SMBus compatible operation, the temperature resolution is <math><0.1^{\circ}\text{C}</math> and the sensor ensures high accuracy over a wide sensor and object temperature range.

The M-package comes with an integrated optical lens which provides a 4:1 distance-to-spot-ratio for smaller measurement spots or larger measurement distances.

Dimensions

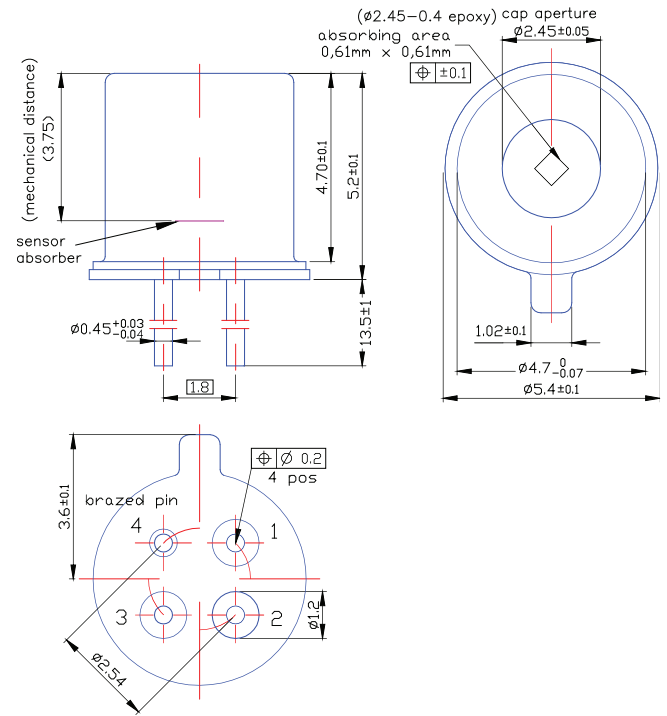

Temperature Performance

		Sensor (Ambient) Temperature [$^{\circ}\text{C}$]			Temperature Accuracy [$^{\circ}\text{C}$]
		-40 .. 0	0 .. 40	40 .. 85	
Object Temperature [$^{\circ}\text{C}$]	-30 .. 0	$\pm 3.5^{\circ}\text{C}$	$\pm 2.5^{\circ}\text{C}$	$\pm 3^{\circ}\text{C}$	
	0 .. 60	$\pm 2.5^{\circ}\text{C}$	$\pm 1.5^{\circ}\text{C}$	$\pm 2^{\circ}\text{C}$	
	60 .. 115	$\pm 3^{\circ}\text{C}$	$\pm 2^{\circ}\text{C}$	$\pm 2.5^{\circ}\text{C}$	

PIN-Configuration

Pin No.	Symbol	Description
1	SDA/PWM	Serial Data or PWM output
2	VDD	Supply (V+)
3	SCL	Serial Clock
4	VSS	Supply (GND)

Parameters Module

	HMM M13	Unit
Supply voltage	3	V
Supply current	1.4	mA
Start up time after POR	150	ms
Object temp. range	-5 ... 115	$^{\circ}\text{C}$
Refresh rate ASIC	100	ms
Operating temperature	-40 ... 85	$^{\circ}\text{C}$
Storage temperature	-40 ... 125	$^{\circ}\text{C}$

Field of View

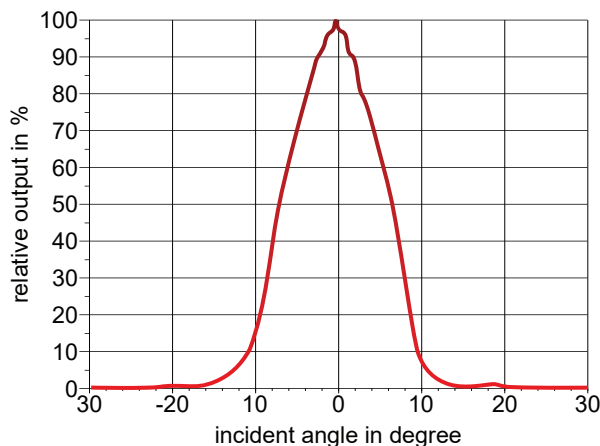



HMM J-Series / N-Series

Digital Miniature Modules for Temperature Measurements

The HMM-Series includes Heimann Sensor's smallest thermopile sensor chip and sensor signal conditioning IC in a tiny TO-46 metal housing with 4 leads for remote temperature measurements. It allows computed object temperature or digitized raw voltage readout in SMBus compatible operation with an output range from -5°C to 115°C.

In PWM mode, the temperature output range can be defined with respect to the desired temperature resolution. In SMBus compatible operation, the temperature resolution is <math><0.1^{\circ}\text{C}</math> and the sensor ensures high accuracy over a wide sensor and object temperature range.

The J-package type comes with a standard cap opening of 2.55mm. The N type has a reduced cap opening of 1.55mm resulting in a smaller field of view of 80°.

Dimensions

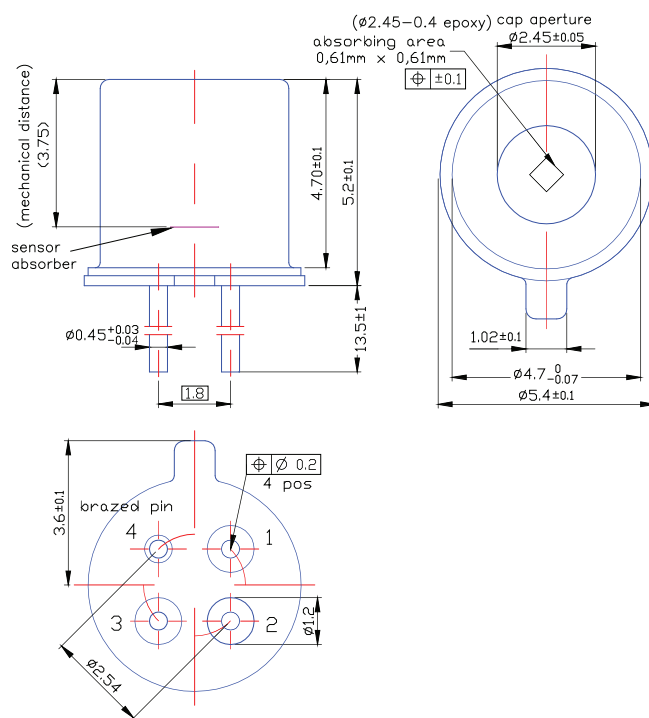

Temperature Performance

		Sensor (Ambient) Temperature [°C]			Temperature Accuracy [°C]
		-40 .. 0	0 .. 40	40 .. 85	
Object Temperature [°C]	-30 .. 0	±3.5°C	±2.5°C	±3°C	
	0 .. 60	±2.5°C	±1.5°C	±2°C	
	60 .. 115	±3°C	±2°C	±2.5°C	

PIN-Configuration

Pin No.	Symbol	Description
1	SDA/PWM	Serial Data or PWM output
2	VDD	Supply (V+)
3	SCL	Serial Clock
4	VSS	Supply (GND)

Parameters Module

	HMM J13 / N13	Unit
Supply voltage	3	V
Supply current	1.4	mA
Start up time after POR	150	ms
Object temp. range	-15 ... 115	°C
Refresh rate ASIC	100	ms
Field of view 50% energy	100 / 80	°
Operating temperature	-40 ... 85	°C
Storage temperature	-40 ... 125	°C

Characteristics Module

	TP1	TP1c	TP2	Unit
Element size	0.61 ²	0.76 ²	1.2 ²	mm ²
Time constant sensor chip	5	8	10	ms
Sensitivity ^{a)}	58	52	44	V / W
Voltage response ^{a)}	22	30	63	V mm ² / W
Resistance R _{TP} ^{b)}	86	75	84	kOhm

a) Without filter, T_{obj} = 100°C, DC
b) At T_{amb} = 25°C

APPLICATION NOTES

- NDIR Measurements**
- Infrared Measurements**

Intro

Heimann Sensor components are exceptionally suitable to measure the concentration of several gases by NDIR method. Steady improvements on existing products as well as constantly developing innovations, puts us in the position of being able to provide best support to all our customers. This note gives an overview on the physics, available components and the principles of measurement.

Physics

The nondispersive infrared (NDIR) gas detection is based on the absorption of infrared radiation, which is shown by many polyatomic or heterodimer diatomic gases. For example CO₂ gas absorbs IR radiation at 4.26µm wavelength. The detected radiation intensity at this wavelength decreases if the concentration of CO₂ increases between source and detector. The extent of absorption mainly depends on the absolute number of CO₂-molecules between radiation source and detector. Accordingly the given concentration for a measured intensity is a function of the cell length and the gas density.

The law of Lambert and Beer describes the transmitted intensity I in relation to the initial intensity I_0 , where k is a specific absorption coefficient, c is the concentration and s is the absorption path length:

$$I = I_0 \cdot e^{-k \cdot c \cdot s} \quad (1)$$

Note: In equation (1) the concentration c refers to the volume, not to the total number of molecules. As the gas density is a function of the given pressure, the concentration in ppm is also pressure dependent.

Basic Set-Up

The basic set-up consists of an IR-source, the gas cell, an IR filter matching the absorption line of interest and the IR-Sensor (see Figure 1).

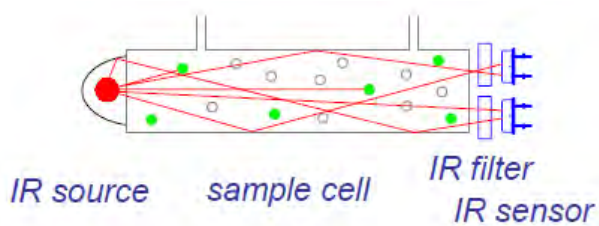

fig. 1 example set-up with dual channel sensor

Optics to focus the radiation can be integrated, as well as measures to increase the reflecting ratio on inner walls. The gas cell must ensure access to free flowing gas, but it is not strictly recommended to have a single path. A design increasing the path length by folding the rays is also possible.

Application Note NDIR-Measurement

Rev.1: 2013.10.02, Hu, MaS



Sensor Components

Main part of the set-up is the sensor with integrated optical filter(s). A single sensor could be used as well as a dual-channel sensor to manage source variations and minimize aging effects.

Also available are 4-channel-sensors for multi-gas-detection (see figure 2). The different channels vary in the use of diverse filters, according to the specific absorbing wavelength of the gases to be detected.

One channel without sensitivity to any of the gases can be used as reference.

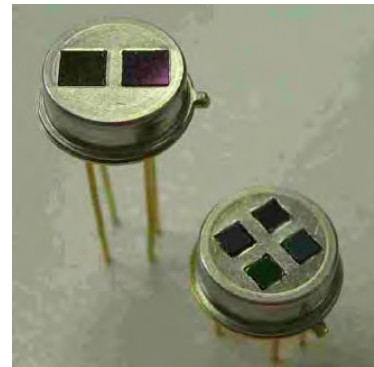

fig. 2 Dual and 4-channel Sensor HTS E21 and HTS Q21

Thermopile infrared sensors create a voltage signal (U) proportional to the received radiation. The signal is generated by a difference of temperature of the object (T_{Object}) and the sensors own temperature (T_{amb}). Equation (3) describes the basic function, where K is an apparatus constant and the exponent n depends on the actual filter characteristics. n reaches a theoretically maximum of $n=4$ for a perfect “black” characteristic and unlimited wavelength.

$$U = K \cdot (T_{\text{Object}}^n - T_{\text{amb}}^n) \quad (2)$$

All multichannel sensors tend to crosstalk effects, where sensor chips might receive radiation passing through a different close-by filter. To avoid these effects all Heimann multichannel sensors are equipped with an optical barrier working as crosstalk suppression.

The following table gives an overview for the many different detector options available from Heimann Sensor.

type	size	TP Chip	channels	integrated amplifier	output
HMS J21 F1	TO46	TP2	1	N	analog
HTS A21 F1	TO39	TP2	1	N	analog
HTS E21 F1/F2	TO39	TP2	2	N	analog
HTS Q21 F1/F2/F3/F4	TO39	TP2	4	N	analog
HIM J1C2 F1 G4300	TO46	TP1C	1	Y	analog
HIS A22 F1 G4300	TO39	TP2	1	Y	analog
HID A2x F1 G100	TO39	TP2	1	Y	digital
HIS E222 F1 F2 G4300	TO39	TP2	2	Y	analog
HID E22x F1 F2 G100	TO39	TP2	2	Y	digital
HCS C21 F1	SMD3.8x3.8	TP2	1	N	analog
HCM C1C2 F1	SMD3.8x3.8	TP1C	1	Y	analog
Plus many different highest detectivity pyroelectric sensors	TO39 TO8	various element sizes	1, 2, 4	voltage mode	analog

Note: F1 to F4: filter matching infrared absorption lines of specific gases or reference filter (recommended filters in below list)

Optical Filters

The following filter specifications are available at Heimann Sensor.

Gas	CWL /nm	Tol /%	Tol /nm	HPBW /nm	HPBW Tol /nm
CH ₄	3300	±1	±33	160	±20
HC	3375	±1	±34	190	±20
CO ₂	4260	±1	±43	180	±20
CO ₂	4270	±1	±43	90	±20
CO ₂	4430	±1	±44	60	±10
CO	4640	±1	±46	180	±20
Ref	3910	±1	±39	90	±20

Further filters can be sourced on demand if the customer provides the specification in terms of center wavelength, half power bandwidth and blocking.

If Heimann Sensor is asked to do the dicing of consigned filter material, we need to know about the substrate material so that we can calculate the dicing cost. The preferred thickness is 0.5 mm.

If a customer wants to consign diced filter windows, first we need to agree on the appropriate window specification.

The filter transmission curves will vary with temperature and angle of incidence.

If the angle deviates from normal condition, the filter shifts to shorter wavelength. Equation (3) describes this dependency.

$$\lambda_{\Theta} = \lambda_0 \cdot \frac{\sqrt{n^2 - \sin^2 \Theta}}{n} \quad (3)$$

with λ_0 being the specific wavelength, n the index of refraction and Θ being the angle of incidence.

Sources

Besides infrared sensors Heimann Sensor offers infrared lamps and infrared radiation sources to be used together with our detectors in NDIR gas detection.

The infrared lamps HSL 5/115, HSL 5/60 or HSL 5/115/S are low cost and reliable IR sources with a long lifetime. They can be used for wavelengths up to approximately 4.5 μm and they can be operated in DC or AC mode. Typical operating conditions are 5 V and 115 mA respectively 60 mA. The version "S" has the leads fixed in a small socket.

The infrared sources are micro-machined thermal infrared emitters that allow fast electrical modulation for wavelengths range up to 16 μm . A patented technology enables manufacturing of sources with true black body characteristics and very high emissivity combined with low power consumption and long life time. The sources are available with and without a concentrating reflector mirror. The standard version comes without window in a TO39 package.

IR sources in TO46 or even micro TO packages are also available.

Measurement Method

To make sure to process only source data, the emission of the source should be pulsed, generating time based sequences with a well defined frequency. To avoid thermal drifts, time of emission should be short to ensure a sufficient cool down time. Figures 3&4 show an example: a pulse sequence of 8 pulses, 140 ms/pulse at 1.33 Hz of the source and the corresponding received radiation of the sensor.

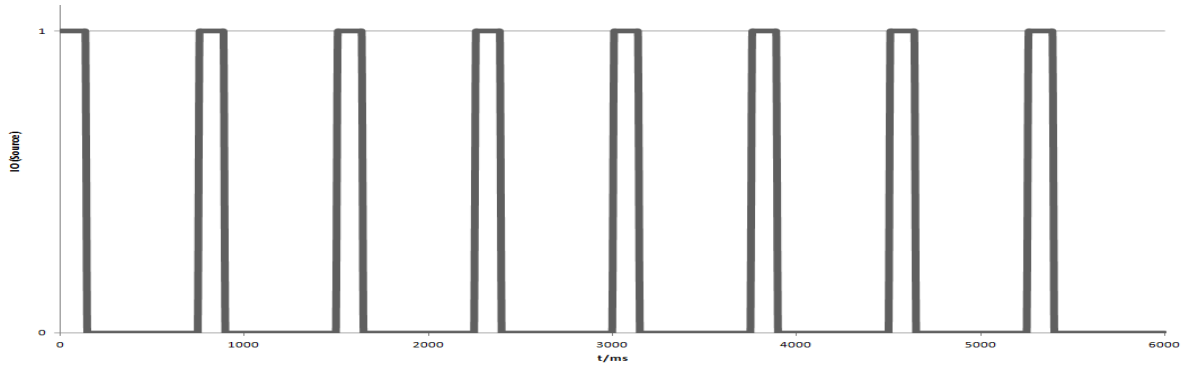

fig. 3 Pulse sequence of the source

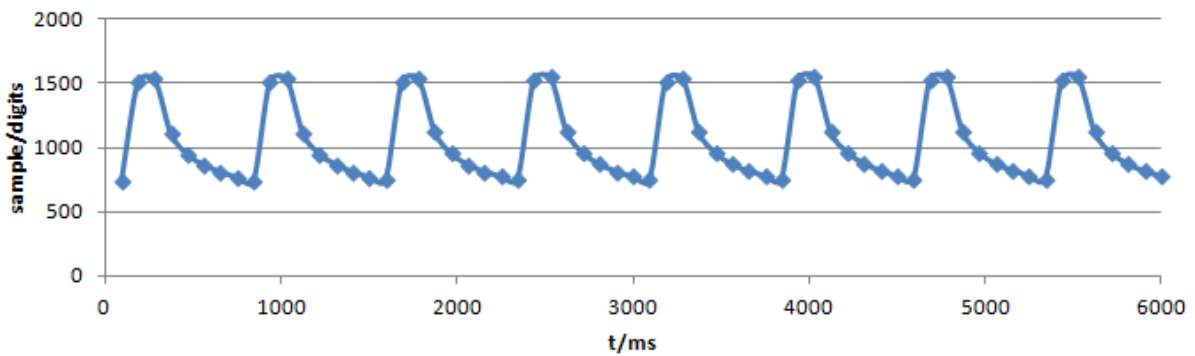

fig. 4 Sample sequence of the sensor

Reference channel and gas-sensitive channels can be recorded simultaneously. Data could be frequency-analyzed with an FFT (fig. 5&6).

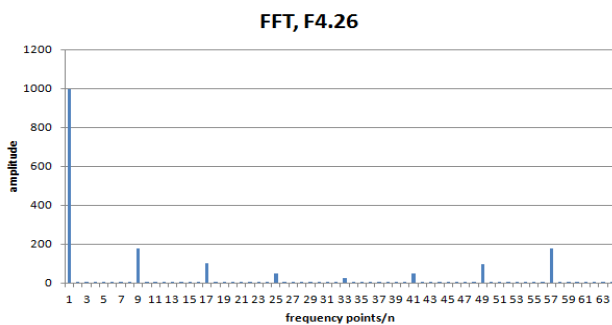

fig. 5 FFT of a CO₂ sensitive channel

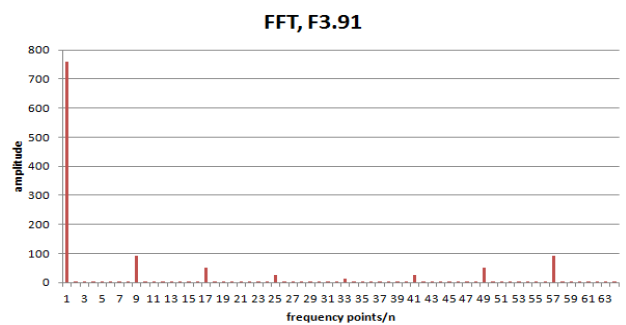

fig. 6 FFT of the reference channel

In general there are two possible ways to evaluate the data. Either do take the quotient or the difference of gas sensitive and reference channel.



Infrared Measurement

Application Notes

Every object emits electromagnetic radiation, which wavelength spectrum is dependent on its temperature. For an object without “color”, which means that no wavelength is selectively emitted or absorbed, the radiation spectrum is completely determined by the temperature alone. In this case, the total radiation power P_{obj} emitted by an object of temperature T_{obj} can be expressed as

$$P_{obj} = \sigma \cdot \epsilon \cdot (T_{obj})^4$$

with σ being the Stefan-Boltzmann constant and ϵ the so-called emission factor (or emissivity) of the object. In the ideal case ϵ has the value 1 (black body). For many substances the emission factor lies in the range between 0.85 to 0.95. The above equation is called the Stefan-Boltzmann law. It integrates the total quantity of radiation over all wavelength.

The *net* power P_{rad} received by the thermopile is related to the object temperature T_{obj} and to the temperature of the thermopile chip itself. This value is generally referred as T_{amb} , the ambient temperature.

Therefore the total heat power P_{rad} received from the object at temperature T_{obj} is given to

$$P_{rad} = K \cdot (\epsilon_{obj} \cdot T_{obj}^4 - \epsilon_{abs} \cdot T_{amb}^4)$$

The empirical factor K is a constant device factor.

The thermopile sensor delivers an output signal proportional to the heat flux. The heat balance equation is the basis of any quantitative temperature measurement ($S \rightarrow$ voltage sensitivity).

$$U_{TP} = S \cdot P_{rad} = S \cdot K \cdot (\epsilon_{obj} \cdot T_{obj}^4 - \epsilon_{abs} \cdot T_{amb}^4)$$

It describes that the output voltage is a function of the object and the ambient temperature. For a fixed ambient, the theoretical output voltage of the thermopile chip is proportional to T_{obj}^4 . The T^4 -dependence is only valid, if the sensor senses the whole electromagnetic spectrum with the same sensitivity.

Since in all practical situations the thermopile sensor never senses over all wavelengths with the same sensitivity, the pure T^4 -dependence will rarely be seen. The real dependency can be better described by a polynomial regression of many polynomial factors and coefficients.

The output voltage also varies with the ambient temperature. Any IR temperature measurement system needs therefore to compensate this effect.

There are two possible ways to realize the ambient temperature compensation of the output signal. The analog way by employing an analog circuit. The circuit is designed in a way, that a voltage is generated, which matches exactly the loss or gain in output voltage due to any ambient temperature change.

For high accuracy applications a digital (numerical) calculation method is needed. In this case, the two signals, thermopile voltage and temperature reference signal are derived separately and fed into a microcontroller system, where the necessary calculations are made. The ambient temperature compensation can be performed using look-up tables or polynomial regression equations as a function of the ambient temperature, thermopile output and as result the object temperature. The calculation is related to a defined emissivity. The emissivity variation can be considered by a factor.

Example Amplifier Circuits

Common Amplifier

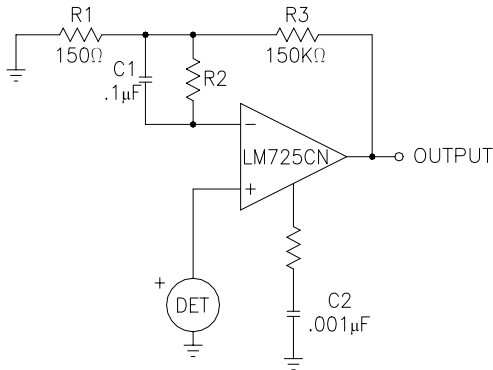

Micro Power Amplifier

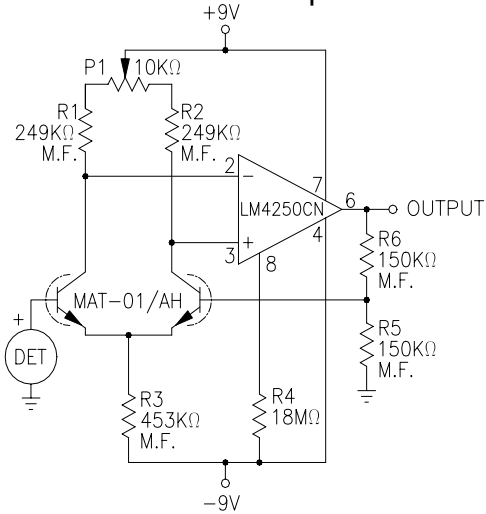

LM4250CN NATIONAL SEMICONDUCTOR AVAILABLE FROM DIGIKEY
R2 IS SELECTED TO MATCH DETECTOR RESISTANCE

MAT-01/AH ANALOG DEVICES AVAILABLE FROM NEWARK ELECTRONICS
LM4250CN NATIONAL SEMICONDUCTOR AVAILABLE FROM DIGIKEY
M.F. = METAL FILM RESISTOR

Modulated Signal Rectifier For 10Hz (Full Wave)

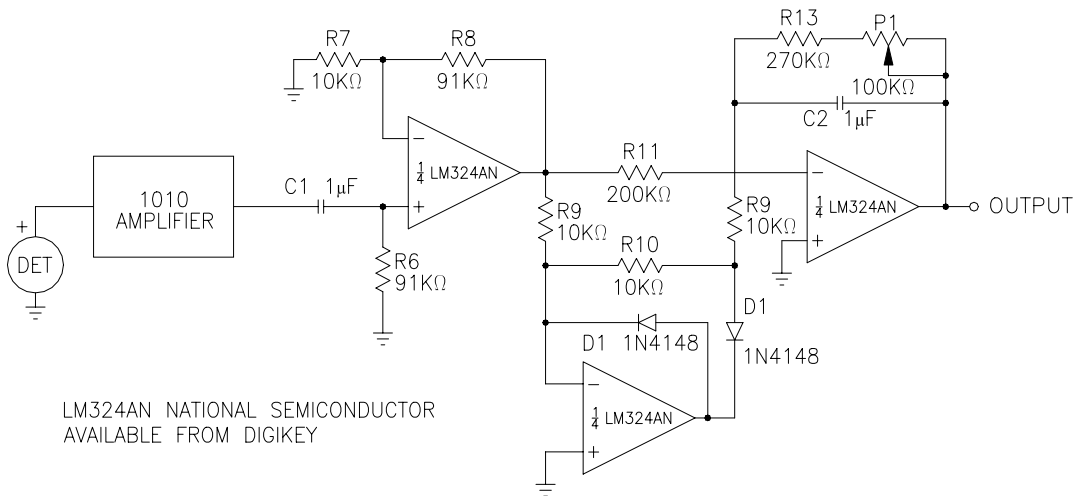

LM324AN NATIONAL SEMICONDUCTOR AVAILABLE FROM DIGIKEY

Equivalent Circuit Single Element Thermopile Detector

R = DETECTOR RESISTANCE
C = THERMAL CAPACITANCE
V = VOLTAGE SOURCE

