

255nm UVC LED

- **SMD**
 - **medium & high power**
- **Chip on Board (COB)**
- **3x3 and 4x4 Arrays - COB**
- **Light Bars (12x1)**

 **Boston**Electronics

www.boselec.com

uv@boselec.com

shop.boselec.com

617.566.3821

255nm UV LED Product Line

5252 Series Mid Power SMD

- Single-Chip Package
- Dimensions: 5.2mm x 5.2mm
- Thermal Resistance: 0.9°C/W

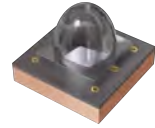

Part Number	Wavelength (nm)	Forward Current (mA)	Optical Output (mW)	Forward Voltage (V)	Viewing Angle (degree)
VS5252C48L6-255-V1	255	500	51	5.9	60°

7272 Series High Power SMD

- Four-Chip Package
- Dimensions: 7.2mm x 7.2mm
- Thermal Resistance: 0.32°C/W

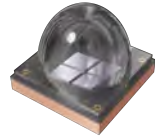

Part Number	Wavelength (nm)	Forward Current (mA)	Optical Output (mW)	Forward Voltage (V)	Viewing Angle (degree)
VS7272C48L6-255-V1	255	1000	200	11.8	60°

1X1 Series Mid Power COB

- Single-Chip Module
- Dimensions: 15mm x 15mm
- Thermal Resistance: 0.9°C/W



Part Number	Wavelength (nm)	Forward Current (mA)	Optical Output (mW)	Forward Voltage (V)	Viewing Angle (degree)
VC1X1C48L6-255-V1	255	500	51	5.9	60°

2X2 Series High Power COB

- Four-Chip Module
- Dimensions: 20mm x 20mm
- Thermal Resistance: 0.32°C/W

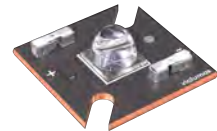

Part Number	Wavelength (nm)	Forward Current (mA)	Optical Output (mW)	Forward Voltage (V)	Viewing Angle (degree)
VC2X2C48L6-255-V1	255	1000	200	11.8	60°

255nm UV LED Product Line

12X1 Series Light Bar COB

- Twelve-Chip Module
- Dimensions: 304mm x 20mm
- Thermal Resistance: 0.075°C/W



Part Number	Wavelength (nm)	Forward Current (mA)	Optical Output (mW)	Forward Voltage (V)	Viewing Angle (degree)
VC12X1C48L6-255-V1	255	1000	610	35.4	60°

3X3 Series High Density COB

- Nine-Chip Module
- Dimensions: 30mm x 30mm
- Thermal Resistance: 0.1°C/W

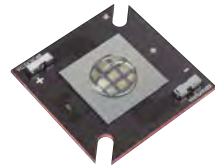

Part Number	Wavelength (nm)	Forward Current (mA)	Optical Output (mW)	Forward Voltage (V)	Viewing Angle (degree)
VC3X3C48L9-255-V1	255	1500	400	17.7	90°

4X4 Series High Density COB

- Sixteen-Chip Module
- Dimensions: 30mm x 30mm
- Thermal Resistance: 0.06°C/W

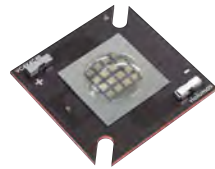

Part Number	Wavelength (nm)	Forward Current (mA)	Optical Output (mW)	Forward Voltage (V)	Viewing Angle (degree)
VC4X4C48L9-255-V1	255	2000	660	23.6	90°

VS5252C48L6-255-V1 | Mid Power 255nm SMD

The VS5252C48L6-255-V1 is a mid power surface-mount-device (SMD) UV LED with a peak wavelength of $255\pm 5\text{nm}$. The SMD is structured with a patented 3-PAD LED Flip Chip mounted onto a copper-based Pillar substrate to boost output efficiency and reduce the thermal resistance. The VS5252C48L6-255-V1 is packaged in a single-chip structure with a 60° fused silica lens and is ideal for mid power UV applications.



Features & Benefits

- Dimensions: 5.2mm x 5.2mm x 3.3mm
- Typical Peak Wavelength: 255nm
- Equipped with a 60° fused silica lens*
- Integrated thermal technology in LED chip and substrate for lowest thermal resistance & reduced thermal decay

**VS5252C48L6-255-V1 is also available with 30° , 120° , and 135° lenses. Please contact Violumas for specifications regarding alternative LED beam angles.*

Electro-Optical Characteristics at $I_F = 500\text{mA}$ and $T_A = 25^\circ\text{C}$

Parameter	Symbol	Unit	Min	Typical	Max
Peak Wavelength	λ_p	nm	250	255	260
Forward Voltage	V_F	V	5.6	5.9	6.4
Radiant Flux	P_O	mW	35	51	75
Full Width of Half Magnitude	$\Delta\lambda$	nm	-	13	-
Radiant Angle	$2\Phi_{1/2}$	Degree	-	60	-
Thermal Resistance, Junction to Solder Joint	$R_{th}(J-S)$	$^\circ\text{C}/\text{W}$	-	0.9	-

Peak Wavelength Tolerance: $\pm 3\text{nm}$; Forward Voltage Tolerance: 0.1V ; Radiant Flux Tolerance: $\pm 10\%$

Absolute Maximum Ratings

Parameter	Symbol	Unit	Value
Forward Current	I_F	mA	700
Reverse Voltage	V_R	V	5
Power	P_D	W	4.8
Junction Temperature	T_J	$^\circ\text{C}$	90
Operating Temperature	T_{OPR}	$^\circ\text{C}$	-30 ~ 85
Storage Temperature	T_{STG}	$^\circ\text{C}$	-40 ~ 100

Note: Operating the LED at or above the listed absolute maximum ratings may affect device reliability and result in permanent LED failure.

Spectral Output

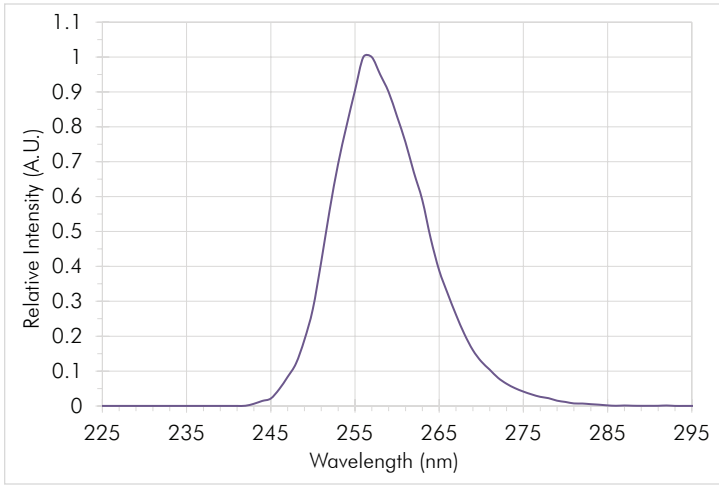

Radiation Pattern

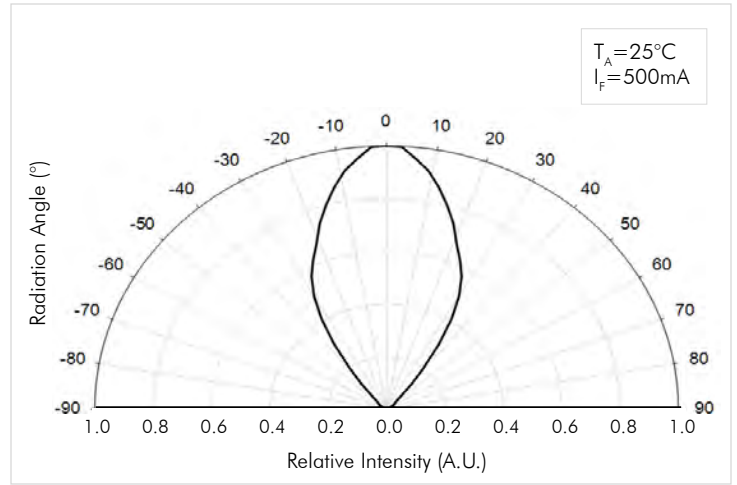

Forward Current vs. Relative Radiant Flux

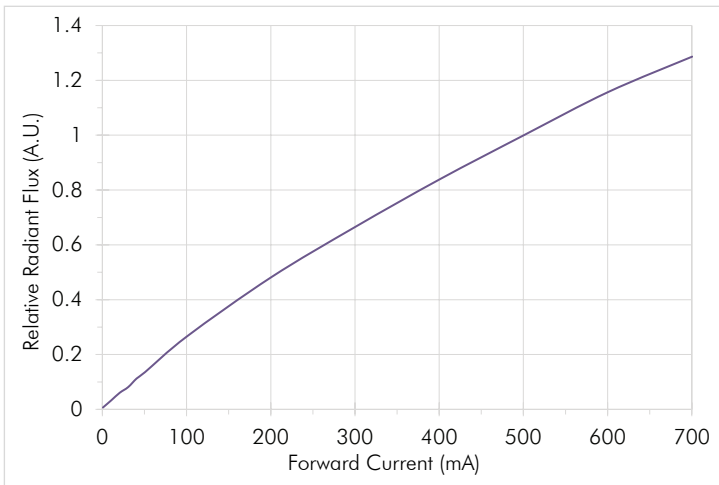

Forward Voltage vs. Forward Current

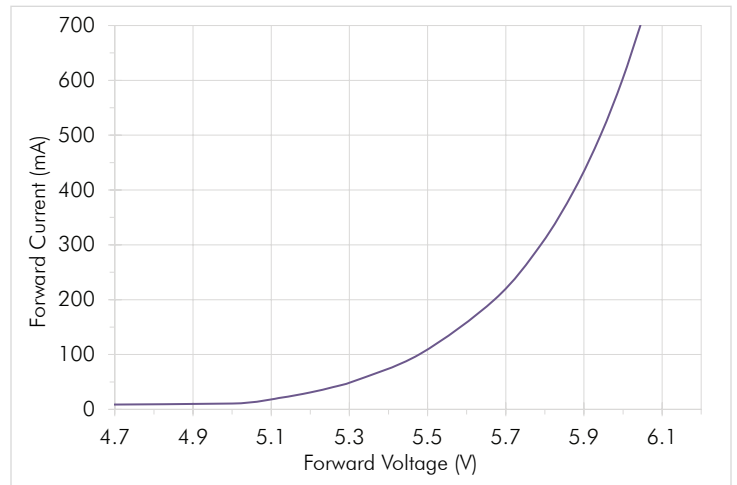

Mechanical Dimensions

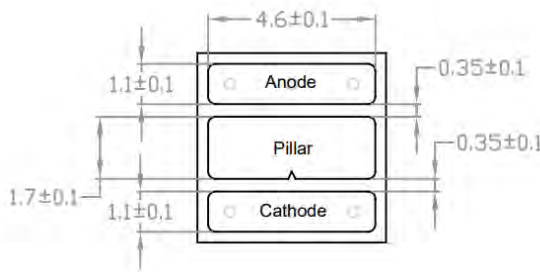
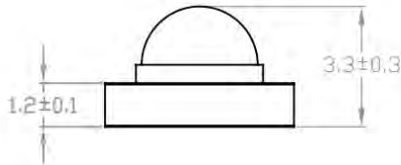
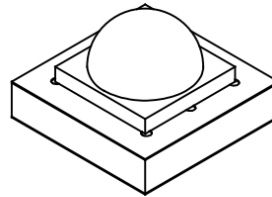
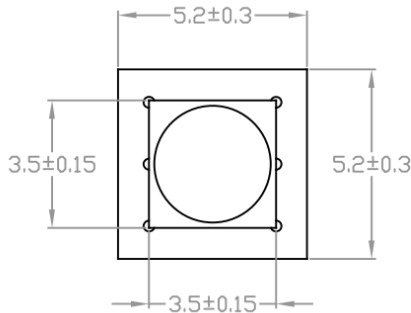

Recommended Solder Pad

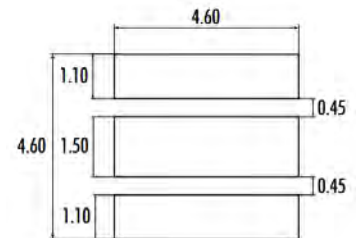

Note: The maximum offset (tolerance) for lens alignment over the LED is 0.2mm.

Reel Packaging Specifications

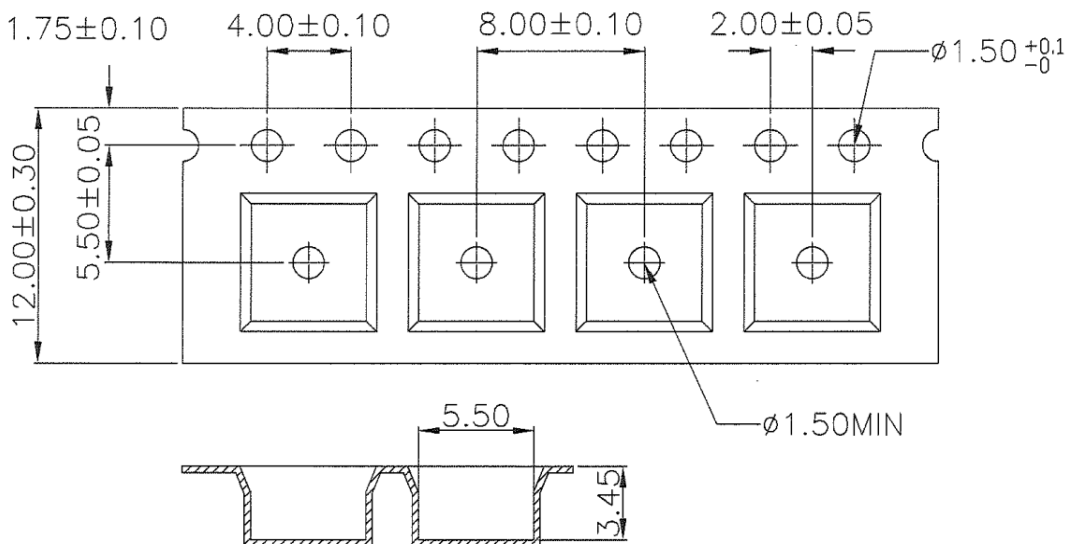

Each reel is loaded with 350 units and includes a leader section (200mm) and a trailer section (200mm) with empty pockets. The diameter of the reel is 177.8mm. Devices are placed with the anode to the left.

Soldering Guidelines

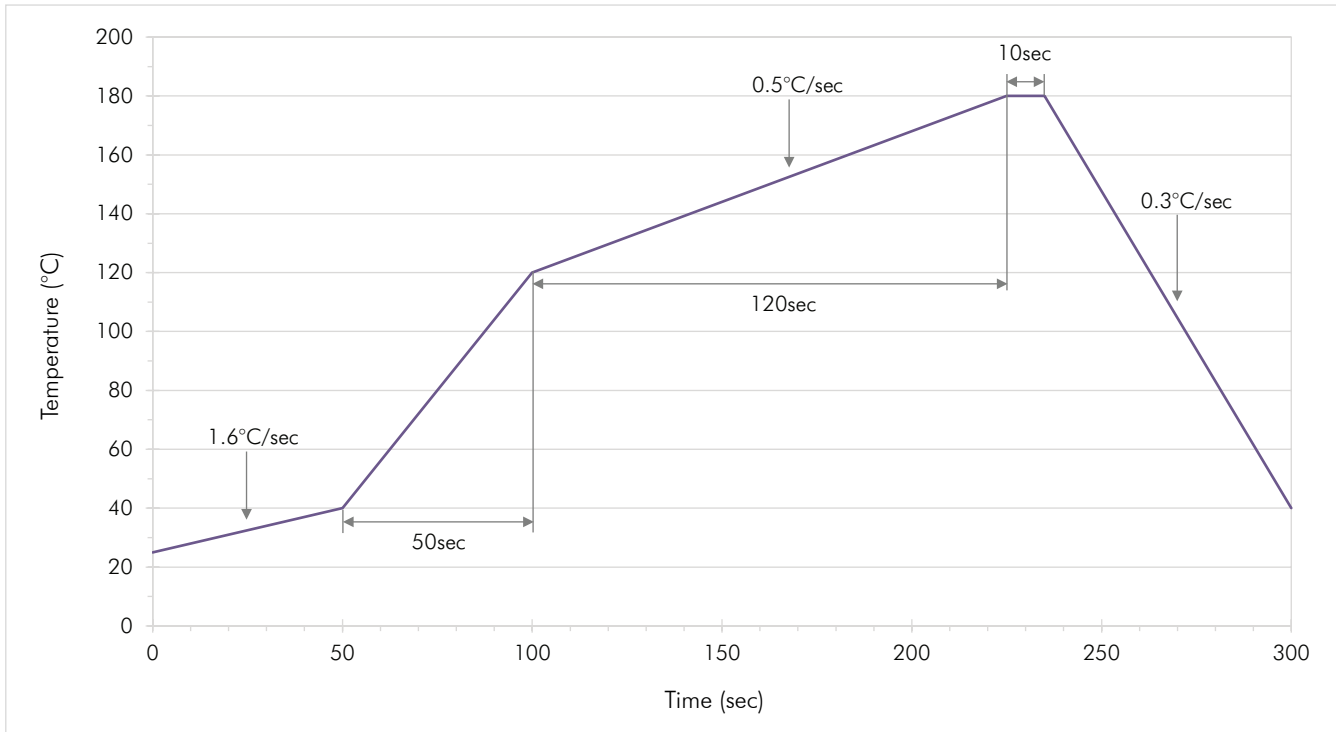

Reflow Profile Feature	Standard Parameters
Preheat Temperature Minimum	40°C
Preheat Temperature Maximum	120°C
Preheat Time	50 sec
Preheat Ramp-Up Rate	1.6°C/sec
Peak Temperature	±5°C
Time from Preheat Maximum Temperature to Peak Temperature	120 sec
Ramp-Up Rate from Maximum Temperature to Peak Temperature	0.5°C/sec
Time Within 5°C of Peak Temperature	5 sec
Maximum Time Maintained at Peak Temperature within Tolerance	10 sec
Ramp-Down Rate	3°C/sec

Handling & Usage Precautions

- Exhibit extreme care when handling LEDs. Do not touch the LED with bare hands as doing so may contaminate and affect the optical characteristics of the LED. When using tweezers, do not apply excessive force, especially to the glass lens. Do not drop the LED as doing so may cause product damage.
- Ensure that electrostatic discharge specifications are followed. Static electricity and surge voltages may cause product damage. Proper electrostatic discharge protection equipment, working machinery, and protected mounting equipment are recommended.
- Do not expose the LEDs to volatile organic compounds as well as hazardous, acidic, and corrosive substances during storage and operation to avoid product damage.
- Do not apply excess mechanical force and vibration while handling the product.
- Do not expose the product to sudden changes in temperature, high humidity levels, and condensation.
- Ensure that the PCB is suitable for the product and be wary of LED placement and possible PCB warpage.
- To avoid fault issues, do not couple any electrical wires to the metal substrate of the MCPCB or COB. If any electrical wires from the power source have contact with the MCPCB's metal base under power ON conditions, permanent damage may occur due to inner arcing within the LED structure.
- Avoid grounding of the LED copper substrate. Transient charges can propagate from the ground to the heatsink and finally to the copper substrate of the LED unit and damage the dielectric layer from ground charges. An insulator must be placed between the heatsink and the benchtop to avoid transient charge propagation from the ground.

Storage Precautions

- Perform soldering as soon as the moisture-proof packaging is opened.
- After the storage duration has exceeded the recommended time, products may need to be baked before soldering.
- Do not expose the product to sudden changes in temperature, high humidity levels, and condensation. It is recommended to store all products in a controlled environment under 30°C free of dust.
- Please consult the Violumas engineering team for further information on storage precautions.

Eye Safety Precautions

- Avoid exposure to UV light during LED operation. Do not look directly into the UV light during LED operation. Do not look directly into the UV light during optical measurements even through optical instruments. Protect the body, skin, and eyes with UV protective equipment.
- Attach warning labels on all products and systems that use UV LEDs.

Cleaning Precautions

- Do not use brushes or organic solvents for cleaning the LEDs.
- Perform electrical and optical measurements before and after cleaning to ensure optimal performance.

Static Electricity Precautions

- Ensure that equipment and machinery are properly grounded.
- Anti-electrostatic attire (wristbands, gloves, footwear, etc.) is recommended.
- Damage inspection is recommended while performing characteristics inspection of LEDs.

Disclaimers

Violumas is not responsible for any damages that result from inaccurate use of the recommended guidelines. The information compiled in this document is a result of careful review of reference materials and reliable sources. Violumas does not make any claims regarding warranty or guarantee. It is recommended that each customer consults the Violumas engineering team before engaging Violumas products in extreme applications where the failure of the LED and damage to human health may be possible. Each user assumes full responsibility for determining the suitability of the use of Violumas products in various applications. Disassembling Violumas products without consent is prohibited. No part of these documents may be reproduced in any form without prior written permission from Violumas. Please note that the data presented in this document is measured from the use of exclusive Violumas patented products - the 3-PAD LED Flip Chip and the Pillar MCPCB.

VS7272C48L6-255-V1 | High Power 255nm SMD

The VS7272C48L6-255-V1 is a high power surface-mount-device (SMD) UV LED with a peak wavelength of $255\pm 5\text{nm}$. The SMD is structured with four patented 3-PAD LED Flip Chips mounted onto a copper-based Pillar substrate to boost output efficiency and reduce the thermal resistance. The VS7272C48L6-255-V1 is packaged in a four-chip structure with a 60° fused silica lens and is ideal for high power UV applications.

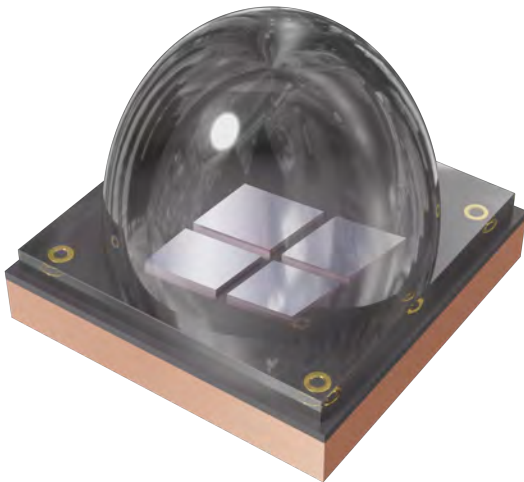

Features & Benefits

- Dimensions: 7.2mm x 7.2mm x 6.0mm
- Typical Peak Wavelength: 255nm
- Equipped with a 60° fused silica lens*
- Integrated thermal technology in LED chips and substrate for lowest thermal resistance & reduced thermal decay

**VS7272C48L6-255-V1 is also available with a 135° lens.*

Please contact Violumas for specifications regarding alternative LED beam angles.

Electro-Optical Characteristics at $I_F = 1000\text{mA}$ and $T_A = 25^\circ\text{C}$

Parameter	Symbol	Unit	Min	Typical	Max
Peak Wavelength	λ_p	nm	250	255	260
Forward Voltage	V_F	V	11.2	11.8	12.8
Radiant Flux	P_O	mW	145	200	270
Full Width of Half Magnitude	$\Delta\lambda$	nm	-	13	-
Radiant Angle	$2\Phi_{1/2}$	Degree	-	60	-
Thermal Resistance, Junction to Solder Joint	$R_{th}(J-S)$	$^\circ\text{C}/\text{W}$	-	0.32	-

Peak Wavelength Tolerance: $\pm 3\text{nm}$; Forward Voltage Tolerance: 0.1V ; Radiant Flux Tolerance: $\pm 10\%$

Absolute Maximum Ratings

Parameter	Symbol	Unit	Value
Forward Current	I_F	mA	1400
Reverse Voltage	V_R	V	10
Power	P_D	W	19
Junction Temperature	T_J	$^\circ\text{C}$	90
Operating Temperature	T_{OPR}	$^\circ\text{C}$	-30 ~ 85
Storage Temperature	T_{STG}	$^\circ\text{C}$	-40 ~ 100

Note: Operating the LED at or above the listed absolute maximum ratings may affect device reliability and result in permanent LED failure.

Spectral Output

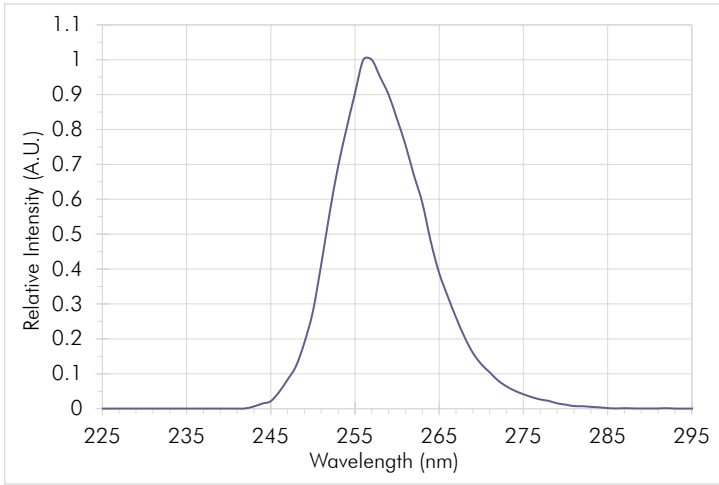

Radiation Pattern

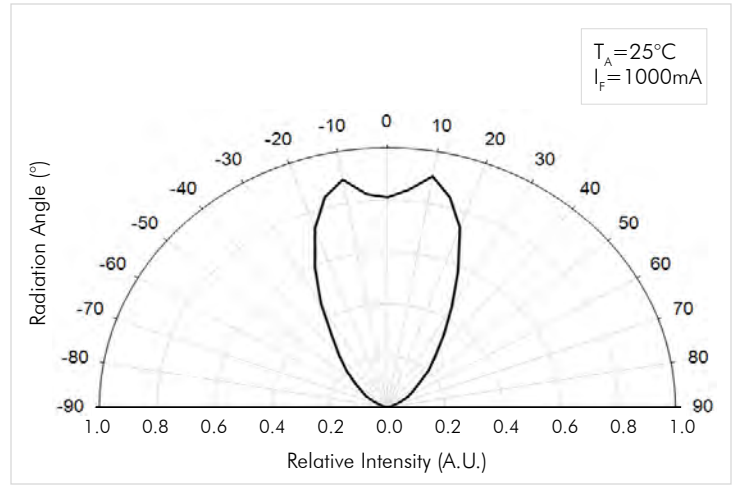

Forward Current vs. Relative Radiant Flux

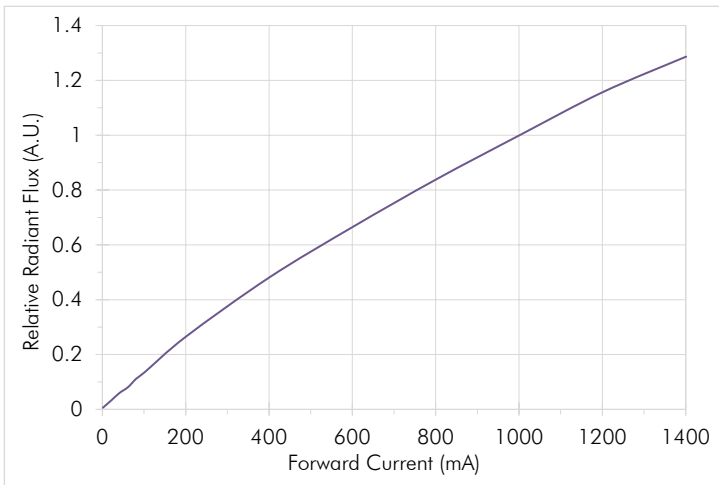

Forward Voltage vs. Forward Current

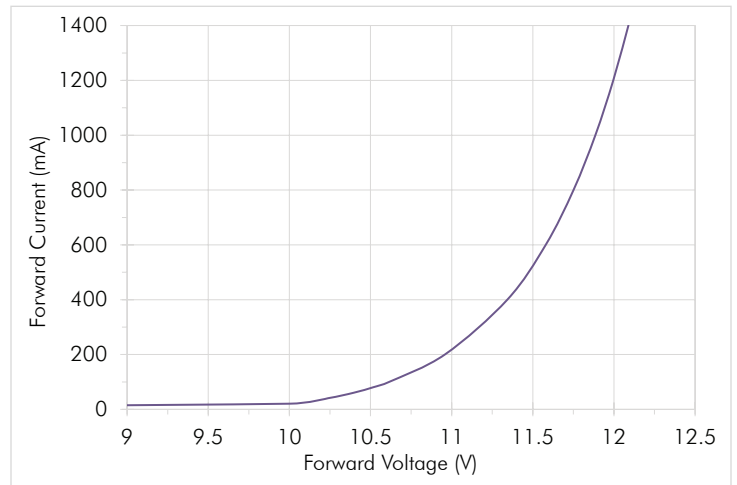

Mechanical Dimensions

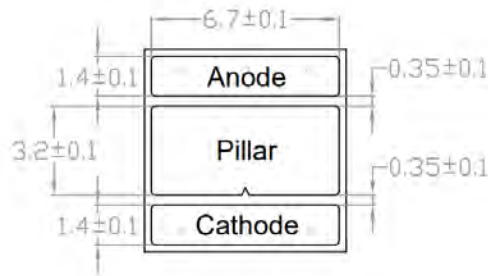
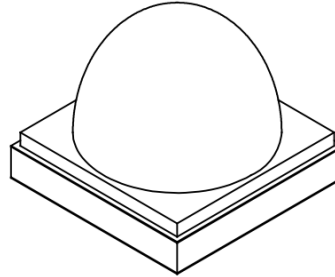
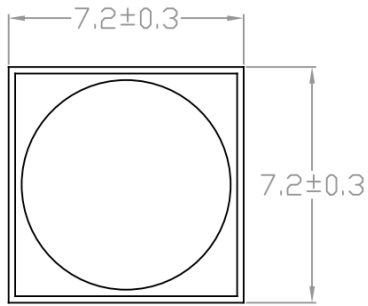

Recommended Solder Pad

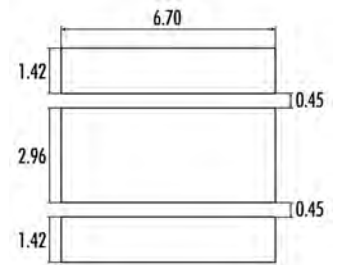

Note: The maximum offset (tolerance) for lens alignment over the LED is 0.2mm.

Soldering Guidelines

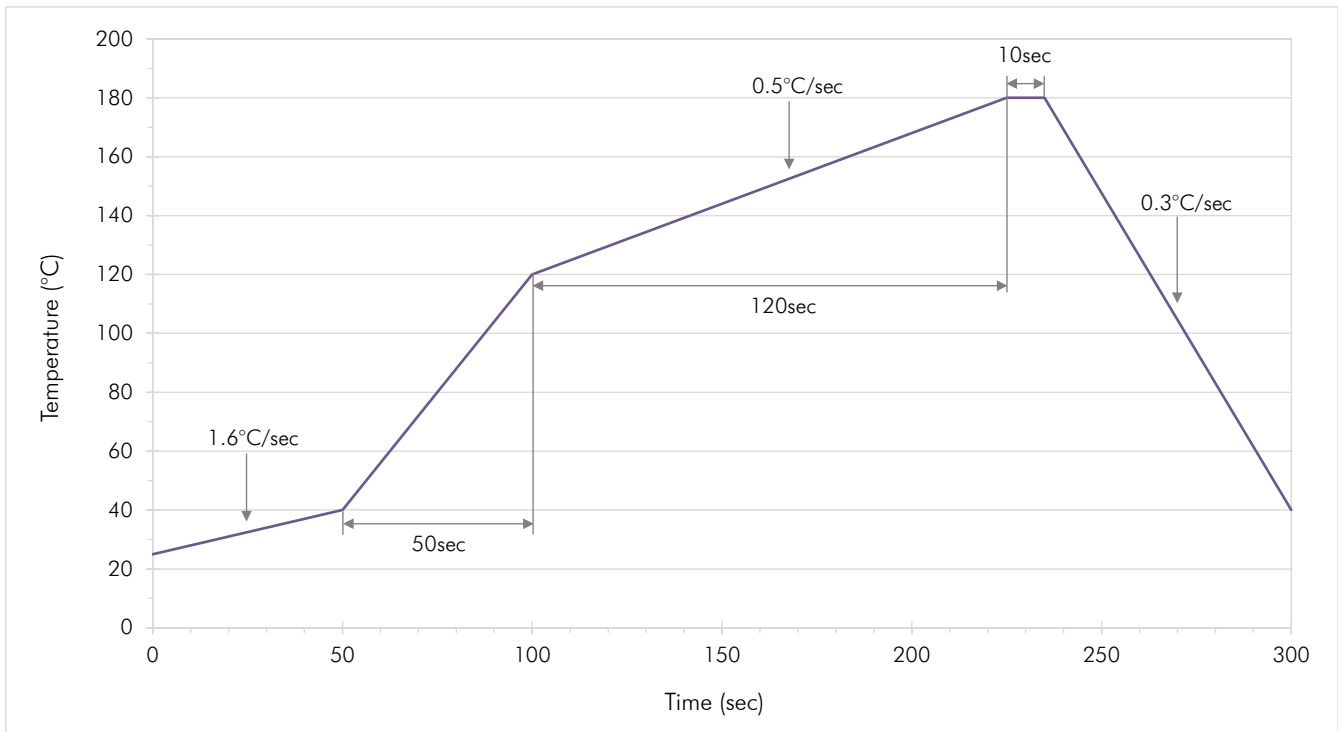

Reflow Profile Feature	Standard Parameters
Preheat Temperature Minimum	40°C
Preheat Temperature Maximum	120°C
Preheat Time	50 sec
Preheat Ramp-Up Rate	1.6°C/sec
Peak Temperature	±5°C
Time from Preheat Maximum Temperature to Peak Temperature	120 sec
Ramp-Up Rate from Maximum Temperature to Peak Temperature	0.5°C/sec
Time Within 5°C of Peak Temperature	5 sec
Maximum Time Maintained at Peak Temperature within Tolerance	10 sec
Ramp-Down Rate	3°C/sec

Handling & Usage Precautions

- Exhibit extreme care when handling LEDs. Do not touch the LED with bare hands as doing so may contaminate and affect the optical characteristics of the LED. When using tweezers, do not apply excessive force, especially to the glass lens. Do not drop the LED as doing so may cause product damage.
- Ensure that electrostatic discharge specifications are followed. Static electricity and surge voltages may cause product damage. Proper electrostatic discharge protection equipment, working machinery, and protected mounting equipment are recommended.
- Do not expose the LEDs to volatile organic compounds as well as hazardous, acidic, and corrosive substances during storage and operation to avoid product damage.
- Do not apply excess mechanical force and vibration while handling the product.
- Do not expose the product to sudden changes in temperature, high humidity levels, and condensation.
- Ensure that the PCB is suitable for the product and be wary of LED placement and possible PCB warpage.
- To avoid fault issues, do not couple any electrical wires to the metal substrate of the MCPCB or COB. If any electrical wires from the power source have contact with the MCPCB's metal base under power ON conditions, permanent damage may occur due to inner arcing within the LED structure.
- Avoid grounding of the LED copper substrate. Transient charges can propagate from the ground to the heatsink and finally to the copper substrate of the LED unit and damage the dielectric layer from ground charges. An insulator must be placed between the heatsink and the benchtop to avoid transient charge propagation from the ground.

Storage Precautions

- Perform soldering as soon as the moisture-proof packaging is opened.
- After the storage duration has exceeded the recommended time, products may need to be baked before soldering.
- Do not expose the product to sudden changes in temperature, high humidity levels, and condensation. It is recommended to store all products in a controlled environment under 30°C free of dust.
- Please consult the Violumas engineering team for further information on storage precautions.

Eye Safety Precautions

- Avoid exposure to UV light during LED operation. Do not look directly into the UV light during LED operation. Do not look directly into the UV light during optical measurements even through optical instruments. Protect the body, skin, and eyes with UV protective equipment.
- Attach warning labels on all products and systems that use UV LEDs.

Cleaning Precautions

- Do not use brushes or organic solvents for cleaning the LEDs.
- Perform electrical and optical measurements before and after cleaning to ensure optimal performance.

Static Electricity Precautions

- Ensure that equipment and machinery are properly grounded.
- Anti-electrostatic attire (wristbands, gloves, footwear, etc.) is recommended.
- Damage inspection is recommended while performing characteristics inspection of LEDs.

Disclaimers

Violumas is not responsible for any damages that result from inaccurate use of the recommended guidelines. The information compiled in this document is a result of careful review of reference materials and reliable sources. Violumas does not make any claims regarding warranty or guarantee. It is recommended that each customer consults the Violumas engineering team before engaging Violumas products in extreme applications where the failure of the LED and damage to human health may be possible. Each user assumes full responsibility for determining the suitability of the use of Violumas products in various applications. Disassembling Violumas products without consent is prohibited. No part of these documents may be reproduced in any form without prior written permission from Violumas. Please note that the data presented in this document is measured from the use of exclusive Violumas patented products - the 3-PAD LED Flip Chip and the Pillar MCPCB.

VC1X1C48L6-255-V1 | Mid Power 255nm COB

The VC1X1C48L6-255-V1 is a mid power chip-on-board (COB) UV LED with a peak wavelength of $255\pm 5\text{nm}$. The COB is structured with a patented 3-PAD Flip Chip LED mounted onto a copper-based Pillar MCPCB to boost output efficiency and reduce the thermal resistance. The VC1X1C48L6-255-V1 is ready for plug and play with no soldering required and is ideal for mid power UV applications.



**VC1X1C48L6-255-V1 is also available with 30°, 120°, and 135° lenses. Please contact Violumas for specifications regarding alternative LED beam angles.*

Features & Benefits

- Dimensions: 15mm x 15mm x 3.3mm
- Typical Peak Wavelength: 255nm
- Equipped with a 60° fused silica lens*
- Ready for plug and play (solder-free)
- Poke-in connectors for easy wiring
- TVS built in for ESD protection
- Integrated thermal technology in LED chip and MCPCB for lowest thermal resistance & reduced thermal decay

Electro-Optical Characteristics at $I_F = 500\text{mA}$ and $T_A = 25^\circ\text{C}$

Parameter	Symbol	Unit	Min	Typical	Max
Peak Wavelength	λ_p	nm	250	255	260
Forward Voltage	V_F	V	5.6	5.9	6.4
Radiant Flux	P_O	mW	35	51	75
Full Width of Half Magnitude	$\Delta\lambda$	nm	-	13	-
Radiant Angle	$2\Phi_{1/2}$	Degree	-	60	-
Thermal Resistance, Junction to COB Bottom Surface	$R_{th}(J-B)$	$^\circ\text{C}/\text{W}$	-	0.9	-

Peak Wavelength Tolerance: $\pm 3\text{nm}$; Forward Voltage Tolerance: 0.1V ; Radiant Flux Tolerance: $\pm 10\%$

Absolute Maximum Ratings

Parameter	Symbol	Unit	Value
Forward Current	I_F	mA	700
Reverse Voltage	V_R	V	5
Power	P_D	W	4.8
Junction Temperature	T_J	$^\circ\text{C}$	90
Operating Temperature	T_{OPR}	$^\circ\text{C}$	-30 ~ 85
Storage Temperature	T_{STG}	$^\circ\text{C}$	-40 ~ 100

Note: Operating the LED at or above the listed absolute maximum ratings may affect device reliability and result in permanent LED failure.

Spectral Output

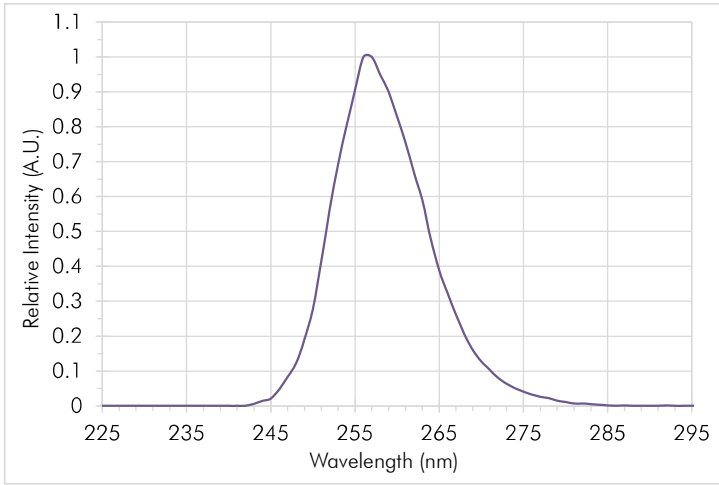

Radiation Pattern

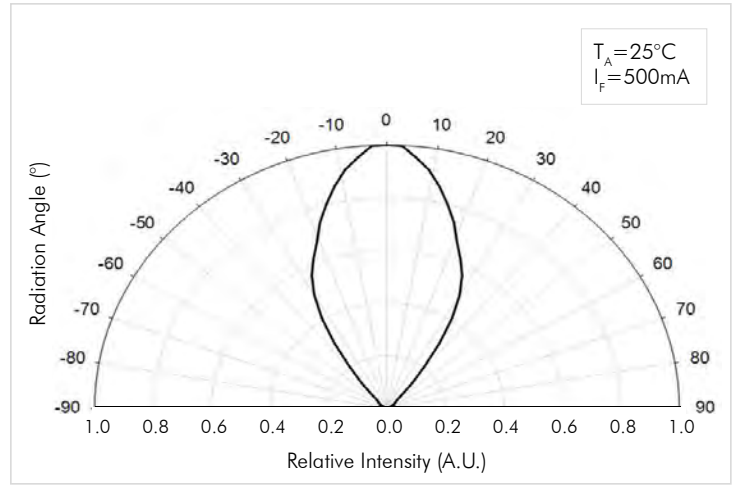

Forward Current vs. Relative Radiant Flux

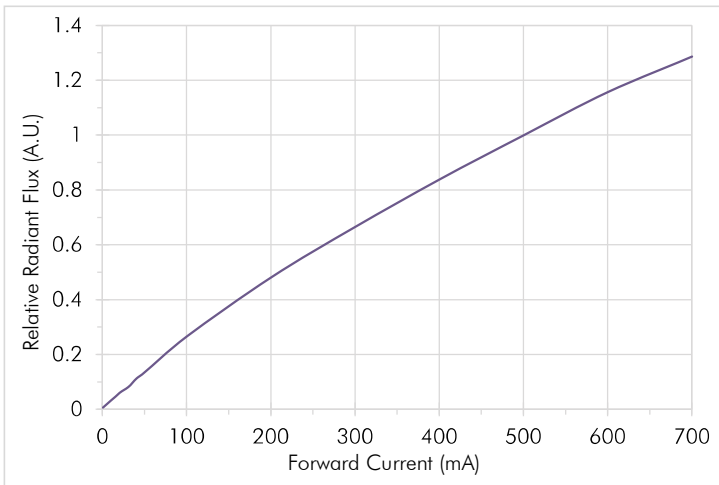

Forward Voltage vs. Forward Current

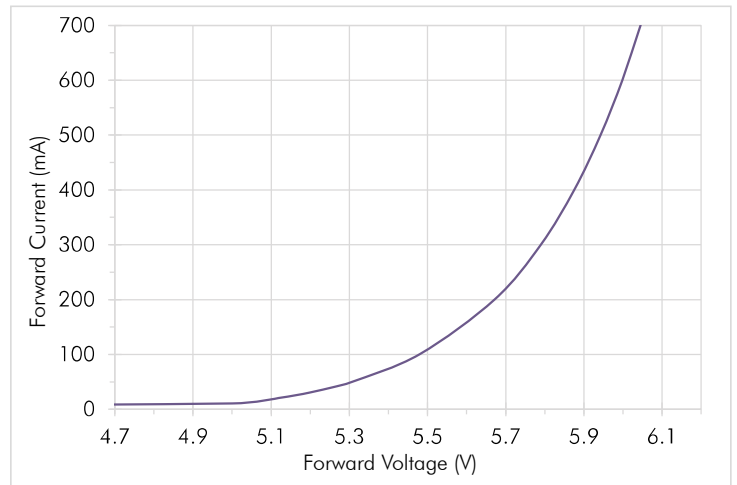

Mechanical Dimensions

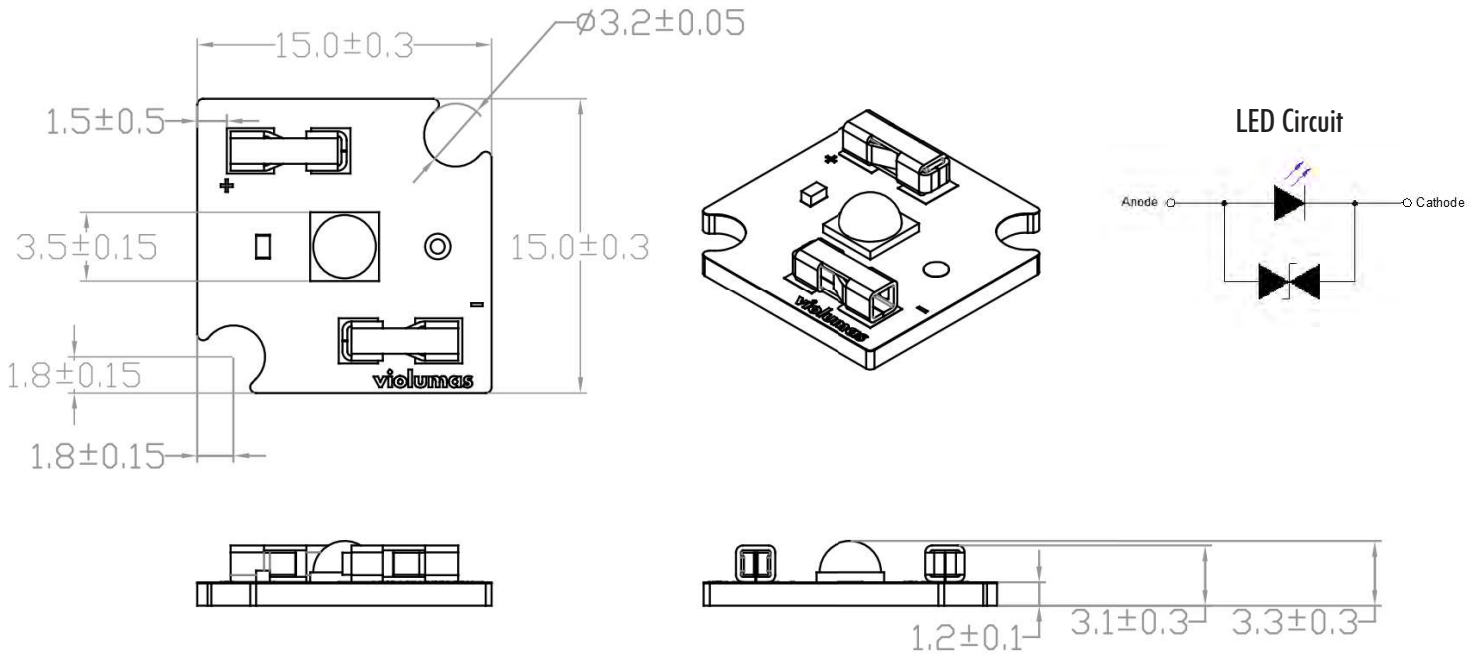

Note: The maximum offset (tolerance) for lens alignment over the LED is 0.2mm.

Product Overview

COB LEDs are ready for plug and play with no soldering required. All Violumas COBs are equipped with connectors for direct wiring and a TVS diode for protection against ESD and voltage issues.

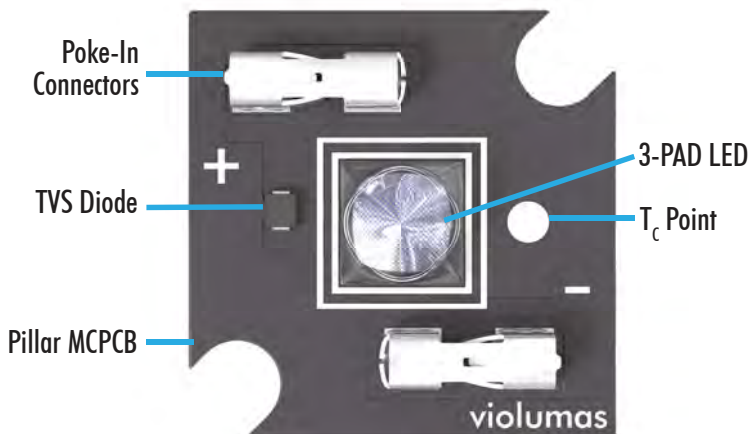

- Poke-in connectors for direct wiring (acceptable wire gauge: 20-24 AWG)
- Bi-directional TVS against 600W over-voltage surge



Note: Violumas COB products may be delivered with a protective tape on the backside of the LED. The tape should be removed before operation or assembly.

Handling & Usage Precautions

- Exhibit extreme care when handling LEDs. Do not touch the LED with bare hands as doing so may contaminate and affect the optical characteristics of the LED. When using tweezers, do not apply excessive force, especially to the glass lens. Do not drop the LED as doing so may cause product damage.
- Ensure that electrostatic discharge specifications are followed. Static electricity and surge voltages may cause product damage. Proper electrostatic discharge protection equipment, working machinery, and protected mounting equipment are recommended.
- Do not expose the LEDs to volatile organic compounds as well as hazardous, acidic, and corrosive substances during storage and operation to avoid product damage.
- Do not apply excess mechanical force and vibration while handling the product.
- Do not expose the product to sudden changes in temperature, high humidity levels, and condensation.
- To avoid fault issues, do not couple any electrical wires to the metal substrate of the MCPCB or COB. If any electrical wires from the power source have contact with the MCPCB's metal base under power ON conditions, permanent damage may occur due to inner arcing within the LED structure.
- Avoid grounding of the LED copper substrate. Transient charges can propagate from the ground to the heatsink and finally to the copper substrate of the LED unit and damage the dielectric layer from ground charges. An insulator must be placed between the heatsink and the benchtop to avoid transient charge propagation from the ground.

Storage Precautions

- Do not expose the product to sudden changes in temperature, high humidity levels, and condensation. It is recommended to store all products in a controlled environment under 30°C free of dust.
- Please consult the Violumas engineering team for further information on storage precautions.

Eye Safety Precautions

- Avoid exposure to UV light during LED operation. Do not look directly into the UV light during LED operation. Do not look directly into the UV light during optical measurements even through optical instruments. Protect the body, skin, and eyes with UV protective equipment.
- Attach warning labels on all products and systems that use UV LEDs.

Cleaning Precautions

- Do not use brushes or organic solvents for cleaning the LEDs.
- Perform electrical and optical measurements before and after cleaning to ensure optimal performance.

Static Electricity Precautions

- Ensure that equipment and machinery are properly grounded.
- Anti-electrostatic attire (wristbands, gloves, footwear, etc.) is recommended.
- Damage inspection is recommended while performing characteristics inspection of LEDs.

Disclaimers

Violumas is not responsible for any damages that result from inaccurate use of the recommended guidelines. The information compiled in this document is a result of careful review of reference materials and reliable sources. Violumas does not make any claims regarding warranty or guarantee. It is recommended that each customer consults the Violumas engineering team before engaging Violumas products in extreme applications where the failure of the LED and damage to human health may be possible. Each user assumes full responsibility for determining the suitability of the use of Violumas products in various applications. Disassembling Violumas products without consent is prohibited. No part of these documents may be reproduced in any form without prior written permission from Violumas. Please note that the data presented in this document is measured from the use of exclusive Violumas patented products - the 3-PAD LED Flip Chip and the Pillar MCPCB.

VC2X2C48L6-255-V1 | High Power 255nm COB

The VC2X2C48L6-255-V1 is a high power chip-on-board (COB) UV LED with a peak wavelength of $255\pm 5\text{nm}$. The COB is structured with four patented 3-PAD Flip Chip LEDs mounted onto a copper-based Pillar MCPCB to boost output efficiency and reduce the thermal resistance. The VC2X2C48L6-255-V1 is ready for plug and play with no soldering required and is ideal for high power UV applications.

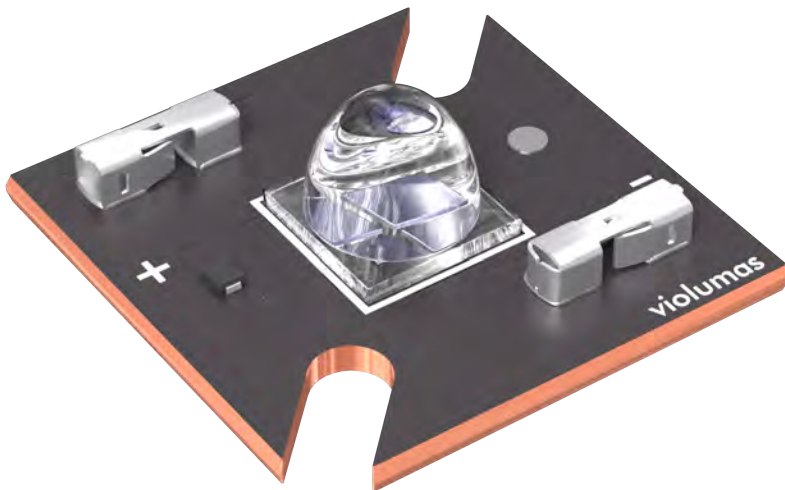

**VC2X2C48L6-255-V1 is also available with a 135° lens. Please contact Violumas for specifications regarding alternative LED beam angles.*

Features & Benefits

- Dimensions: 20mm x 20mm x 6.0mm
- Typical Peak Wavelength: 255nm
- Equipped with a 60° fused silica lens*
- Ready for plug and play (solder-free)
- Poke-in connectors for easy wiring
- TVS built in for ESD protection
- Integrated thermal technology in LED chips and MCPCB for lowest thermal resistance & reduced thermal decay

Electro-Optical Characteristics at $I_F = 1000\text{mA}$ and $T_A = 25^\circ\text{C}$

Parameter	Symbol	Unit	Min	Typical	Max
Peak Wavelength	λ_p	nm	250	255	260
Forward Voltage	V_F	V	11.2	11.8	12.8
Radiant Flux	P_O	mW	145	200	270
Full Width of Half Magnitude	$\Delta\lambda$	nm	-	13	-
Radiant Angle	$2\Phi_{1/2}$	Degree	-	60	-
Thermal Resistance, Junction to COB Bottom Surface	$R_{th}(J-B)$	$^\circ\text{C}/\text{W}$	-	0.32	-

Peak Wavelength Tolerance: $\pm 3\text{nm}$; Forward Voltage Tolerance: 0.1V ; Radiant Flux Tolerance: $\pm 10\%$

Absolute Maximum Ratings

Parameter	Symbol	Unit	Value
Forward Current	I_F	mA	1400
Reverse Voltage	V_R	V	10
Power	P_D	W	19
Junction Temperature	T_J	$^\circ\text{C}$	90
Operating Temperature	T_{OPR}	$^\circ\text{C}$	-30 ~ 85
Storage Temperature	T_{STG}	$^\circ\text{C}$	-40 ~ 100

Note: Operating the LED at or above the listed absolute maximum ratings may affect device reliability and result in permanent LED failure.

Spectral Output

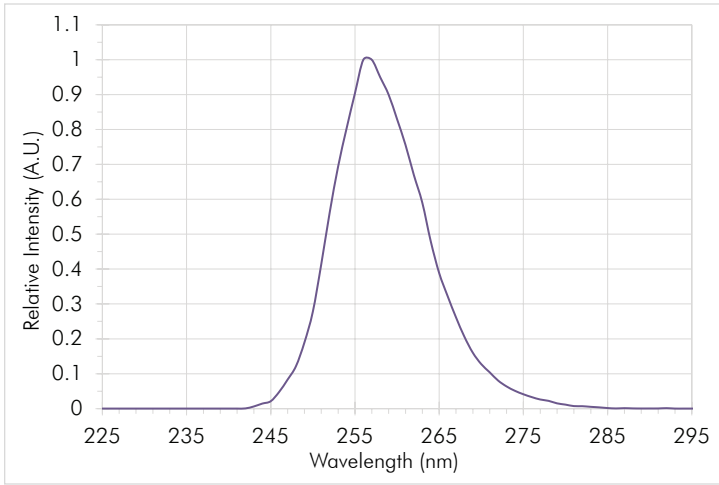

Radiation Pattern

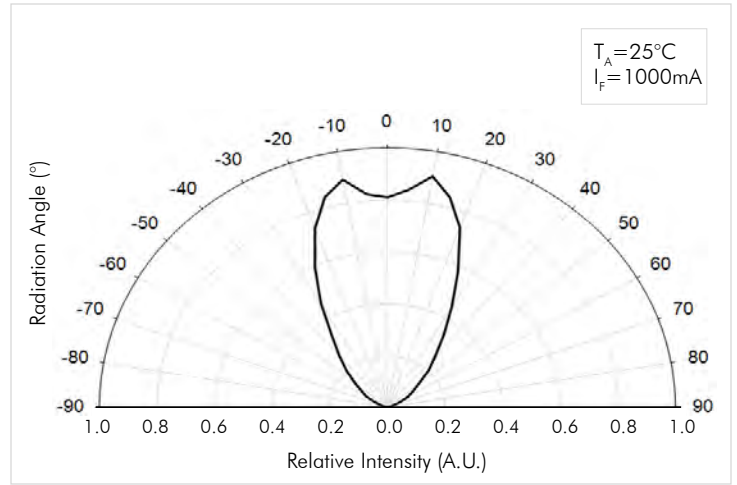

Forward Current vs. Relative Radiant Flux

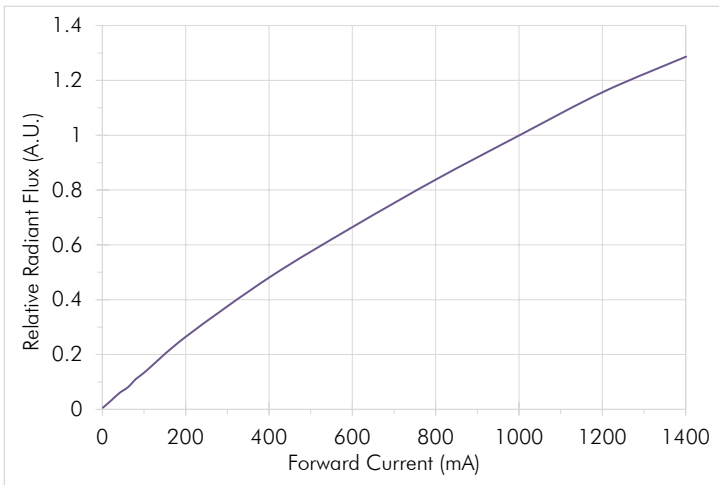

Forward Voltage vs. Forward Current

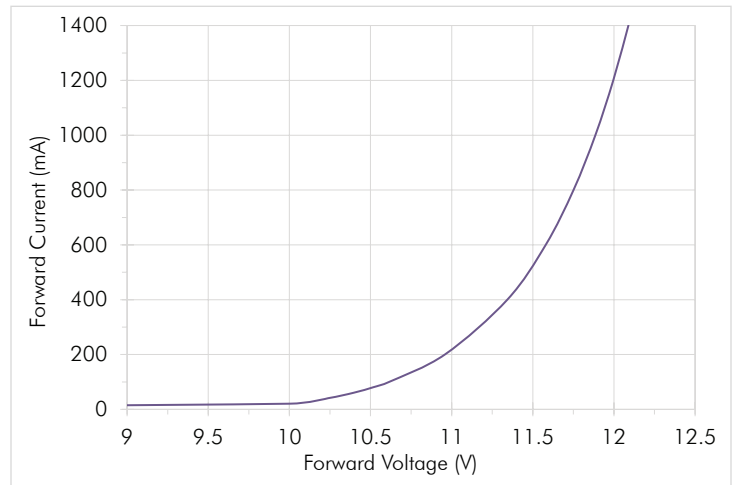

Mechanical Dimensions

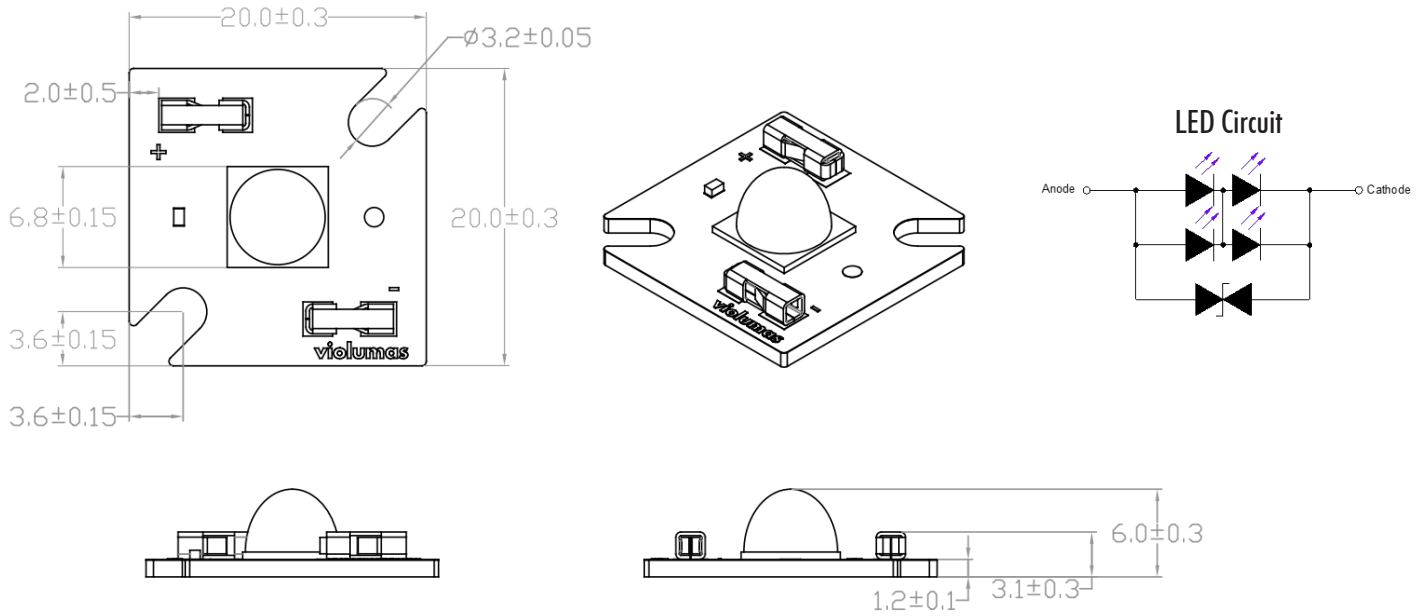

Note: The maximum offset (tolerance) for lens alignment over the LED is 0.2mm.

Product Overview

COB LEDs are ready for plug and play with no soldering required. All Violumas COBs are equipped with connectors for direct wiring and a TVS diode for protection against ESD and voltage issues.

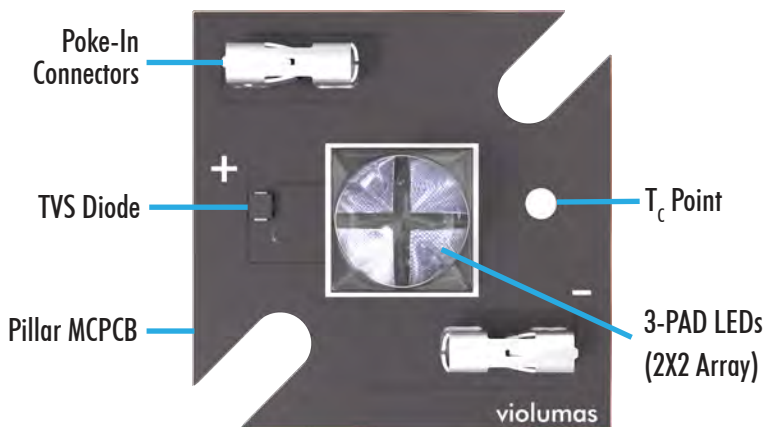

- Poke-in connectors for direct wiring (acceptable wire gauge: 20-24 AWG)
- Bi-directional TVS against 600W over-voltage surge

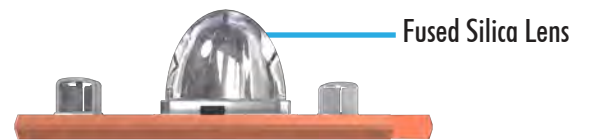

Note: Violumas COB products may be delivered with a protective tape on the backside of the LED. The tape should be removed before operation or assembly.

Handling & Usage Precautions

- Exhibit extreme care when handling LEDs. Do not touch the LED with bare hands as doing so may contaminate and affect the optical characteristics of the LED. When using tweezers, do not apply excessive force, especially to the glass lens. Do not drop the LED as doing so may cause product damage.
- Ensure that electrostatic discharge specifications are followed. Static electricity and surge voltages may cause product damage. Proper electrostatic discharge protection equipment, working machinery, and protected mounting equipment are recommended.
- Do not expose the LEDs to volatile organic compounds as well as hazardous, acidic, and corrosive substances during storage and operation to avoid product damage.
- Do not apply excess mechanical force and vibration while handling the product.
- Do not expose the product to sudden changes in temperature, high humidity levels, and condensation.
- To avoid fault issues, do not couple any electrical wires to the metal substrate of the MCPCB or COB. If any electrical wires from the power source have contact with the MCPCB's metal base under power ON conditions, permanent damage may occur due to inner arcing within the LED structure.
- Avoid grounding of the LED copper substrate. Transient charges can propagate from the ground to the heatsink and finally to the copper substrate of the LED unit and damage the dielectric layer from ground charges. An insulator must be placed between the heatsink and the benchtop to avoid transient charge propagation from the ground.

Storage Precautions

- Do not expose the product to sudden changes in temperature, high humidity levels, and condensation. It is recommended to store all products in a controlled environment under 30°C free of dust.
- Please consult the Violumas engineering team for further information on storage precautions.

Eye Safety Precautions

- Avoid exposure to UV light during LED operation. Do not look directly into the UV light during LED operation. Do not look directly into the UV light during optical measurements even through optical instruments. Protect the body, skin, and eyes with UV protective equipment.
- Attach warning labels on all products and systems that use UV LEDs.

Cleaning Precautions

- Do not use brushes or organic solvents for cleaning the LEDs.
- Perform electrical and optical measurements before and after cleaning to ensure optimal performance.

Static Electricity Precautions

- Ensure that equipment and machinery are properly grounded.
- Anti-electrostatic attire (wristbands, gloves, footwear, etc.) is recommended.
- Damage inspection is recommended while performing characteristics inspection of LEDs.

Disclaimers

Violumas is not responsible for any damages that result from inaccurate use of the recommended guidelines. The information compiled in this document is a result of careful review of reference materials and reliable sources. Violumas does not make any claims regarding warranty or guarantee. It is recommended that each customer consults the Violumas engineering team before engaging Violumas products in extreme applications where the failure of the LED and damage to human health may be possible. Each user assumes full responsibility for determining the suitability of the use of Violumas products in various applications. Disassembling Violumas products without consent is prohibited. No part of these documents may be reproduced in any form without prior written permission from Violumas. Please note that the data presented in this document is measured from the use of exclusive Violumas patented products - the 3-PAD LED Flip Chip and the Pillar MCPCB.

VC3X3C48L9-255-V1 | High Density 255nm COB

The VC3X3C48L9-255-V1 is a high density chip-on-board (COB) UV LED with a peak wavelength of $255\pm 5\text{nm}$. The COB is structured with nine patented 3-PAD Flip Chip LEDs mounted onto a copper-based Pillar MCPCB to boost output efficiency and reduce the thermal resistance. The VC3X3C48L9-255-V1 is ready for plug and play with no soldering required and is ideal for high intensity UV applications.

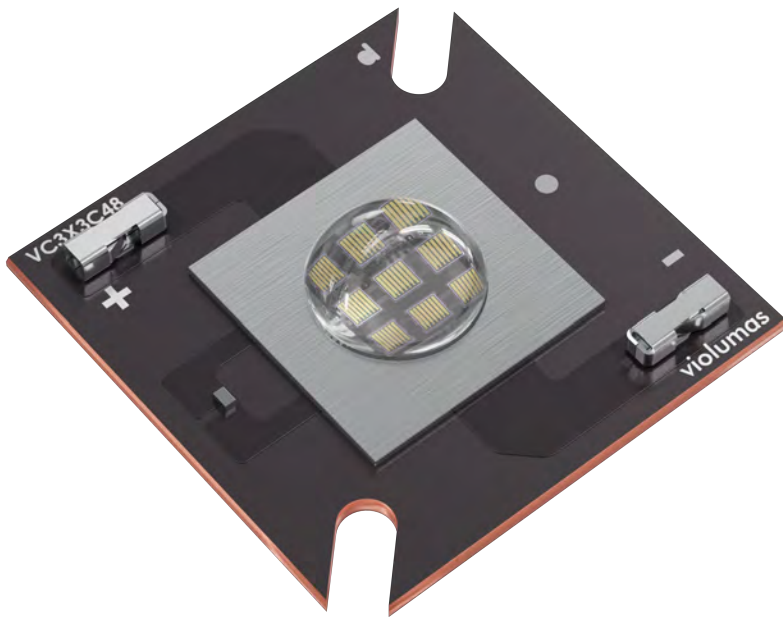

Features & Benefits

- Dimensions: 30mm x 30mm x 6.1mm
- Typical Peak Wavelength: 255nm
- Equipped with a 90° fused silica lens
- Ready for plug and play (solder-free)
- Poke-in connectors for easy wiring
- TVS built in for ESD protection
- Integrated thermal technology in LED chips and MCPCB for lowest thermal resistance & reduced thermal decay

Electro-Optical Characteristics at $I_F = 1500\text{mA}$ and $T_A = 25^\circ\text{C}$

Parameter	Symbol	Unit	Min	Typical	Max
Peak Wavelength	λ_p	nm	250	255	260
Forward Voltage	V_F	V	16.8	17.7	19.2
Radiant Flux	P_O	mW	300	400	550
Full Width of Half Magnitude	$\Delta\lambda$	nm	-	13	-
Radiant Angle	$2\Phi_{1/2}$	Degree	-	90	-
Thermal Resistance, Junction to COB Bottom Surface	$R_{th}(J-B)$	$^\circ\text{C}/\text{W}$	-	0.1	-

Peak Wavelength Tolerance: $\pm 3\text{nm}$; Forward Voltage Tolerance: 0.1V ; Radiant Flux Tolerance: $\pm 10\%$

Absolute Maximum Ratings

Parameter	Symbol	Unit	Value
Forward Current	I_F	mA	2100
Reverse Voltage	V_R	V	15
Power	P_D	W	43
Junction Temperature	T_J	$^\circ\text{C}$	90
Operating Temperature	T_{OPR}	$^\circ\text{C}$	-30 ~ 85
Storage Temperature	T_{STG}	$^\circ\text{C}$	-40 ~ 100

Note: Operating the LED at or above the listed absolute maximum ratings may affect device reliability and result in permanent LED failure.

Spectral Output

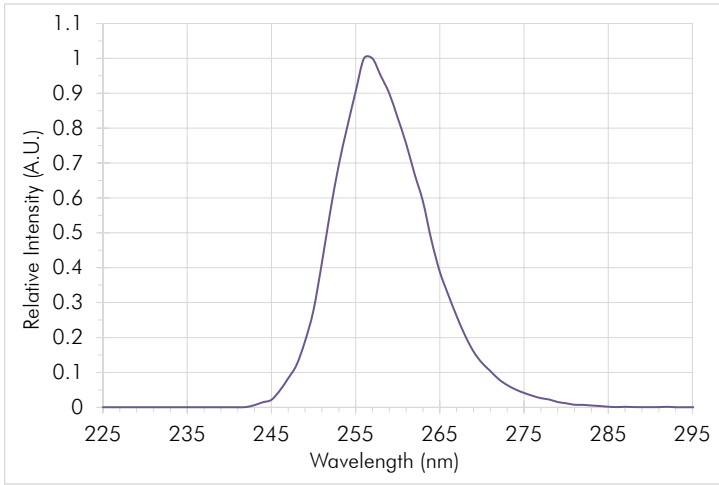

Radiation Pattern

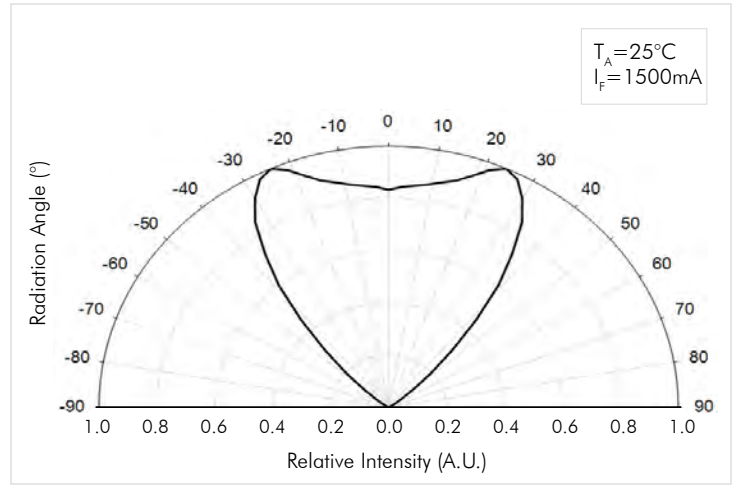

Forward Current vs. Relative Radiant Flux

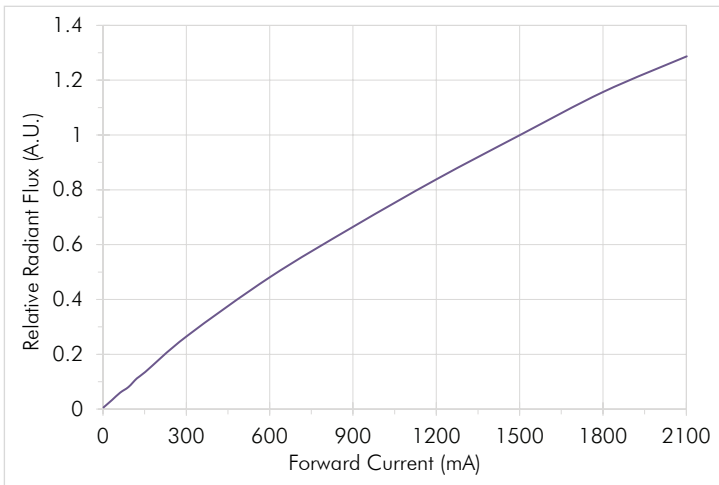

Forward Voltage vs. Forward Current

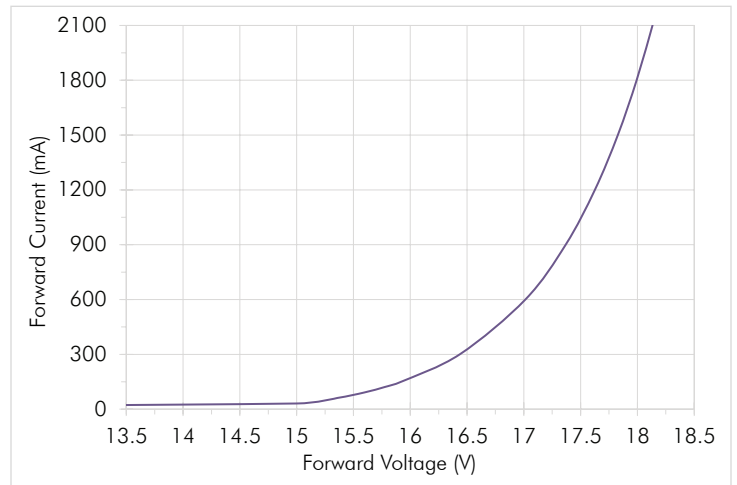

Mechanical Dimensions

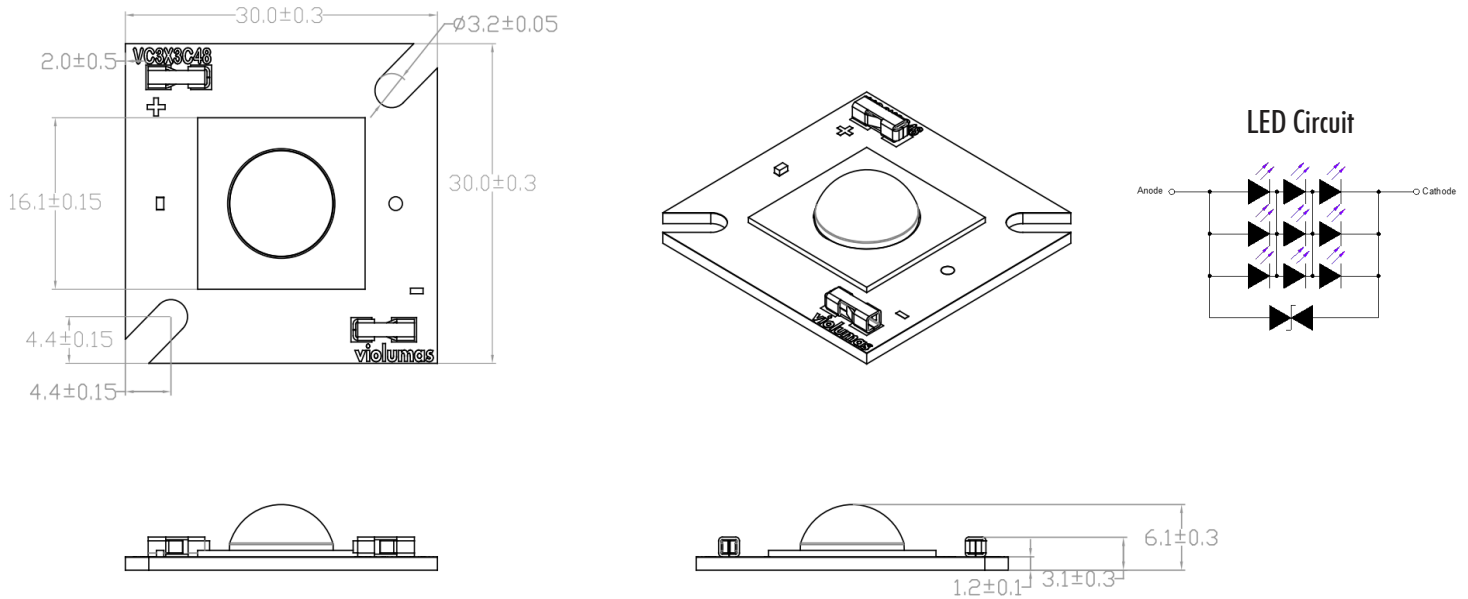

Note: The maximum offset (tolerance) for lens alignment over the LED is 0.2mm.

Product Overview

COB LEDs are ready for plug and play with no soldering required. All Violumas COBs are equipped with connectors for direct wiring and a TVS diode for protection against ESD and voltage issues.

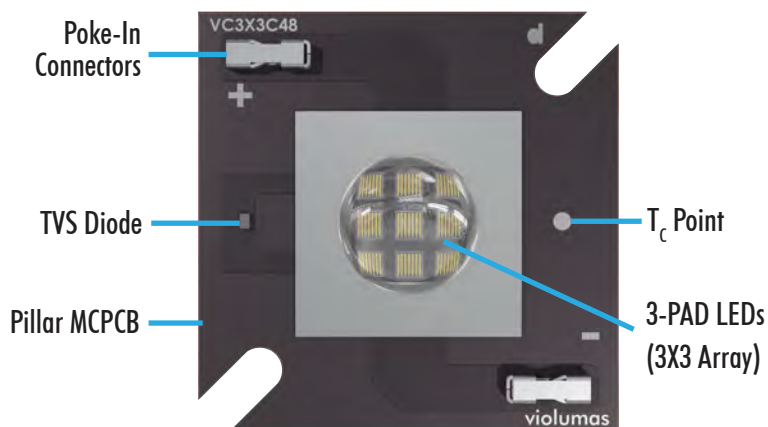

- Poke-in connectors for direct wiring (acceptable wire gauge: 20-24 AWG)
- Bi-directional TVS against 600W over-voltage surge

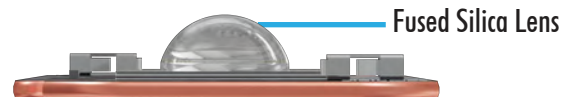

Note: Violumas COB products may be delivered with a protective tape on the backside of the LED. The tape should be removed before operation or assembly.

Handling & Usage Precautions

- Exhibit extreme care when handling LEDs. Do not touch the LED with bare hands as doing so may contaminate and affect the optical characteristics of the LED. When using tweezers, do not apply excessive force, especially to the glass lens. Do not drop the LED as doing so may cause product damage.
- Ensure that electrostatic discharge specifications are followed. Static electricity and surge voltages may cause product damage. Proper electrostatic discharge protection equipment, working machinery, and protected mounting equipment are recommended.
- Do not expose the LEDs to volatile organic compounds as well as hazardous, acidic, and corrosive substances during storage and operation to avoid product damage.
- Do not apply excess mechanical force and vibration while handling the product.
- Do not expose the product to sudden changes in temperature, high humidity levels, and condensation.
- To avoid fault issues, do not couple any electrical wires to the metal substrate of the MCPCB or COB. If any electrical wires from the power source have contact with the MCPCB's metal base under power ON conditions, permanent damage may occur due to inner arcing within the LED structure.
- Avoid grounding of the LED copper substrate. Transient charges can propagate from the ground to the heatsink and finally to the copper substrate of the LED unit and damage the dielectric layer from ground charges. An insulator must be placed between the heatsink and the benchtop to avoid transient charge propagation from the ground.

Storage Precautions

- Do not expose the product to sudden changes in temperature, high humidity levels, and condensation. It is recommended to store all products in a controlled environment under 30°C free of dust.
- Please consult the Violumas engineering team for further information on storage precautions.

Eye Safety Precautions

- Avoid exposure to UV light during LED operation. Do not look directly into the UV light during LED operation. Do not look directly into the UV light during optical measurements even through optical instruments. Protect the body, skin, and eyes with UV protective equipment.
- Attach warning labels on all products and systems that use UV LEDs.

Cleaning Precautions

- Do not use brushes or organic solvents for cleaning the LEDs.
- Perform electrical and optical measurements before and after cleaning to ensure optimal performance.

Static Electricity Precautions

- Ensure that equipment and machinery are properly grounded.
- Anti-electrostatic attire (wristbands, gloves, footwear, etc.) is recommended.
- Damage inspection is recommended while performing characteristics inspection of LEDs.

Disclaimers

Violumas is not responsible for any damages that result from inaccurate use of the recommended guidelines. The information compiled in this document is a result of careful review of reference materials and reliable sources. Violumas does not make any claims regarding warranty or guarantee. It is recommended that each customer consults the Violumas engineering team before engaging Violumas products in extreme applications where the failure of the LED and damage to human health may be possible. Each user assumes full responsibility for determining the suitability of the use of Violumas products in various applications. Disassembling Violumas products without consent is prohibited. No part of these documents may be reproduced in any form without prior written permission from Violumas. Please note that the data presented in this document is measured from the use of exclusive Violumas patented products - the 3-PAD LED Flip Chip and the Pillar MCPCB.

VC4X4C48L9-255-V1 | High Density 255nm COB

The VC4X4C48L9-255-V1 is a high density chip-on-board (COB) UV LED with a peak wavelength of $255\pm 5\text{nm}$. The COB is structured with sixteen patented 3-PAD Flip Chip LEDs mounted onto a copper-based Pillar MCPCB to boost output efficiency and reduce the thermal resistance. The VC4X4C48L9-255-V1 is ready for plug and play with no soldering required and is ideal for high intensity UV applications.

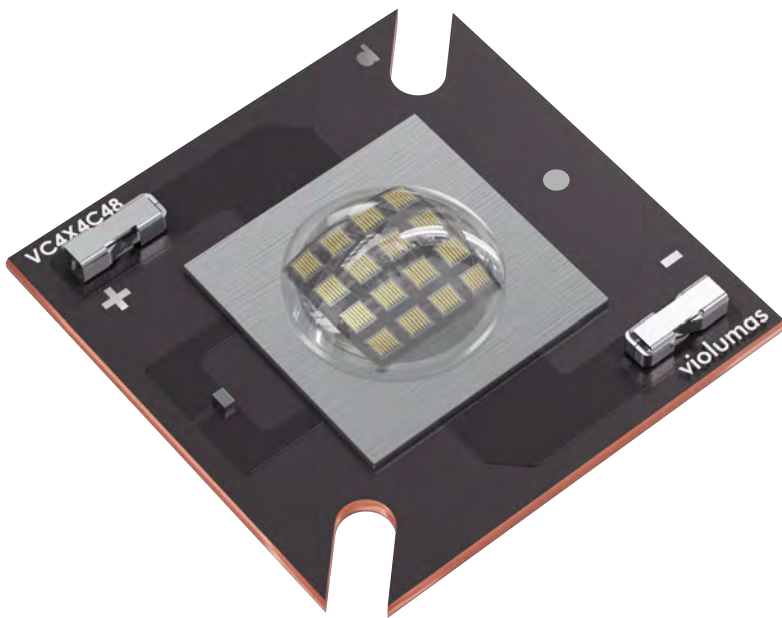

Features & Benefits

- Dimensions: 30mm x 30mm x 5.4mm
- Typical Peak Wavelength: 255nm
- Equipped with a 90° fused silica lens
- Ready for plug and play (solder-free)
- Poke-in connectors for easy wiring
- TVS built in for ESD protection
- Integrated thermal technology in LED chips and MCPCB for lowest thermal resistance & reduced thermal decay

Electro-Optical Characteristics at $I_F = 2000\text{mA}$ and $T_A = 25^\circ\text{C}$

Parameter	Symbol	Unit	Min	Typical	Max
Peak Wavelength	λ_p	nm	250	255	260
Forward Voltage	V_F	V	22.4	23.6	25.6
Radiant Flux	P_O	mW	490	660	890
Full Width of Half Magnitude	$\Delta\lambda$	nm	-	13	-
Radiant Angle	$2\Phi_{1/2}$	Degree	-	90	-
Thermal Resistance, Junction to COB Bottom Surface	$R_{th}(J-B)$	$^\circ\text{C}/\text{W}$	-	0.06	-

Peak Wavelength Tolerance: $\pm 3\text{nm}$; Forward Voltage Tolerance: 0.1V ; Radiant Flux Tolerance: $\pm 10\%$

Absolute Maximum Ratings

Parameter	Symbol	Unit	Value
Forward Current	I_F	mA	2800
Reverse Voltage	V_R	V	20
Power	P_D	W	77
Junction Temperature	T_J	$^\circ\text{C}$	90
Operating Temperature	T_{OPR}	$^\circ\text{C}$	-30 ~ 85
Storage Temperature	T_{STG}	$^\circ\text{C}$	-40 ~ 100

Note: Operating the LED at or above the listed absolute maximum ratings may affect device reliability and result in permanent LED failure.

Spectral Output

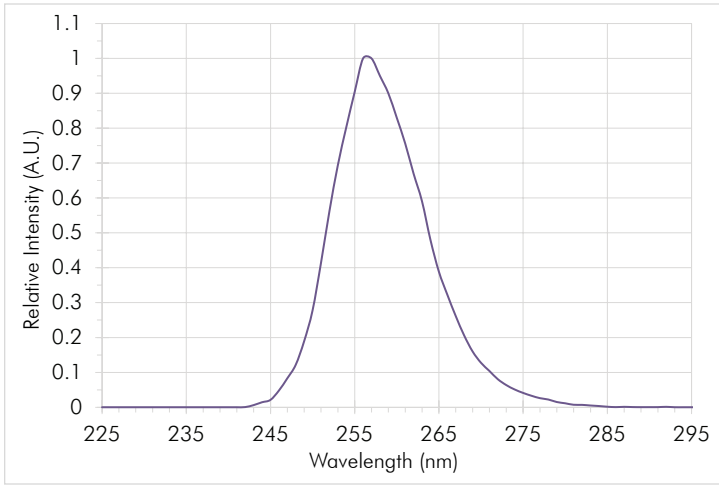

Radiation Pattern

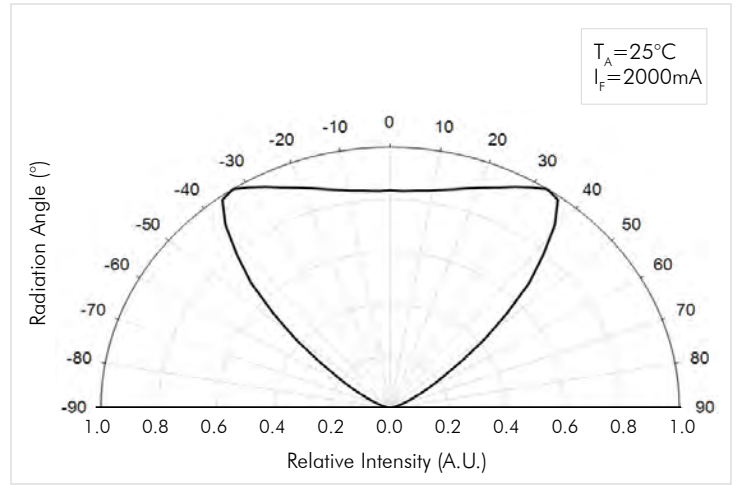

Forward Current vs. Relative Radiant Flux

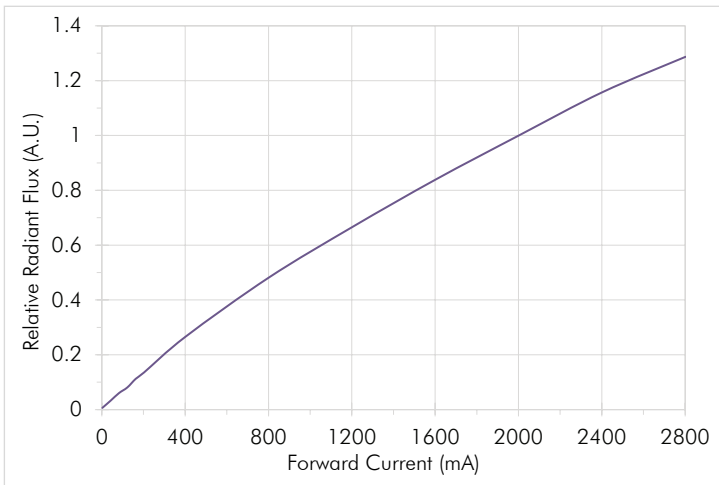

Forward Voltage vs. Forward Current

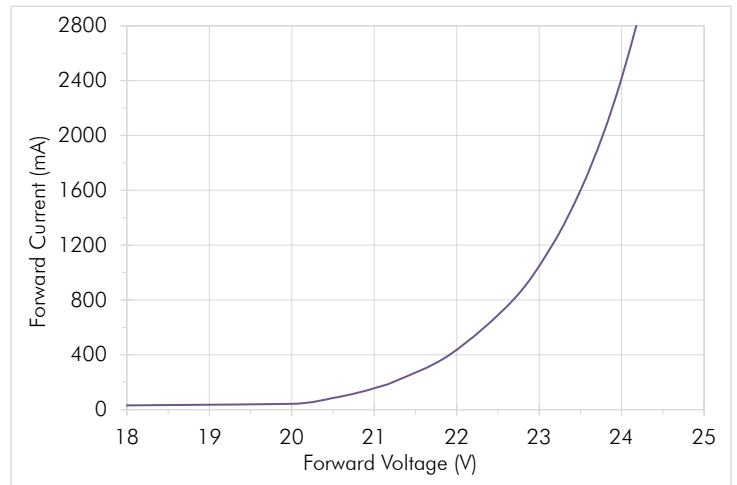

Mechanical Dimensions

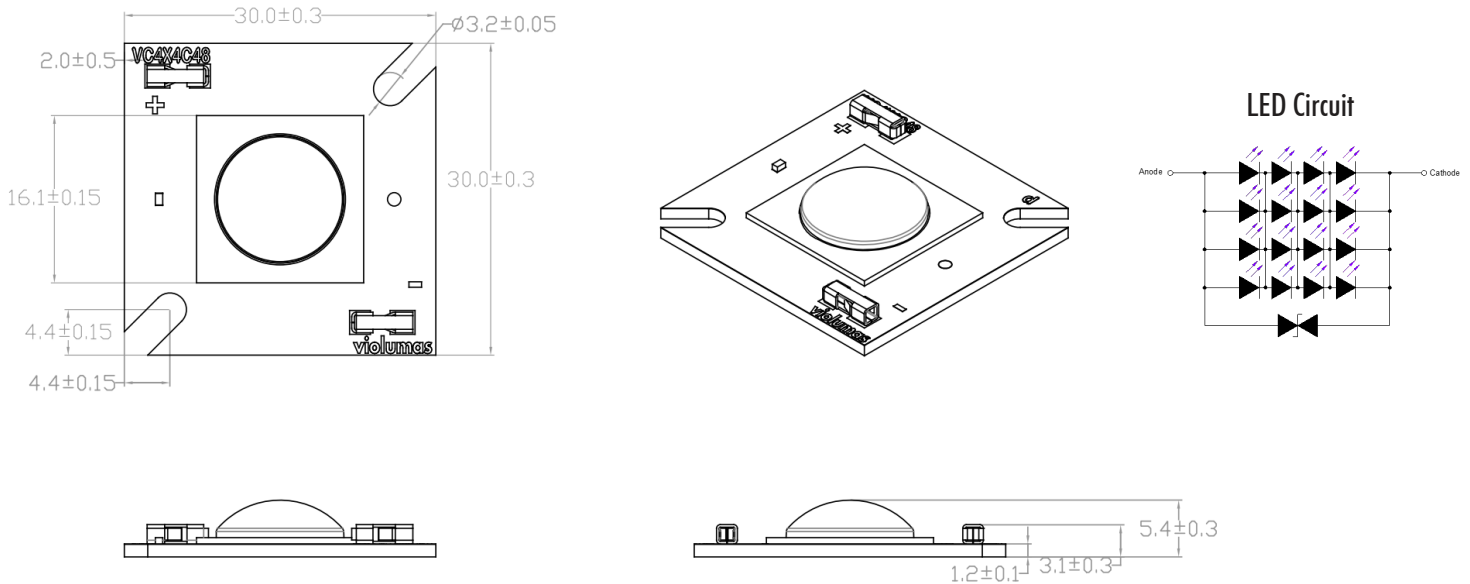

Note: The maximum offset (tolerance) for lens alignment over the LED is 0.2mm.

Product Overview

COB LEDs are ready for plug and play with no soldering required. All Violumas COBs are equipped with connectors for direct wiring and a TVS diode for protection against ESD and voltage issues.

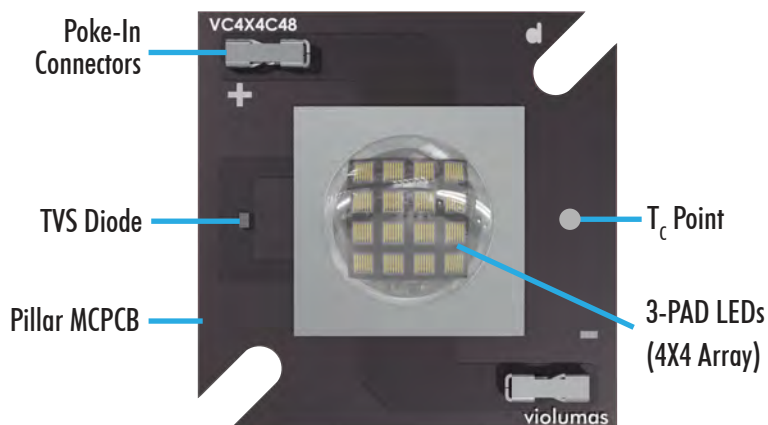

- Poke-in connectors for direct wiring (acceptable wire gauge: 20-24 AWG)
- Bi-directional TVS against 600W over-voltage surge

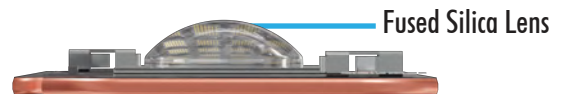

Note: Violumas COB products may be delivered with a protective tape on the backside of the LED. The tape should be removed before operation or assembly.

Handling & Usage Precautions

- Exhibit extreme care when handling LEDs. Do not touch the LED with bare hands as doing so may contaminate and affect the optical characteristics of the LED. When using tweezers, do not apply excessive force, especially to the glass lens. Do not drop the LED as doing so may cause product damage.
- Ensure that electrostatic discharge specifications are followed. Static electricity and surge voltages may cause product damage. Proper electrostatic discharge protection equipment, working machinery, and protected mounting equipment are recommended.
- Do not expose the LEDs to volatile organic compounds as well as hazardous, acidic, and corrosive substances during storage and operation to avoid product damage.
- Do not apply excess mechanical force and vibration while handling the product.
- Do not expose the product to sudden changes in temperature, high humidity levels, and condensation.
- To avoid fault issues, do not couple any electrical wires to the metal substrate of the MCPCB or COB. If any electrical wires from the power source have contact with the MCPCB's metal base under power ON conditions, permanent damage may occur due to inner arcing within the LED structure.
- Avoid grounding of the LED copper substrate. Transient charges can propagate from the ground to the heatsink and finally to the copper substrate of the LED unit and damage the dielectric layer from ground charges. An insulator must be placed between the heatsink and the benchtop to avoid transient charge propagation from the ground.

Storage Precautions

- Do not expose the product to sudden changes in temperature, high humidity levels, and condensation. It is recommended to store all products in a controlled environment under 30°C free of dust.
- Please consult the Violumas engineering team for further information on storage precautions.

Eye Safety Precautions

- Avoid exposure to UV light during LED operation. Do not look directly into the UV light during LED operation. Do not look directly into the UV light during optical measurements even through optical instruments. Protect the body, skin, and eyes with UV protective equipment.
- Attach warning labels on all products and systems that use UV LEDs.

Cleaning Precautions

- Do not use brushes or organic solvents for cleaning the LEDs.
- Perform electrical and optical measurements before and after cleaning to ensure optimal performance.

Static Electricity Precautions

- Ensure that equipment and machinery are properly grounded.
- Anti-electrostatic attire (wristbands, gloves, footwear, etc.) is recommended.
- Damage inspection is recommended while performing characteristics inspection of LEDs.

Disclaimers

Violumas is not responsible for any damages that result from inaccurate use of the recommended guidelines. The information compiled in this document is a result of careful review of reference materials and reliable sources. Violumas does not make any claims regarding warranty or guarantee. It is recommended that each customer consults the Violumas engineering team before engaging Violumas products in extreme applications where the failure of the LED and damage to human health may be possible. Each user assumes full responsibility for determining the suitability of the use of Violumas products in various applications. Disassembling Violumas products without consent is prohibited. No part of these documents may be reproduced in any form without prior written permission from Violumas. Please note that the data presented in this document is measured from the use of exclusive Violumas patented products - the 3-PAD LED Flip Chip and the Pillar MCPCB.

VC12X1 Series | 12-LED Light Bar COB

The VC12X1 Series is a 12-LED light bar chip-on-board (COB) UV LED available in 405nm, 395nm, 385nm, 375nm, 365nm, 310nm, 295nm, 275nm, 265nm, and 255nm wavelengths. The COB is structured with twelve patented 3-PAD Flip Chip LEDs mounted onto a copper-based Pillar MCPCB to boost output efficiency and reduce the thermal resistance. The VC12X1 Series is ready for plug and play with no soldering required and is ideal for large-area UV applications.



Features & Benefits

- Dimensions: 304mm x 20mm
- Available in UVA, UVB, and UVC
- Equipped with 60° fused silica lenses*
- Ready for plug and play (solder-free)
- Poke-in connectors for easy wiring
- TVS built in for ESD protection
- Integrated thermal technology in LED chips and MCPCB for lowest thermal resistance & reduced thermal decay

**VC12X1 Series is also available with alternative lens types. Please contact Violumas for specifications regarding alternative LED beam angles.*

Electro-Optical Characteristics for 405nm, 395nm, 385nm, 375nm, 365nm ($I_F=700\text{mA}$ and $T_A=25^\circ\text{C}$)

Part Number	Wavelength	Radiant Flux	Forward Voltage	Power
VC12X1C45L6-405	405nm	12W	44.4V	31.1W
VC12X1C45L6-395	395nm	13W	44.8V	31.3W
VC12X1C45L6-385	385nm	12W	46.8V	32.8W
VC12X1C45L6-375	375nm	9W	46.8V	32.8W
VC12X1C45L6-365	365nm	6W	49.2V	34.4W

Peak Wavelength Tolerance: $\pm 3\text{nm}$; Forward Voltage Tolerance: 0.1V ; Radiant Flux Tolerance: $\pm 10\%$

Absolute Maximum Ratings for 405nm, 395nm, 385nm, 375nm, 365nm

Parameter	Symbol	Unit	Value
Forward Current	I_F	mA	1000
Reverse Voltage	V_R	V	60
Power	P_O	W	48
Junction Temperature	T_J	$^\circ\text{C}$	90
Operating Temperature	T_{OPR}	$^\circ\text{C}$	-30 ~ 85
Storage Temperature	T_{STG}	$^\circ\text{C}$	-40 ~ 100

Note: Operating the LED at or above the listed absolute maximum ratings may affect device reliability and result in permanent LED failure.

Please contact Violumas for additional information regarding performance curves, irradiance maps, and suitable heatsinks/drivers for this product.

Electro-Optical Characteristics for 310nm, 295nm, 275nm, 265nm ($I_F = 1400\text{mA}$ and $T_A = 25^\circ\text{C}$)

Part Number	Wavelength	Radiant Flux	Forward Voltage	Power
VC12X1C48L6-310-V1	308nm	1.44W	36.0V	50.4W
VC12X1C48L6-295	295nm	1.1W	34.8V	48.7W
VC12X1C48L6-275-V1	275nm	1.56W	37.2V	52.1W
VC12X1C48L6-265-V1	265nm	1.32W	37.2V	52.1W

Peak Wavelength Tolerance: $\pm 3\text{nm}$; Forward Voltage Tolerance: 0.1V; Radiant Flux Tolerance: $\pm 10\%$

Electro-Optical Characteristics for 255nm ($I_F = 1000\text{mA}$ and $T_A = 25^\circ\text{C}$)

Part Number	Wavelength	Radiant Flux	Forward Voltage	Power
VC12X1C48L6-255-V1	255nm	0.61W	35.4V	35.4W

Peak Wavelength Tolerance: $\pm 3\text{nm}$; Forward Voltage Tolerance: 0.1V; Radiant Flux Tolerance: $\pm 10\%$

Absolute Maximum Ratings for 310nm, 295nm, 275nm, 265nm, 255nm

Parameter	Symbol	Unit	Value	Value
			310nm, 295nm, 275nm, 265nm	255nm
Forward Current	I_F	mA	2000	1400
Reverse Voltage	V_R	V	30	30
Power	P_O	W	78	57
Junction Temperature	T_J	$^\circ\text{C}$	90	90
Operating Temperature	T_{OPR}	$^\circ\text{C}$	-30 ~ 85	-30 ~ 85
Storage Temperature	T_{STG}	$^\circ\text{C}$	-40 ~ 100	-40 ~ 100

Note: Operating the LED at or above the listed absolute maximum ratings may affect device reliability and result in permanent LED failure.

Please contact Violumas for additional information regarding performance curves, irradiance maps, and suitable heatsinks/drivers for this product.

Mechanical Dimensions for 405nm, 395nm, 385nm, 375nm, 365nm

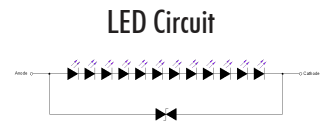
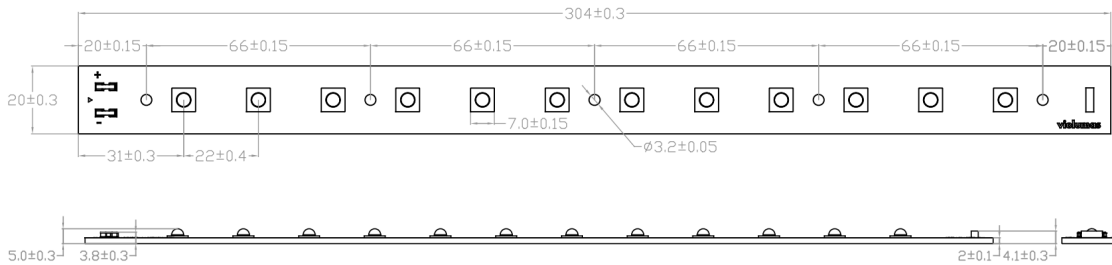

Mechanical Dimensions for 310nm, 295nm, 275nm, 265nm, 255nm

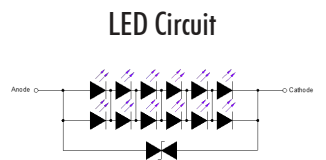
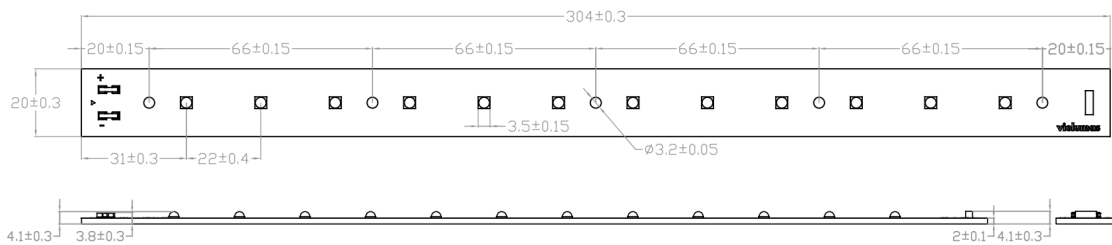

Note: The maximum offset (tolerance) for lens alignment over the LED is 0.2mm.

Product Overview

COB LEDs are ready for plug and play with no soldering required. All Violumas COBs are equipped with connectors for direct wiring and a TVS diode for protection against ESD and voltage issues.

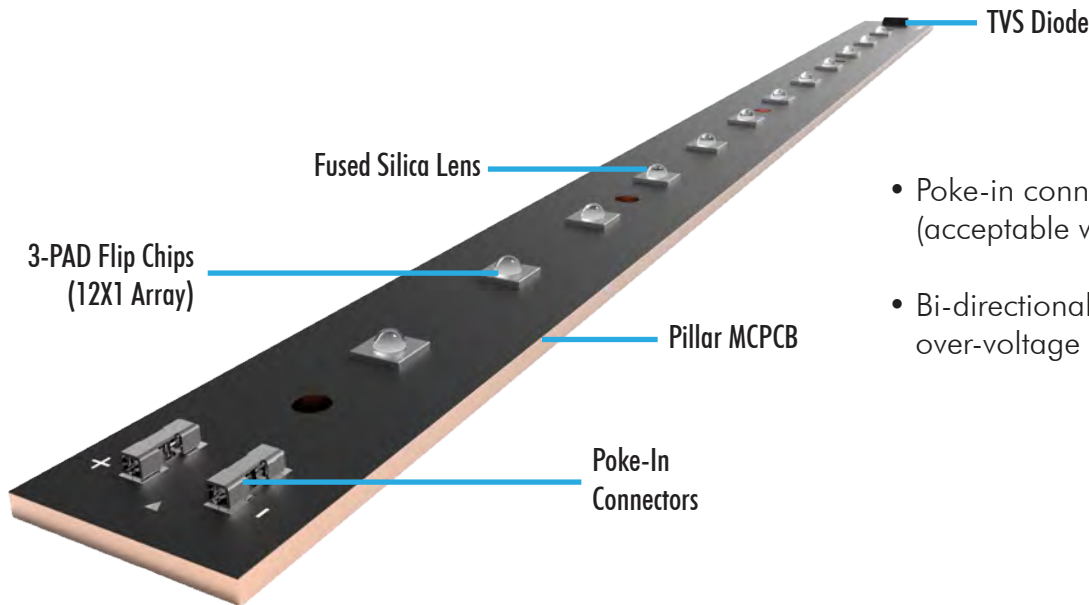

- Poke-in connectors for direct wiring (acceptable wire gauge: 20-24 AWG)
- Bi-directional TVS against 600W over-voltage surge

Note: Violumas COB products may be delivered with a protective tape on the backside of the LED. The tape should be removed before operation or assembly.

Handling & Usage Precautions

- Exhibit extreme care when handling LEDs. Do not touch the LED with bare hands as doing so may contaminate and affect the optical characteristics of the LED. When using tweezers, do not apply excessive force, especially to the glass lens. Do not drop the LED as doing so may cause product damage.
- Ensure that electrostatic discharge specifications are followed. Static electricity and surge voltages may cause product damage. Proper electrostatic discharge protection equipment, working machinery, and protected mounting equipment are recommended.
- Do not expose the LEDs to volatile organic compounds as well as hazardous, acidic, and corrosive substances during storage and operation to avoid product damage.
- Do not apply excess mechanical force and vibration while handling the product.
- Do not expose the product to sudden changes in temperature, high humidity levels, and condensation.
- To avoid fault issues, do not couple any electrical wires to the metal substrate of the MCPCB or COB. If any electrical wires from the power source have contact with the MCPCB's metal base under power ON conditions, permanent damage may occur due to inner arcing within the LED structure.
- Avoid grounding of the LED copper substrate. Transient charges can propagate from the ground to the heatsink and finally to the copper substrate of the LED unit and damage the dielectric layer from ground charges. An insulator must be placed between the heatsink and the benchtop to avoid transient charge propagation from the ground.

Storage Precautions

- Do not expose the product to sudden changes in temperature, high humidity levels, and condensation. It is recommended to store all products in a controlled environment under 30°C free of dust.
- Please consult the Violumas engineering team for further information on storage precautions.

Eye Safety Precautions

- Avoid exposure to UV light during LED operation. Do not look directly into the UV light during LED operation. Do not look directly into the UV light during optical measurements even through optical instruments. Protect the body, skin, and eyes with UV protective equipment.
- Attach warning labels on all products and systems that use UV LEDs.

Cleaning Precautions

- Do not use brushes or organic solvents for cleaning the LEDs.
- Perform electrical and optical measurements before and after cleaning to ensure optimal performance.

Static Electricity Precautions

- Ensure that equipment and machinery are properly grounded.
- Anti-electrostatic attire (wristbands, gloves, footwear, etc.) is recommended.
- Damage inspection is recommended while performing characteristics inspection of LEDs.

Disclaimers

Violumas is not responsible for any damages that result from inaccurate use of the recommended guidelines. The information compiled in this document is a result of careful review of reference materials and reliable sources. Violumas does not make any claims regarding warranty or guarantee. It is recommended that each customer consults the Violumas engineering team before engaging Violumas products in extreme applications where the failure of the LED and damage to human health may be possible. Each user assumes full responsibility for determining the suitability of the use of Violumas products in various applications. Disassembling Violumas products without consent is prohibited. No part of these documents may be reproduced in any form without prior written permission from Violumas. Please note that the data presented in this document is measured from the use of exclusive Violumas patented products - the 3-PAD LED Flip Chip and the Pillar MCPCB.