

SiC UV Photodiodes



- **Robust SiC photodiodes in hermetic TO-style packages**
- **UV lamp monitoring**



 **Boston**Electronics

91 Boylston Street, Brookline, MA 02445
tel: (617)566-3821 fax: (617)731-0935
www.boselec.com boselec@boselec.com

SIC UV PHOTODIODES



Content

- General information about the sglux SiC UV photodiodes **p. 1**
- An overview at the portfolio that ranges from 0.06 mm² until 36.00 mm² active area photodiodes with different housings, simple optics filtered for UVA, UVB, UVC or UV-Index spectral response **p. 2**
- Tutorial to answer beginners and users questions about best use of SiC UV photodiodes **p. 3**
- List of publications **p. 17**

GENERAL INFORMATION

about the sglux SiC UV photodiodes

About the material SiC

Applications that require UV photodiodes differ widely in required detector properties as well as in spectral and absolute sensitivity. In the field of flame detection very low radiation intensity must be reliably detected. The monitoring of UV purification lamps needs UV photodiodes that will operate in high UV brightness without degradation for many years. Monitoring of very powerful UV radiation emitted by UV curing lamps or LED arrays requires UV photodiodes that endure extreme UV radiation intensity. Monitoring the sun's UV, in particular the erythemal part of the sunlight requires photodiodes with perfect visible blindness and carefully tailored spectral response in the UV region.

Customers that apply Silicon Carbide UV photodiodes to these applications make the best choice within all these application variables. They profit from the very low dark current, near perfect visible blindness, bullet proof radiation hardness and low temperature coefficient of the signal, 0.1%/K. Operating temperature range is up to 170°C.

Our own SiC wafer production since 2009

Since 2009 sglux has produced its own SiC photodiodes, multielement linear SiC spectrometer arrays and SiC-quadrant chips. The sglux R&D team has almost 20 years of experience in producing UV sensitive semiconductor chips. This skill powered the SiC R&D work focusing on extreme radiation hardness. The German PTB in 2011 measured that the radiation hardness of the sglux SiC UV chips has improved by factor of two compared to 1st generation SiC, sensing chips produced by Cree, Inc. until 2007. Furthermore the visible blindness of the sglux chips was improved by five orders of magnitude compared with Cree SiC chips and now totals more than ten orders of magnitude of visible blindness. Please also refer to our list of publications (p. 17) of this catalog.

Photodiode amplification

In order to benefit from the superior properties of SiC UV photodiodes, carefully designed and produced amplifiers made of superior components are needed. Page 15 informs users about how to assemble and adjust such amplifiers. We support developers with a broad selection of ready-to-use amplifier modules. The sglux TOCON series are hybrid photodetectors in a TO5 housing that include such an amplifier stage and output a voltage of 0 to 5V. Please find more information about the TOCONs and the amplifiers at the sglux web-page.

SiC UV Photodiodes

Catalog

OVERVIEW AT THE PORTFOLIO

that ranges from 0.06 mm² until 36.00 mm² active area photodiodes with different housings, simple optics filtered for UVA, UVB, UVC or UV-Index spectral response

Nomenclature

The UV photodiodes follow the below nomenclature. All part numbers start with SG01 indicating a sglux SiC UV photodiode. The following table shows the selection opportunities:

SG01			
Chip area	Spectral response	Housing	Special
S, M, D, L, F, XL	nothing, A, B, C or E	18, 18ISO90, 18S, 5, 18ISO90S, 5ISO90	nothing, Lens, MEGA, GIGA, DIFFUSOR
S 0.06 mm ²	nothing = broad band UV $\lambda_{\max} = 280 \text{ nm}$ $\lambda_{510\%} = 221 \text{ nm} \dots 358 \text{ nm}$	18 2-pin TO18 housing, h = 5.2 mm, 1 pin isolated, 1 pin grounded	Lens with concentrating lens, TO5 only
M 0.20 mm ²	A = UVA $\lambda_{\max} = 331 \text{ nm}$ $\lambda_{510\%} = 309 \text{ nm} \dots 367 \text{ nm}$	18ISO90 3-pin TO18 housing, h = 5.2 mm, 2 pins isolated, 1 pin grounded	MEGA with attenuator up to 0.5 W/cm ²
D 0.50 mm ²	B = UVB $s_{\max} = 280 \text{ nm}$ $\lambda_{510\%} = 231 \text{ nm} \dots 309 \text{ nm}$	18S 2-pin TO18 housing, h = 3.7 mm, 1 pin isolated, 1 pin grounded	GIGA with attenuator up to 7 W/cm ²
L 1.00 mm ²	C = UVC $s_{\max} = 275 \text{ nm}$ $\lambda_{510\%} = 225 \text{ nm} \dots 287 \text{ nm}$	5 2-pin TO5 housing, h = 4.3 mm for broadband; h = 6.7 mm for filtered UVA, UVB, UVC, UVI	DIFFUSOR with anorganic diffusor for cosine correction
F 1.82 mm ²	E = UV-Index spectral response according to CIE087	18ISO90S 3-pin TO18 housing, h = 3.7 mm, 2 pins isolated, 1 pin grounded	
XL 7.60 mm ²		5ISO90 3-pin TO5 housing, h = 4.2 mm, 2 pins isolated, 1 pin grounded	

Further information

- use our interactive SiC UV photodiode finder: www.sglux.de/en/product-configurator
- call us +49 30 53015211 or send us an email: welcome@sglux.com
- study the background information shown at the following pages of this catalog

SiC UV Photodiodes

Catalog

TUTORIAL

to answer beginners and users questions about best use of SiC UV photodiodes

General information about the sglux SiC UV photodiodes

- About the material SiC **p. 1**
- sglux inhouse SiC wafer production since 2009 **p. 1**
- Photodiode amplification **p. 1**

Overview at the portfolio that ranges from 0.06 mm² until 36.00 mm² active area photodiodes with different housings, simple optics filtered for UVA, UVB, UVC or UV-Index spectral response **p. 2**

- Nomenclature **p. 2**

Tutorial to answer beginners and users questions about best use of SiC UV photodiodes

- 1.0 Selection of the chip active area (photocurrent limits) **p. 4**
 - 1.1 Problems with current too low **p. 5**
 - 1.2 Problems with current too high **p. 6**
 - 1.3 Calculation of the relation between UV radiation and photocurrent **p. 7**
- 2.0 Selection of the spectral response **p. 9**
 - 2.1 Unfiltered SiC **p. 10**
 - 2.2 Filtered SiC **p. 11**
- 3.0 Packaging features **p. 12**
 - 3.1 Overview **p. 12**
 - 3.2 Drawings **p. 13**
- 4.0 Special features **p. 15**
 - Appendix A Photodiode amplification notes **p. 15**
 - Upgrade to a TOCON or a PROBE **p. 16**

List of publications **p. 17**

1.0 Selection of the chip active area (photocurrent limits)

The chip active area determines how many photons can be collected by a photodetector. Semiconductor detectors, such as SiC UV photodiodes, convert photons into an electrical current, the *photocurrent* I . This photocurrent rises linearly with the irradiation power and the chip active area. sglux produces seven different area sizes:

$$A_1 = 0.06 \text{ mm}^2 \text{ (S-type)}$$

$$A_2 = 0.20 \text{ mm}^2 \text{ (M-type)}$$

$$A_3 = 0.50 \text{ mm}^2 \text{ (D-type)}$$

$$A_4 = 1.00 \text{ mm}^2 \text{ (L-type)}$$

$$A_5 = 1.82 \text{ mm}^2 \text{ (F-type)}$$

$$A_5 = 7.60 \text{ mm}^2 \text{ (XL-type)}$$

$$A_6 = 36 \text{ mm}^2 \text{ (XXL-type)}$$

As the detector price rises with increasing active area, the area selection basically is a compromise between costs and current.

If you know the minimum and maximum irradiance you like to measure with the UV photodiode the following simplified formula (1) shows a rough estimation of the photocurrent I given a particular chip active area A_{chip} .

$$I = A_{\text{chip}} * E_{\lambda} * 1.000 \quad (1)$$

where I is the photocurrent in nA, A_{chip} is the chip active area in mm^2 (enter values of 0.06 or 0.2 or 0.5 or 1 or 1.82, 7.6 or 36) and E_{λ} is the spectral irradiance of the UV light source you like to measure in $\text{mWcm}^{-2}\text{nm}^{-1}$. You may find more information about photocurrent calculation in chapter 1.3 (Calculation of the relation between UV radiation and photocurrent), p. 7.

If you do not know the irradiance coming from your UV light source chapter 1. section 1.3 gives some examples of common UV sources.

The minimum current (photodiode output at lowest irradiance to be measured) should not fall below 500pA. The maximum current must not exceed 400mA if the component's diode properties are to be maintained. Please refer to a detailed discussion on suitable minimum and maximum currents in the following chapters 1. section 1.1 (Problems with current too low) and 1. section 1.2 (Problems with current too high). These chapters assume a certain basic knowledge in photodiode amplifier circuits. If you are not familiar with circuits please see Appendix A (Photodiode Amplification Notes) at p. 15.

1.1 Problems with current too low

If the current is too low, one or more of the following problems ($P_1 - P_4$) may affect the measurement:

P_1 → The measurement signal comes too close to the UV photodiode dark current

P_2 → High resistance feedback resistors (R_f) must be used which causes temperature drift and non linearity problems

P_3 → Speed problems

P_4 → Risk of electromagnetic interferences

Using SiC, P_1 can be neglected due to the extremely low dark current of the sglux 4H SiC UV photodiodes of only some fA. P_2 (temperature drift and non linearity) becomes essential from values $R_f > 10 \text{ G}\Omega$. Therefore, the photocurrent I should be strong enough to allow R_f values of $\leq 10 \text{ G}\Omega$. The relation between I and R_f is given by Ohm's law:

$$I = U_{\text{supply}} / R_f \quad (2)$$

where U_{supply} is the supply voltage of the used transimpedance amplifier. A typical value is 5.00 V. Formula (2) calculates:

$$I_{\text{min}} = 5.00\text{V} / 10 \text{ G}\Omega = 500\text{pA} \quad (3)$$

If a higher speed measurement is needed P_3 (speed problems) could become an issue. As the SiC UV photodiode's detection speed is extremely high (in nanoseconds only) the amplifier speed (rise time) determines the circuit's speed. The amplifier rise time is calculated with the following formula:

$$\tau = R_f * C_f \quad (4)$$

where C_f is the feedback capacitor value which should not be lower than 0.1 nF. A lower C_f risks hitting the circuit's resonance. Using a $C_f = 0.1 \text{ nF}$ and a $R_f = 10 \text{ G}\Omega$ the rise time is calculated as follows:

$$\tau = 10 \text{ G}\Omega * 0.1 \text{ nF} = 1 \text{ second} \quad (5)$$

Formula (5) shows that using a $R_f = 10 \text{ G}\Omega$ the circuit becomes very slow. If a higher speed is needed the photocurrent I must be increased to allow a decrease in the R_f value. This can be done by increasing the UV radiation or, if that is not feasible, by increasing the chip active area.

The last problem (P_4) that can be caused with too low photocurrent (= due to too small an active area) is complications from electromagnetic interferences. This is a general issue. Decreasing photocurrents call for increasing shielding efforts which then increases the system price of the product. If the radiation (and thus the current) is low one should consider using a sglux TOCON amplified hybrid UV sensor.

Conclusion of needed minimum photocurrent I_{min}

To achieve a stable temperature and linear photodiode-amplifier system the lowest measurement current I_{min} should be higher than 500pA. If a high speed measuring circuit is needed I_{min} is calculated by the following formula:

$$I_{min} = U_{supply} * C_f * \tau^{-1} \quad (6)$$

With $U_{supply} = 5.00V$ (typical value), $C_f = 0.1nF$ (recommended value) and $R_f = 10 G\Omega$ (lowest recommended value) the formula reduces to:

$$I_{min} = 500 * \tau^{-1} \quad (7)$$

where I_{min} results in nanoamperes (nA) and τ must be in milliseconds.

In general, given these reasons, a decreasing photocurrent needs a more advanced amplifier design and better shielding. If you are not familiar with low current circuit development you should consider selecting a higher current (and thus larger active area) photodiode even if the price of a photodiode is higher. This strategy will provide conservative results and the initial increased financial cost will save you money in the long run.

1.2 Problems with current too high

In the previous pages we discussed the calculation of a minimum recommended photodiode current. It also should be mentioned that aside from the photocurrent being too low too high of a current may cause problems as well due to saturation effects. The saturation current I_{sat} of a photodiode is the current limit from which the output of a photodiode turns to arbitrary values. It is determined by the photodiode's open circuit voltage V_{oc} and its serial resistance R_s following the formula below:

$$I_{sat} = V_{oc} / R_s \quad (8)$$

A typical value (SiC photodiode) for V_{oc} is 2.0V and for $R_s = 5\Omega$. The calculation is as follows:

$$I_{sat} = 2.0 V / 5 \Omega = 400mA.$$

The needed minimum current (500 pA) is higher than the saturation current is higher by six orders of magnitude. Reaching the saturation limit of a SiC photodiode is therefore very unlikely.

1.3 Calculation of the relation between UV radiation and photocurrent

The photocurrent I is calculated by the following formula:

$$I = \int_{200\text{ nm}}^{400\text{ nm}} A_{\text{chip}} * S_{\text{chip}}(\lambda) * E_{\text{source}}(\lambda) d\lambda \quad (9)$$

where I is the photocurrent in A, A_{chip} is the chip active area in m^2 , S_{chip} is the chip's spectral sensitivity in A/W and E_{λ} is the spectral irradiance of the UV light source in $Wm^{-2}nm^{-1}$. Due to extreme visible and IR blindness (13 orders of magnitude) the integral value from 400nm to ∞ can be neglected even if $E_{\text{source}}(\lambda)$ is very strong. To get a rough estimate of the photocurrent generated by a certain irradiance a simplification of (9) leads to (10). That simplification assumes that the chip's spectral sensitivity S and the UV source's irradiance E is a constant value and does not depend on wavelength. The calculation is:

$$I = A_{\text{chip}} * S_{\text{chip}} * E_{\lambda} * 10.000 \quad (10)$$

where I is the photocurrent in nA, A_{chip} is the chip active area in mm^2 , S_{chip} is the chip's spectral sensitivity in $A/W \cdot nm^{-1}$ and E_{λ} is the spectral irradiance of the UV light source in $mWcm^{-2}nm^{-1}$.

A typical value of S_{chip} is 0.1 A/W. For further refinement please refer to the spectral response graph of the UV photodiode you are interested in (see Datasheet) or have a look at chapter 2.0 (Selection of the spectral response, p. 9) of this guide.

If you know the spectral irradiance range, (minimal and maximal values), of the UV light source and you would like to measure you can easily estimate the photocurrent I by using formula (10) and hence select a chip active area (S-, M-, D-, L-, F-, XL- or XXL-type) that guarantees that your minimum radiation generates a photocurrent of more than 500 pA. The following table lists some common UV applications / light sources with their spectral irradiances at peak. Please note that some simplifications apply; thus the table gives a rough estimation of photocurrents for the different UV source types and different chip active areas.

SiC UV Photodiodes

Catalog

	TYP. PEAK E_{λ}	S-TYPE I	M-TYPE I	D-TYPE I	L-TYPE I	F-TYPE I	XL-TYPE I
lacquer hardening Fe doped HG medium pressure lamp or LED	10 W/cm ²	600 μA	2 mA	5 mA	10 mA	18 mA	40 mA
UV sterilisation low or medium pressure HG lamp	10 mW/cm ²	600 nA	2 μA	5 μA	10 μA	18 μA	40 μA
Other sources various sources	10 μ W/cm ² – 1 mW/cm ²	0.6 – 40 nA	2 – 200 nA	5 – 500 nA	10 – 1000 nA	18 – 1800 nA	40 – 4000 nA
UV-Index sun	10 μ W/cm ²	600 pA	2 nA	5 nA	10 nA	18 nA	40 nA
Burner flame detection gas or oil flame	10 nW/cm ²	600 fA	2 pA 100 pA	5 pA 250 pA	10 pA 500 pA	18 pA 900 pA	40 pA
			with “LENS” feature or use a TOCON	with “LENS” feature or use a TOCON	with “LENS” feature or use a TOCON	with “LENS” feature or use a TOCON	

Comments:

• **Lacquer hardening**

S-chip is best. M, D, L, F, XL chips would work but are not needed.

• **UV sterilisation**

S-chip is best. M, D, L, F, XL chips would work but are not needed.

• **Other sources**

All chips are suited. Speed is the main consideration when selecting a chip being mindful of linearity and temperature dependence values. Please contact us for further refinement.



SiC UV Photodiodes

Catalog

- **UV-Index**

S-Chips are too small for this application. All other chips can be applied. The reliability increases with increasing chip active area. Due to very low current the use of a TOCON (amplified hybrid sensor) should be considered.

- **Burner flame detection**

All chips are too small for this type of detection. A burner flame can be detected with the photodiode „SGo1M-5Lens“ or “SGo1D-5Lens” or “SGo1L-5Lens” or “SGo1F-5Lens”. This sensor works with a concentrating lens. Alternatively the photodiode SGo1F-5ISO90 (1.82 mm² active area) can be applied. However, this photodiode needs an external concentrator lens. Please refer to chapter 4.0. (Special features), for more information. Another approach is to use a sglux TOCON_ABC1 sensor with its included amplifier. The TOCON_ABC1 converts 0-18 nW/cm² radiation into a 0-5 V output voltage.

2.0 Selection of the spectral response

This chapter assists in the selection of a spectral response profile best suited for the measurement. All sglux 4H SiC UV photodiodes provide an extreme visible/IR blindness of more than ten orders of magnitude. That means that the UV photodiodes reliably only measure the UV part of a radiation spectrum (and not the visible and/or infrared part), even if visible light or infrared radiation is strongly present. This is a unique feature of the semiconductor material SiC. Currently no other material provides that extreme visible blindness.

2.1 Unfiltered SiC

The following graph shows the spectral curve of an unfiltered 4H SiC UV photodiode.

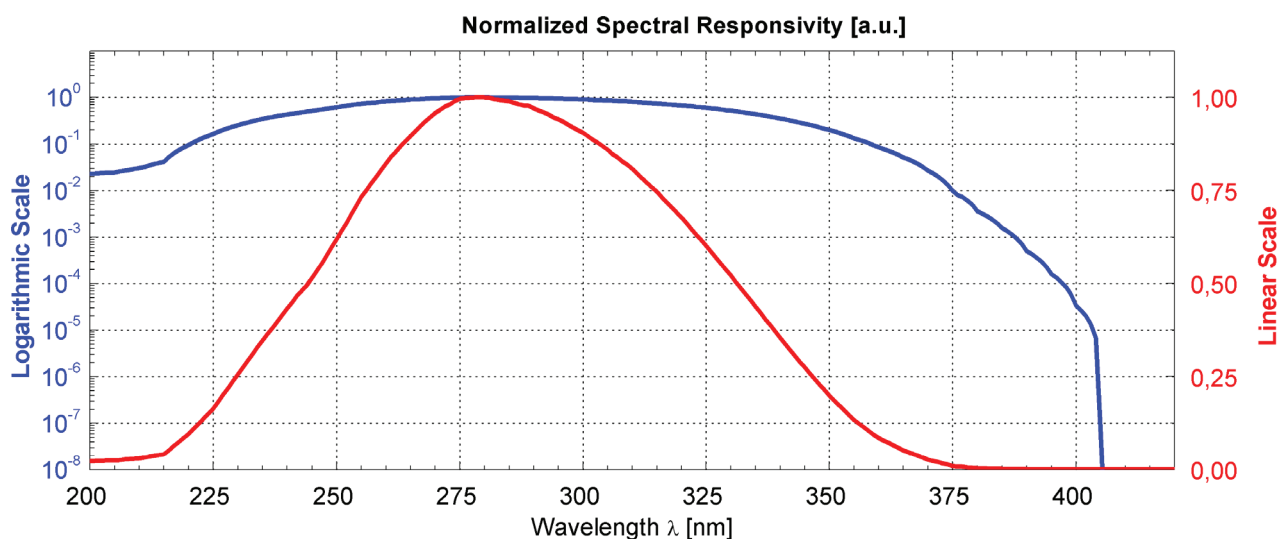

The curve's maximum is at approximately 280 nm. The response falls down to 10% of maximum at 221 nm, (UVC edge) and 358 nm, (UVA edge). Unfiltered SiC is the standard application and can be used for any UV measurements where the whole UV band needs to be measured or a quasi monochromatic UV source (such as low pressure lamps) is controlled.

2.2 Filtered SiC

Some applications require measurement of one particular part of the UV radiation spectrum, and it is essential that other UV radiation parts do not contribute to the photodiode's current. This requirement usually arises from standards as DVGW W294/2006 or CIE087 (UV-Index) etc. Other applications for filtered photodiodes are UVA-UVB-UVC selective sensor probes. sglux produces four different filtered SiC UV photodiode types.

- UVA (max = 331 nm)
- UVB (max = 280 nm)
- UVC (max = 275 nm)
- UV-Index (following CIE087 curve)

The following graph shows the four different spectra.

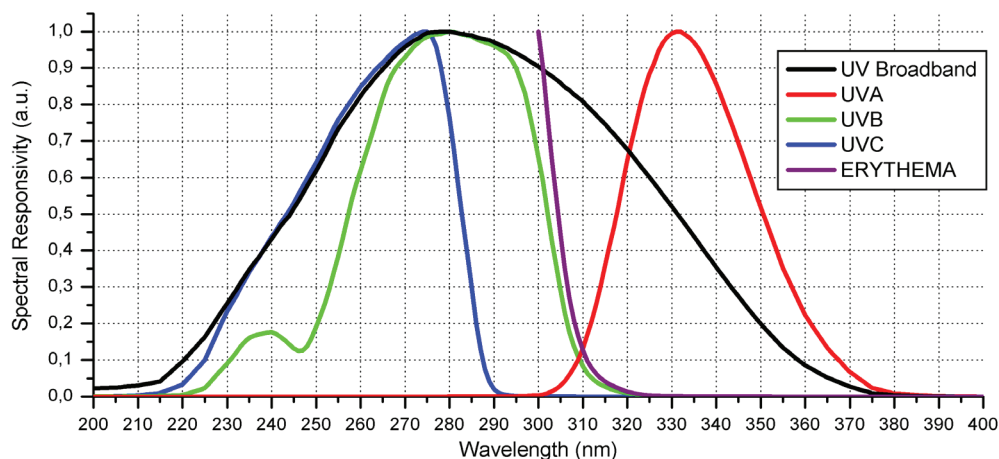

The graph assigns the filtered photodiode's spectral response to an individual wavelength. The following table extracts the most important specifications.

	WAVELENGTH of max.	SENSITIVITY at max.	WAVELENGTH 10% left side	WAVELENGTH 10% right side	VISIBLE BLINDNESS
no filter (broadband UV)	280 nm	0.130 A/W	221 nm	358 nm	>10 ⁻¹⁰
UVA	331 nm	0.037 A/W	309 nm	367 nm	>10 ⁻¹⁰
UVB	280 nm	0.125 A/W	231 nm	309 nm	>10 ⁻¹⁰
UVC	275 nm	0.120 A/W	225 nm	287 nm	>10 ⁻¹⁰
ERYTHEMA	280 nm	0.125 A/W	–	310 nm	>10 ⁻¹⁰

Other spectral specifications are available on request.

3.0 Packaging features

All sglux SiC UV photodiodes use a hermetically sealed melted window metal package. Each photodiode is gross and fine leak tested before sales. Two different sizes, (TO18 and TO5), with corresponding different heights and pin terminals are offered.

The reason for the different packaging types are technical in nature, (field of view, electrically floating housing, etc.) or just to allow the replacement of a previously applied photodiode by keeping the geometric parameters (footprint).

3.1 Overview

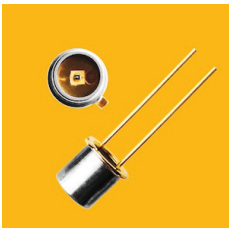
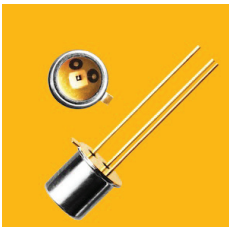
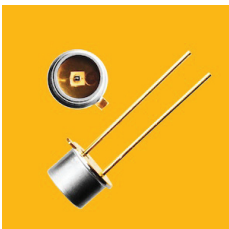
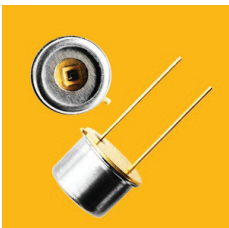
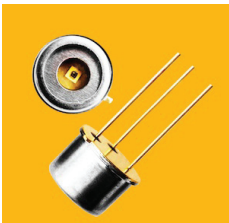
SAMPLE PICTURE	SELECTION CODE	DESCRIPTION
	18	TO18 Ni plated housing, 5.5 mm diameter, 5.2 mm height two gold plated pins (Anode grounded and Cathode isolated).
	18ISO90	TO18 Ni plated housing, 5.5 mm diameter, 5.2 mm height three gold plated pins (Anode and Cathode isolated, additional third pin for optional grounding of the body).
	18S	TO18 Ni plated short housing, 5.5 mm diameter, 3.7 mm height two gold plated pins (Anode grounded and Cathode isolated). Not available with filters.
	5	TO5 Ni plated housing, 9.2 mm diameter, 4.3 mm height (unfiltered photodiodes), 6.7 mm height (filtered photodiodes), two gold plated pins (Anode grounded and Cathode isolated).
	5ISO90	TO5 Ni plated housing, 9.2 mm diameter, 4.2 mm height (unfiltered photodiodes), 6.7 mm height (filtered photodiodes), three gold plated pins (Anode and Cathode isolated, additional third pin for optional grounding of the body).

SiC UV Photodiodes

Catalog

3.2 Drawings

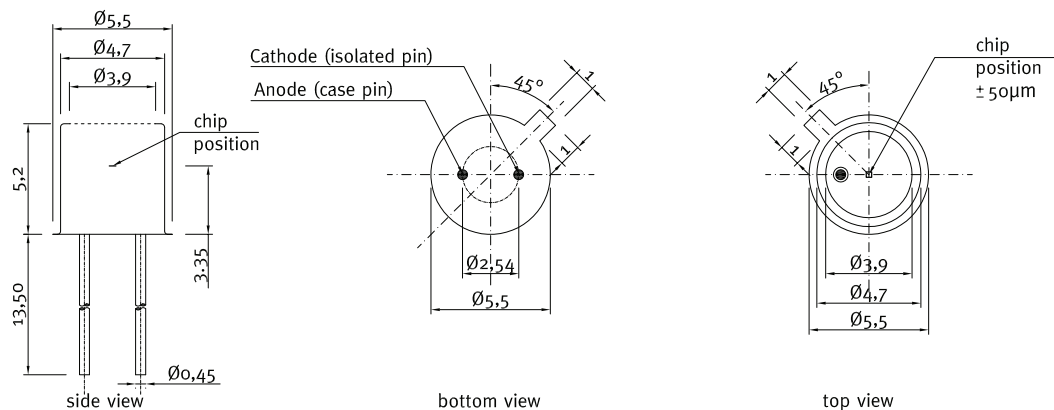

Selection code "18" \rightarrow TO18 Ni plated housing, 5.5 mm diameter, 5.2 mm height two gold plated pins (Anode grounded and Cathode isolated).

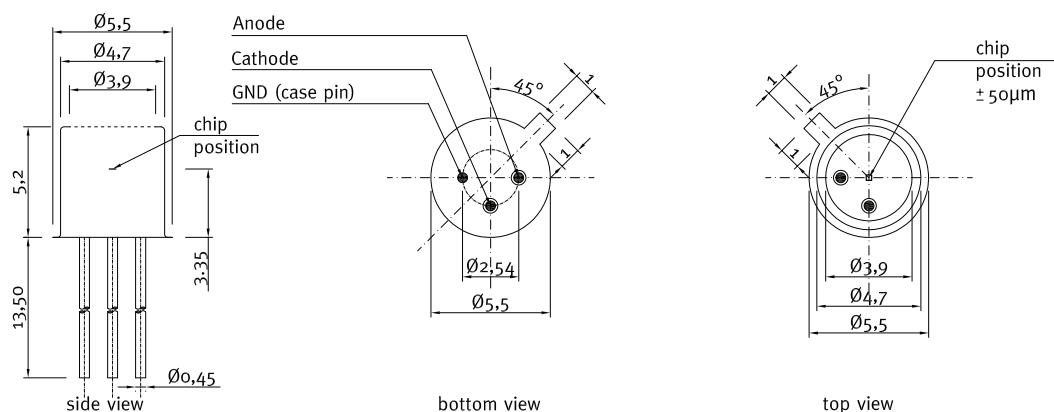

Selection code "18ISO90" \rightarrow TO18 Ni plated housing, 5.5 mm diameter, 5.2 mm height three gold plated pins (Anode and Cathode isolated, additional third pin for optional grounding of the body).

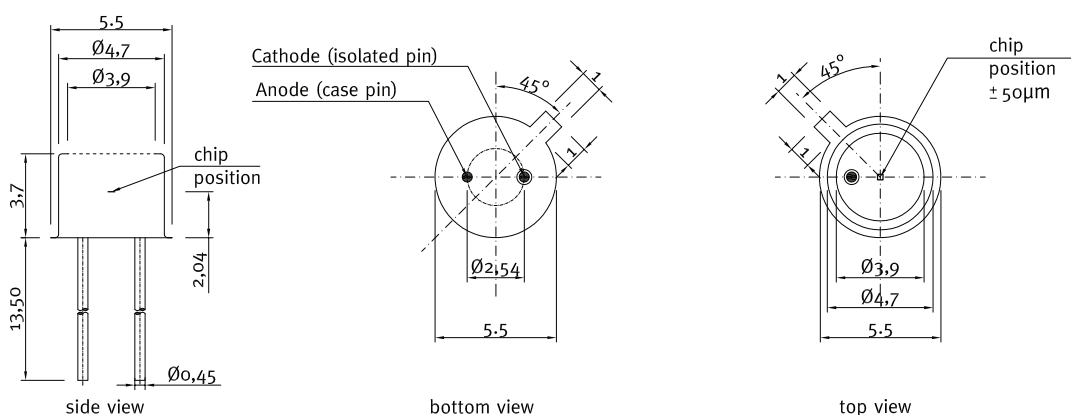

Selection code "18S" \rightarrow TO18 Ni plated short housing, 5.5 mm diameter, 3.7 mm height two gold plated pins (Anode grounded and Cathode isolated). Not available with filters.

SiC UV Photodiodes

Catalog

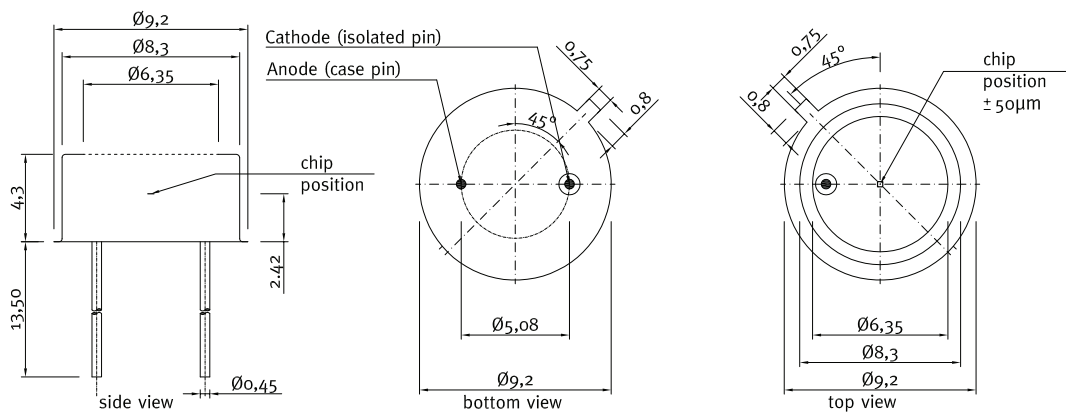

Selection Code "5" (photodiodes without filters) → TO5 Ni plated housing, 9.2 mm diameter, 4.3 mm height, two gold plated pins (Anode grounded and Cathode isolated).

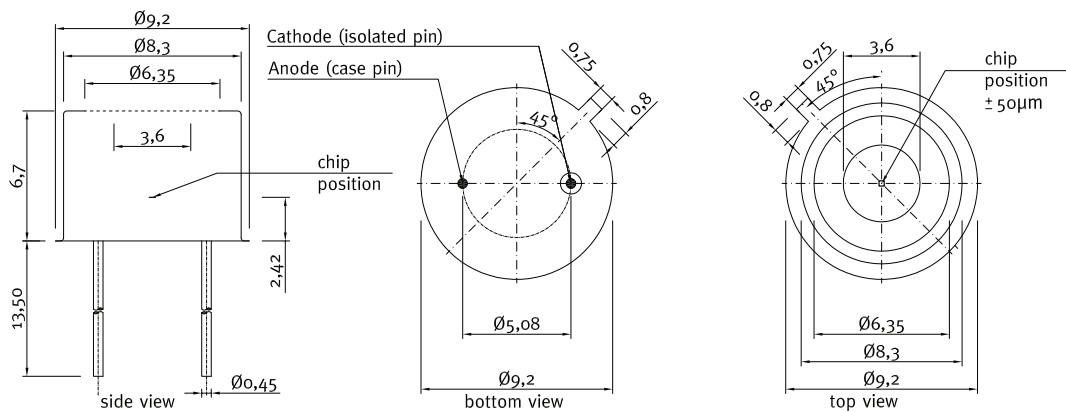

Selection Code "5" (photodiodes with filters) → TO5 Ni plated housing, 9.2 mm diameter, 6.7 mm height, two gold plated pins (Anode grounded and Cathode isolated).

4.0 Special features

Besides the three main selection criteria chip active area, spectral response and packaging details some special features can be added to the photodiode's properties. These special features are useful if the UV radiation is extremely high or low or if a cosine FOV is needed. The below table shows the selectable special features.

SELECTION CODE	DESCRIPTION
Lens	 Concentrating lens creating a virtual active area of 55 * real active area. This approximately multiplies the current by factor 55 while using the same chip active area. A disadvantage is a strongly reduced field of view compared with the flat window type.
MEGA	special attenuated photodiode for very strong UV radiation up to 0.5 W/cm ²
GIGA	special attenuated photodiode for extreme UV radiation up to 7 W/cm ²
DIFFUSOR	with anorganic diffusor for cosine correction

Appendix A – Photodiode amplification notes

For a correct reading of the photodiode the current (and not the voltage) must be analyzed. This requires a short circuiting of the photodiode. Usual approaches are using a Picoamperemeter e.g. produced by Keithley or a *transimpedance amplifier* circuit as shown below.

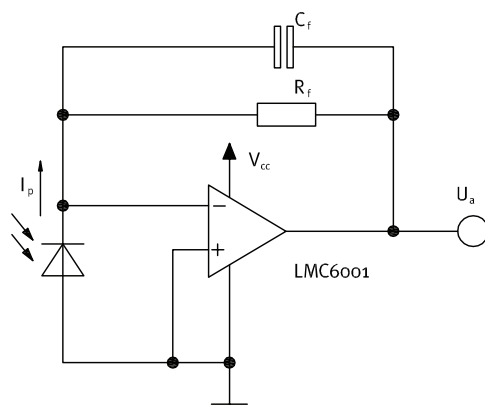

Calculations and Limits:

$$U_a = I_p \times R_f \approx 0 \dots \sim V_{cc}$$

$U_{a,max}$ depends on load and amplifier type

$$R_f = 10k\Omega \dots \sim 10G\Omega, C_f \geq 3pF$$

Recommendation: $R_f \times C_f \geq 10^{-3}s$

$$I_{p,max} = U_{a,max} \div R_f$$

$$\text{Bandwidth} = DC \dots \frac{1}{2\pi \times R_f \times C_f}$$

Example:

$$I_p = 20nA, R_f = 100M\Omega, C_f = 100 pF$$

$$U_a = 20 \times 10^{-9}A \times 100 \times 10^6\Omega = 2V$$

The adjacent design gives an example of a simple amplifier circuit. At the left side the photodiode is shown. The upper connection is the cathode (isolated pin of the photodiode) and the lower connection is the anode (usually grounded pin of the photodiode).

We recommend using a Texas Instruments LMC6001 transimpedance amplifier.

SiC UV Photodiodes

Catalog

Upgrade to a TOCON or a PROBE



TOCONs = UV sensors with integrated amplifier

- SiC based UV hybrid detector with amplifier (0-5V output), no additional amplifier needed, direct connection to controller, voltmeter, etc.
- Measures intensities from 1,8 pW/cm² up to 18 W/cm²
- UV broadband, UVA, UVB, UVC, Erythema measurements, blue and blue+VIS
- Different upgrades such as a M12x1 housing available



Miniature housing with M12x1 thread for the TOCON series

- Miniature housing with M12x1 thread for the TOCON series
- Optional feature for all TOCON detectors
- Robust stainless steel M12x1 thread body
- Integrated sensor connector (Binder 5-Pin plug) with 2m connector cable
- Easy to mount and connect



UV probes

- Different housings e.g. with cosine response, water pressure proof or sapphire windows
- Different electronic outputs configurable (voltage, current, USB, CAN, LAN)
- Good EMC safety

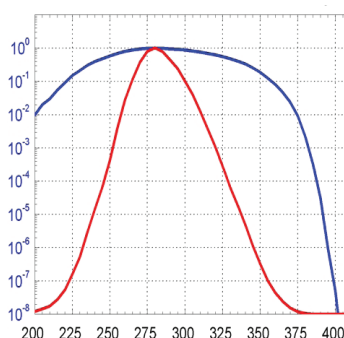

Calibration service

- Different NIST and PTB traceable calibrations and measurements for all sglux sensors
- Calibration of sensors for irradiation measurements
- Calibration of UV sensors on discrete wavelengths
- Determination of a specific spectral sensor responsivity

LIST OF PUBLICATIONS

P. Sperfeld¹, B. Barton¹, S. Pape¹, A. Towara¹, J. Eggers², G. Hopfenmueller³

¹Physikalisch-Technische Bundesanstalt Braunschweig und Berlin (PTB), Germany, ²DVGW-Technologiezentrum Wasser, Karlsruhe, Germany, ³sglux GmbH, Berlin, Germany

„Spectral irradiance measurement and actinic radiometer calibration for UV water disinfection“

Metrologia, Issue 51 (2014), p. 282-288.

P. Sperfeld¹, B. Barton¹, S. Pape¹, A. Towara¹, J. Eggers², G. Hopfenmueller³

¹Physikalisch-Technische Bundesanstalt Braunschweig und Berlin (PTB), Germany, ²DVGW-Technologiezentrum Wasser, Karlsruhe, Germany, ³sglux GmbH, Berlin, Germany

„Spectral Irradiance Measurement and Actinic Radiometer Calibration for UV Water Disinfection Proceedings of

NEWRAD 2014, edited by S. Park, P. Kaerhae and E. Ikonen. (Aalto University, Espoo, Finland 2014) p. 128.

B. Barton¹, P. Sperfeld¹, A. Towara¹, G. Hopfenmueller²

¹Physikalisch-Technische Bundesanstalt Braunschweig und Berlin (PTB), 4.1 Photometry and Applied Radiometry, Braunschweig, Germany, ²sglux GmbH, Berlin, Germany

„Developing and setting up a calibration facility for UV sensors at high irradiance rates EMEA Regional Conference, Karlsruhe, Germany (2013)

P. Sperfeld¹, B. Barton¹, S. Pape¹, G. Hopfenmueller²

¹Physikalisch-Technische Bundesanstalt Braunschweig und Berlin (PTB), 4.1 Photometry and Applied Radiometry, Braunschweig, Germany, ²sglux GmbH, Berlin, Germany

„Traceable spectral irradiance measurements at UV water disinfection facilities EMEA Regional Conference, Karlsruhe, Germany (2013)

G. Hopfenmueller¹, T. Weiss¹, B. Barton², P. Sperfeld², S. Nowy², S. Pape², D. Friedrich², S. Winter², A. Towara², A. Hoepe², S. Teichert²

¹sglux GmbH, Berlin, Germany, ²Physikalisch-Technische Bundesanstalt Braunschweig und Berlin (PTB), 4.1 Photometry and Applied Radiometry, Braunschweig, Germany

„PTB traceable calibrated reference UV radiometer for measurements at high irradiance medium pressure mercury discharge lamps EMEA Regional Conference, Karlsruhe, Germany (2013)

D. Prasai¹, W. John¹, L. Weixelbaum¹, O. Krueger¹, G. Wagner², P. Sperfeld³, S. Nowy³, D. Friedrich³, S. Winter³ and T. Weiss⁴

¹Ferdinand-Braun-Institut, Leibniz-Institut fuer Hoechstfrequenztechnik, Berlin, Germany, ²Leibniz-Institut fuer Kristallzuechtung, Berlin, Germany, ³Physikalisch-Technische Bundesanstalt Braunschweig und Berlin (PTB), 4.1 Photometry and Applied Radiometry, Braunschweig, Germany, ⁴sglux GmbH, Berlin, Germany

„Highly reliable silicon carbide photodiodes for visible-blind ultraviolet detector applications J. Mater. Res., first view (2012)

Copyright © Materials Research Society 2012. Personal use of this material is permitted. However, permission to reprint/republish this material for advertising or promotional purposes or for creating new collective works for resale or redistribution to servers or lists, or to reuse any copyrighted component of this work in other works must be obtained from the Cambridge University Press.

S. Nowy¹, B. Barton¹, S. Pape¹, P. Sperfeld¹, D. Friedrich¹, S. Winter¹, G. Hopfenmueller², and T. Weiss²

¹Physikalisch-Technische Bundesanstalt Braunschweig und Berlin (PTB), 4.1 Photometry and Applied Radiometry, Braunschweig, Germany, ²sglux GmbH, Berlin, Germany

„Characterization of SiC photodiodes for high irradiance UV radiometers Proceedings of NEWRAD 2011, edited by S. Park and E. Ikonen. (Aalto University, Espoo, Finland, 2011) p. 203.

B. Barton¹, P. Sperfeld¹, S. Nowy¹, A. Towara¹, A. Hoepe¹, S. Teichert¹, G. Hopfenmueller², M. Baer³, and T. Kreuzberger³

¹Physikalisch-Technische Bundesanstalt Braunschweig und Berlin (PTB), 4.1 Photometry and Applied Radiometry, Braunschweig, Germany, ²sglux GmbH, Berlin, Germany, ³SGIL Silicaglas GmbH, Langewiesen, Germany

„Characterization of new optical diffusers used in high irradiance UV radiometers Proceedings of NEWRAD 2011, edited by S. Park and E. Ikonen. (Aalto University, Espoo, Finland, 2011) p. 278.1.